

# Wireless Mini-Click<sup>®</sup> Sensor

OWNER'S MANUAL

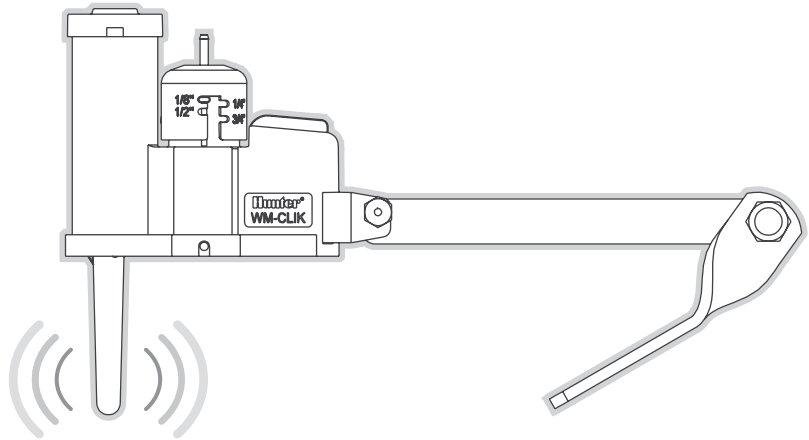

Wireless Mini-Click Sensor

For use with the Wireless Mini-Click Rain/Freeze Sensor

**Hunter<sup>®</sup>**

In most installations, the Wireless Mini-Clik Sensor acts as a switch that breaks the circuit to an irrigation system's solenoid valves in response to rain.

This allows the timer to advance as scheduled, but keeps the valves from opening the water flow. Once the Wireless Mini-Clik has dried sufficiently, the switch closes again to allow normal operation.

### Key Benefits

1. **Wireless Operation:** Up to 243 m line-of-sight. No wires are required between the rain sensor and controller.
2. **Optional Quick Response®:** Innovative technology that turns off the irrigation system immediately rather than after it has accumulated a fixed amount of rain. No calibration is required.
3. **Freeze Sensor:** Designed to keep the irrigation system from operating when temperatures drop to 3°C or below. When temperatures rise above this temperature, the sensor will enable automatic watering.
4. **Maintenance-Free Design:** Provides trouble-free operation for at least 5 years. There are no batteries to replace.
5. **Automatic Synchronization:** The Wireless Mini-Clik Transmitter will send wireless signals every hour to the receiver to ensure that the sensor and receiver are continuously synchronized.
6. **Lost Communication/Battery Status Indication:** The Sensor Bypass LED will flash if the receiver has not received a signal from the sensor. This can indicate a low or dead battery.

## Wireless Mini-Clik Sensor

1. **Manual Test Spindle:** Press and hold the manual test spindle to confirm proper operation of your sensor.
2. **Vent Cap and Spindle:** Used to adjust reset rate or dry out time for the sensor.
3. **Radio Antenna:** Transmits a wireless signal to the receiver up to 243 m line-of-sight. The antenna should be oriented vertically.
4. **Mounting Arm:** Metal extension arm for mounting the sensor.
5. **Battery Status LED:** Used to determine the status of the sealed battery. Pushing the manual test spindle will flash the LED light indicating that the battery is good.

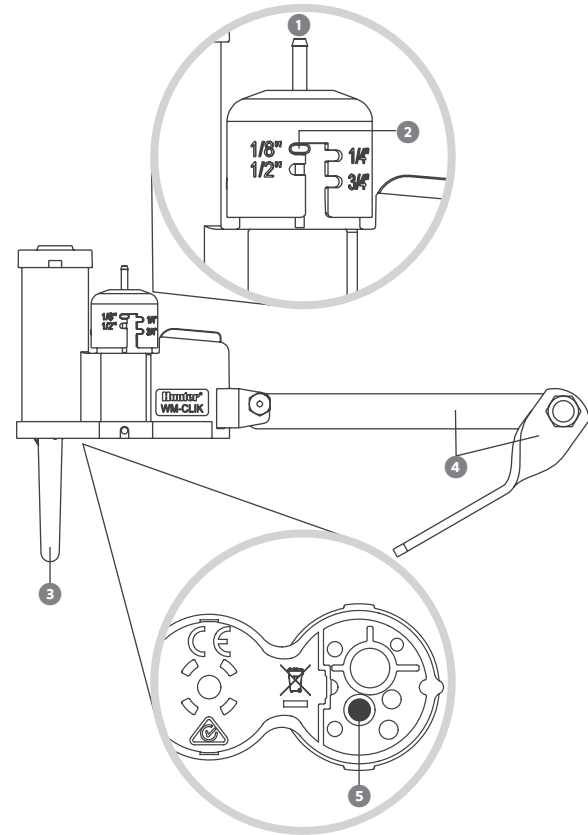

# Wireless Mini-Clik Components

## Wireless Receiver

1. **Bypass Button:** Allows automatic or manual watering when the sensor is active.
2. **Receiver Status LED:** Used to indicate the status of the sensor.
3. **Receiver Bypass LED:** Indicates when the sensor has been bypassed.
4. **Radio Antenna:** Receives a wireless signal from the transmitter up to 243 m line-of-sight. The antenna should be oriented vertically.
5. **AC Power Wires:** The two yellow wires are attached to a 24 VAC source from the controller.
6. **Receiver Wires:** The sensor wires are attached to either the sensor terminals in the controller or in-line with the valve common wire.
  - **Blue/White Wires:** Used for normally closed sensor applications (Hunter controllers).
  - **Blue/Orange Wires:** Used for normally open sensor applications.
7. **Rubber Cover:** Used to protect the receiver when mounted in outdoor locations.

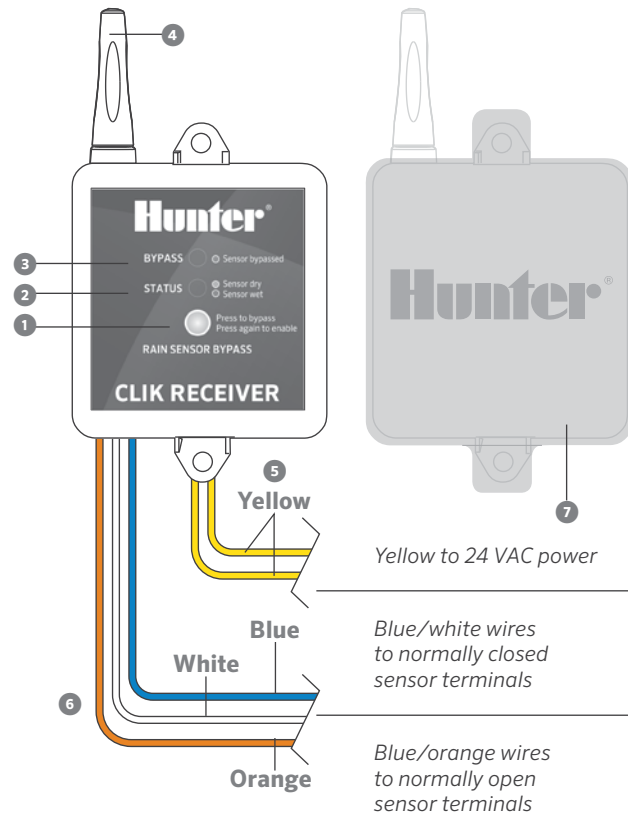

### Wiring the Receiver to Hunter Controllers

1. Remove the sensor jumper across the two SEN terminals in the controller.
2. Attach the two yellow wires to the 24 VAC terminals.
3. Attach the blue wire to one SEN terminal and the white wire to the other SEN or SEN COM terminal.



**Note:**

Additional setup steps required for Hydrawise®, ACC, and ACC2 Controllers.

- **Hydrawise Controllers:** Complete the installation by configuring the sensor in your Hydrawise account.
- **ACC Controllers:** Use features at the “Set Sensor Operation” dial position on ACC to complete setup.
- **ACC2 Controllers:** Use “Devices and Sensor Response” options on ACC2 to complete setup.



**SCAN**  
for help



[hunter.help/HydrawiseSensor](https://hunter.help/HydrawiseSensor)  
[hunter.help/ACC2Sensor](https://hunter.help/ACC2Sensor)

#### X2™ and X-Core®

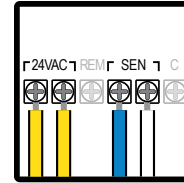

#### ACC2

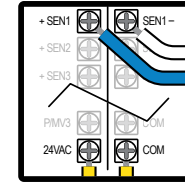

#### Pro-HC

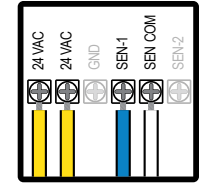

#### ICC2

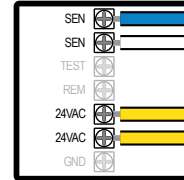

#### HCC

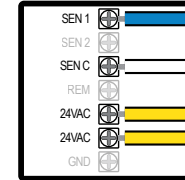

#### Pro-C® or HPC

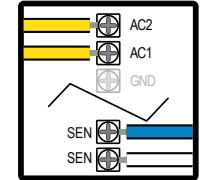

*Controllers manufactured before December 2022*

#### HPC

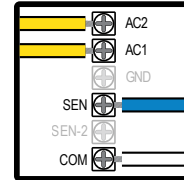

*Controllers manufactured after January 2023*

#### Pro-C

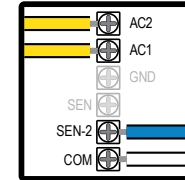

*Controllers manufactured after January 2023*



**Note:**

For the 2023 Pro-C model, connect one wire from the sensor to the SEN-2 screw terminal and the other sensor wire to the COM terminal.

## Wiring the Receiver to Other Controllers: Normally Closed Sensor Applications

1. Attach the two yellow wires to the 24 VAC terminals.
2. Attach the blue and white wires to the sensor terminals (if available) or in-line with the valve common wire.

## Wiring the Receiver to Other Controllers: Normally Open Sensor Applications

1. Attach the two yellow wires to the 24 VAC terminals.
2. Attach the blue and orange wires to the sensor input.

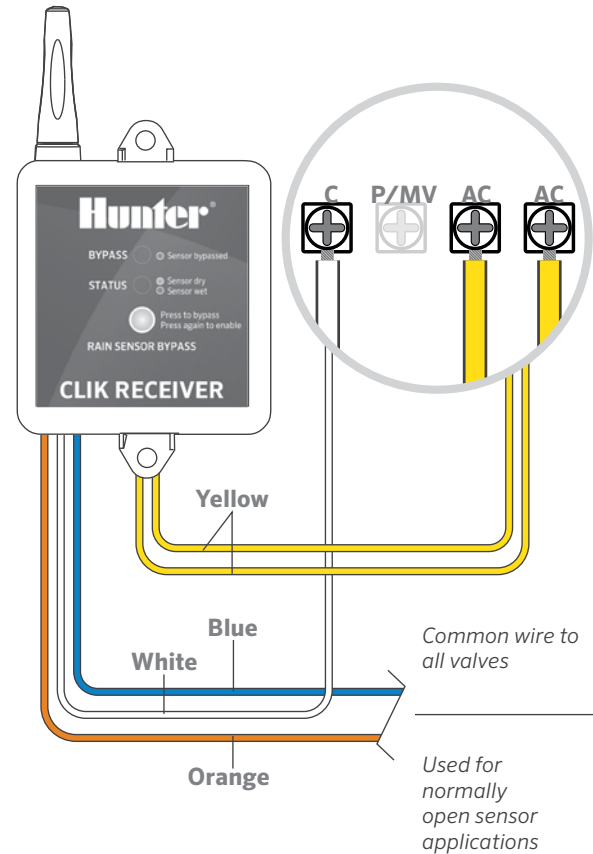

## Surface Mounting

Using the screws provided with your sensor, mount the transmitter on any surface where it will be exposed to unobstructed rainfall, but not in the path of sprinkler spray. The sensor should be oriented upright (as pictured), but the swivel bracket can be moved for mounting on any angled surface. Loosen the locknut and screw before swiveling the bracket, and then retighten.

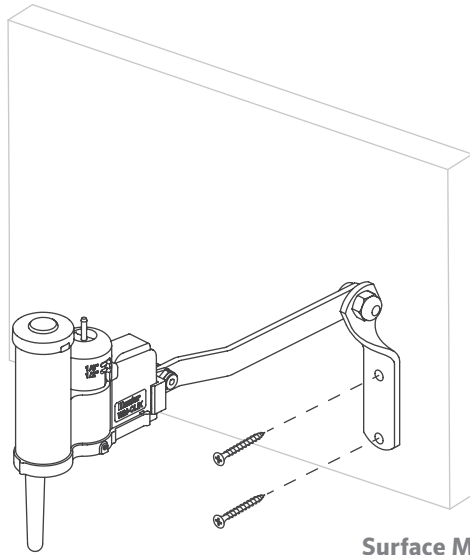

Surface Mount

## Gutter Mounting

The included Sensor Gutter Mount (SGM) bracket allows the transmitter to be mounted directly to the edge of a gutter. Install the SGM on the transmitter by removing the metal extension arm supplied with your sensor and reinstalling the SGM. Position the gutter mount on the edge of the gutter and twist the thumbscrew to secure it in place.

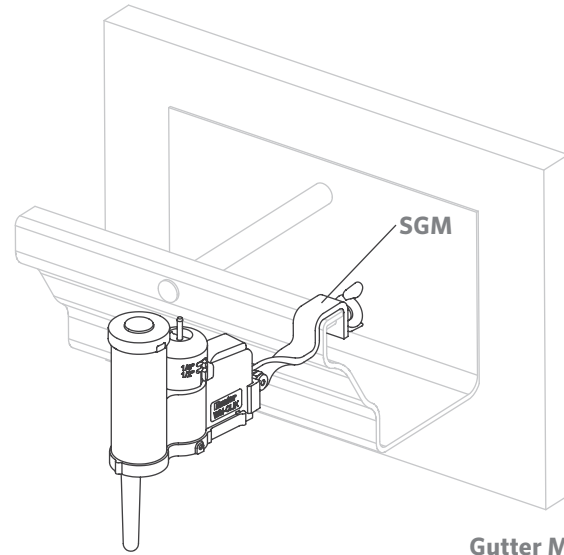

Gutter Mount

## Tips for Mounting the Sensor

- Choose a location such as the side of a building or post. The closer the transmitter is to the receiver, the better the reception. Do not exceed 243 m.
- To ensure maximum range in communication, mount the receiver and transmitter away from sources of electrical interference (e.g., control panels, transformers) or metal objects. Best performance occurs when no physical obstruction exists between the transmitter and receiver.
- Correct placement of the Wireless Mini-Clik Sensor is important for accurate temperature sensing. The best location would be out of direct sunlight.
- The reset rate refers to the amount of time it takes for the sensor to dry out before the sprinkler system will resume normal operation. The mounting location will affect this rate. For example, mounting the transmitter in a very sunny location may cause the sensor to dry out sooner than desired. Similarly, a sensor mounted in constant shade may take longer than expected to dry out.

## Receiver Operation

The receiver has two LED lights that indicate the state of the system.

### • **SENSOR STATUS LED:**

**RED:** Sensor is wet (watering disabled)

**GREEN:** Sensor is dry (watering enabled)

**YELLOW:** Sensor is in addressing mode

### • **SENSOR BYPASS LED:**

**RED:** Rain sensor is bypassed (Note: the STATUS LED will continue to alert you of the state of the sensor — wet or dry)

**GREEN:** Rain sensor is enabled

**YELLOW:** Indicates that communication between the transmitter and receiver was lost



### **Note:**

When you first apply power to the receiver, the **SENSOR STATUS LED** will be **RED**. Press the manual test spindle on the transmitter for five seconds and release the spindle. The **SENSOR STATUS LED** will turn **GREEN**, indicating proper operation.

---



## Transmitter Operation

The Wireless Mini-Clik Sensor keeps the irrigation system from starting or continuing after receiving rainfall quantities of 3 mm, 8 mm, 13 mm, and 19 mm. To adjust it to the desired shutoff quantity, rotate the cap on the switch housing so that the pins are located in the proper slots. Do not forcibly twist the cap as this could break the pins.

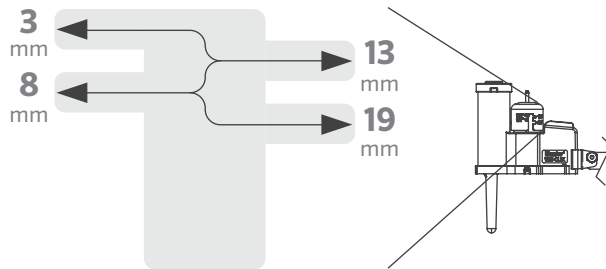

The time that it takes the Mini-Clik Sensor to reset for normal sprinkler operation after the rain has stopped is dictated by weather conditions (e.g., wind, sunlight, humidity). These conditions will determine how fast the hydroscopic discs dry out. Since the turf will experience the same conditions as the discs, their respective drying rates will roughly parallel each other. This means that, when the turf needs more water, the Mini-Clik should have already reset itself to allow the sprinkler system to run at the next schedule cycle.



### Note:

Once the desired rainfall quantity has been set, it's recommended that the settings remain the same for the entire lifespan of the sensor since the hydroscopic discs become accustomed to the first setting chosen after the first rainfall event. It's unlikely that the hydroscopic discs will respond to a new setting, which may prevent irrigation from shutting down when expected.

## Optional Quick Response Feature

To use Quick Response, a feature that immediately turns the system off as soon as rain begins, open the rubber cover to allow rain to hit the Quick Response discs. This setting will override the adjusted rainfall settings.

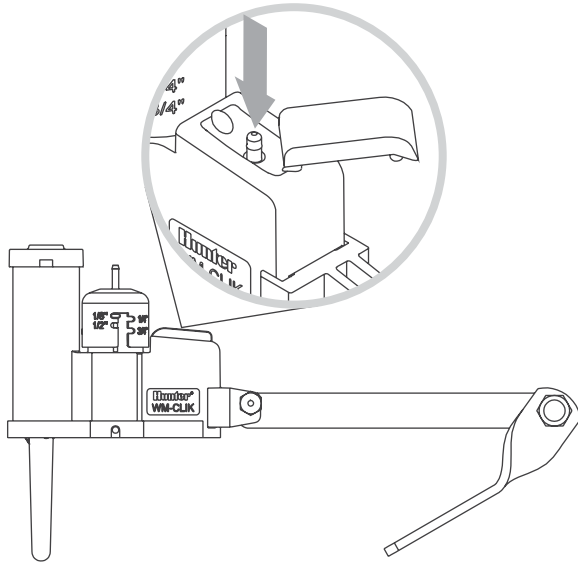

## Bypassing the Sensor

The sensor can be bypassed by using the built-in bypass feature on the receiver. To bypass the sensor, press the **SENSOR BYPASS** button on the receiver. The bypass status light will turn red when the sensor is bypassed. Pressing the **SENSOR BYPASS** button again will re-enable the sensor, and the sensor bypass light will go out.

## Setting the Transmitter Address at the Receiver

Each transmitter is manufactured with a unique address. A receiver must learn this address to work with that transmitter. These steps are only necessary if transmitters and receivers are purchased separately or communication needs to be reestablished.

1. Prior to supplying power (yellow wires) to the receiver, press and hold the bypass button on the receiver.
2. While the bypass button is depressed, supply power to the receiver. The yellow sensor status indicator should light up, indicating that the receiver is ready to learn a new address.
3. Press and hold the quick response button on the transmitter.
4. Within four seconds, the receiver's sensor status indicator light should turn red. The receiver has now learned the address and will retain it, even in the event of a power outage.
5. Release the button on the transmitter. The sensor status indicator light should turn green.

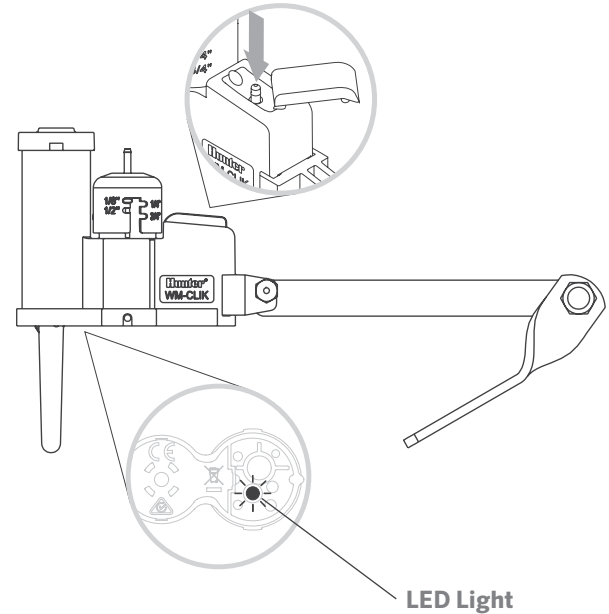

### Note:

Units purchased as a kit will already have their communication address preset. No addressing is necessary. However, if the receiver or transmitter is replaced, you'll need to reset the address.

### Battery Life

The Wireless Mini-Clik Sensor is designed to operate for at least 5 years with its sealed, maintenance-free battery. The sensor is available as a replacement part (WMCLIK-TR). Should you need to change the sensor, the receiver must learn the new sensor address.

### To Check the Status of the Battery in the Sensor

1. Press and hold the Quick Response spindle at the top of the sensor.
2. Within a few seconds the LED light on the bottom of the sensor will briefly flash.
3. Release the spindle and the LED light will flash again. If the LED flashes, the battery in the sensor is good.



[hunter.help/miniclik](http://hunter.help/miniclik)

If you're experiencing problems with your Wireless Mini-Clik Sensor, follow these simple checks first before assuming the unit is defective and replacing it.

### System Will Not Turn On at All

- Check to make sure the sensor discs are dry and the switch “clicks” on and off freely by pressing the top of the spindle.
- Look for breaks in the wire leading to the receiver and check all connections.
- Verify that the outside air temperature is above 3°C.

### System Will Not Shut Off Even After Heavy Rainfall

- Remove the sensor jumper across the two SEN terminals. Check to make sure that rain is hitting the sensor.
- Look for breaks in the wire leading to the receiver and check all connections.
- Check the battery status in the sensor.

### Sensor Bypass LED Is Flashing Red

- Check that the battery in the sensor is good.
- Check for obstructions around the sensor or receiver antenna.
- Reset communication address between the transmitter and receiver (see page 11).

## REPLACEMENT PARTS

Part Number	Description
WM-CLIK-TR	Wireless Mini-Clik transmitter only
10023600SP	Wireless Mini-Clik cap with spindle assembly
10023900SP	Wireless Mini-Clik quick shutoff cover
439700	Mounting bracket
SGM	Sensor Gutter Mount
WM-CLIK-R	Receiver assembly
231300SP	Receiver rubber cover



[hunter.info/FindADealer](http://hunter.info/FindADealer)

## USER-INSTALLED OPTIONS

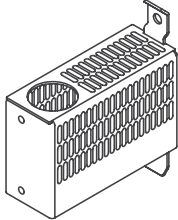
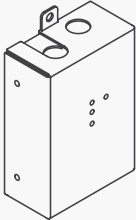
Part Number	Description
WS-GUARD	 <p>Vandal-resistant wireless sensor guard for flat surfaces or pole mounting (order sensor separately)</p>
WR-GUARD	 <p>Vandal-resistant wireless receiver guard for pedestal mounting (order receiver separately)</p>

## FCC Notice

This device complies with part 15 of the FCC Rules. Operation is subject to the following two conditions: (1) This device may not cause harmful interference, and (2) this device must accept any interference received, including interference that may cause undesired operation.

This equipment has been tested and found to comply with the limits for a Class B digital device pursuant to Part 15 of the FCC Rules. These limits are designed to provide reasonable protection against harmful interference in a residential installation. This equipment generates, uses, and can radiate radio frequency energy and, if not installed and used in accordance with the instructions, may cause harmful interference to radio communications. However, there is no guarantee that interference will not occur in a particular installation. If this equipment does cause harmful interference to radio or television reception, which can be determined by

turning the equipment off and on, you are encouraged to try to correct the interference by taking one or more of the following measures:

- Reorient or relocate the receiving antenna.
- Increase the separation between the equipment and receiver.
- Connect the equipment into an outlet on a circuit different from that of which the receiver is connected.
- Consult the dealer or an experienced radio/TV technician for help.

Changes or modifications not expressly approved by Hunter Industries could void the user's authority to operate this device. If necessary, consult a representative of Hunter Industries Inc. or an experienced radio/television technician for additional suggestions.

## Innovation, Science and Economic Development Canada (ISED) Compliance Notice

This device contains licence-exempt transmitter(s)/ receiver(s) that comply with Innovation, Science and Economic Development Canada’s licence-exempt RSS(s). Operation is subject to the following two conditions:

1. This device may not cause interference.
2. This device must accept any interference, including interference that may cause undesired operation of the device.

Le présent appareil est conforme aux CNR d’Industrie Canada applicables aux appareils radio exempts de licence. L’exploitation est autorisée aux deux conditions suivantes:

1. L’appareil ne doit pas produire de brouillage, et
2. L’utilisateur de l’appareil doit accepter tout brouillage radioélectrique subi, même si le brouillage est susceptible d’en compromettre le fonctionnement.

### MAXIMUM OUTPUT POWER

Frequency Band (MHz)	Maximum Output Power (dBm)
433.050 - 434.790	-6.20

## CE

Hereby, Hunter Industries declares that the radio equipment type models WM-CLIK-TR are in compliance with Directive 2014/53/EU.

The full text of the EU declaration of conformity is available at the following internet address:

<http://subsite.hunterindustries.com/compliance>



[hunter.info/compliance](http://hunter.info/compliance)

---

Helping our customers succeed is what drives us. While our passion for innovation and engineering is built into everything we do, it is our commitment to exceptional support that we hope will keep you in the Hunter family of customers for years to come.



Gregory R. Hunter, CEO of Hunter Industries



Denise Mullikin, President, Landscape Irrigation and Outdoor Lighting

---

**HUNTER INDUSTRIES** | *Built on Innovation*®  
1940 Diamond Street, San Marcos, CA 92078 USA  
hunterindustries.com