

ACC2 DECODER CONTROLLER

Design Guide

Intelligent, flexible, and powerful control
for the largest landscapes

Hunter[®]



ACC2 DECODER CONTROLLER DESIGN GUIDE

Table of Contents

Overview.....	4
Benefits.....	5
Wire Specifications and Rules.....	6
Earth Grounding.....	8
Decoder-to-Solenoid Wiring.....	9
Decoder Outputs, Power Factors, and Inrush.....	9
Decoder Hardware and Models.....	10
ACC2 Decoder Installation Specifications.....	14
Cable Design Formulas.....	15
Cables from Decoder to Solenoid(s).....	17
Multiple Solenoids from One Decoder Output.....	17
Power Factor.....	17
Surge Protection.....	18
Earth Grounding Hunter Decoder Systems.....	19
Notes.....	23



hunter.info/ACC2decoder

ACC2 DECODER CONTROLLER DESIGN GUIDE

Overview

Control large irrigation systems over long distances using two-wire decoder technology available with the ACC2 Controller. Follow the steps below for proper installation.

1. Insert waterproof decoder modules as needed in a low voltage, direct burial, two-wire path.
2. Cut the wire wherever station control is needed, and splice the decoder wires into the path.
3. Connect the decoders to local standard 24 VAC solenoids for individual operation of valves and similar devices.

The signal for unique decoder addresses and the power for solenoid operation are sent over the single pair of wires, which can individually operate up to 225 decoders.

ACC2 DECODER MODELS

Model	Description
A2C-75D-M	75-station base model, gray metal outdoor, wall mount
A2C-75D-P	75-station base model, plastic outdoor, wall mount
A2C-75D-SS	75-station base model, stainless steel, wall mount
A2C-75D-PP	75-station base model, plastic pedestal

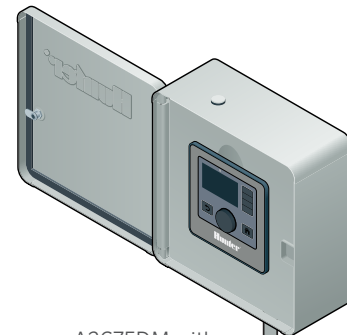

A2C75DM with two-wire decoder technology, up to 225 stations

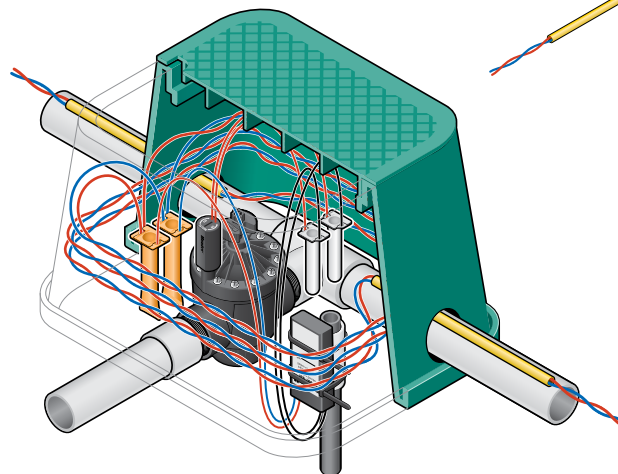

Decoder in valve box

ACC2 DECODER CONTROLLER DESIGN GUIDE

Benefits

Hunter's ACC2 Decoder Systems offer numerous benefits that save time, money, and labor over their lifespan.

- **Decoder systems save wire.** The greatest attraction for many users is the ability to operate up to 225 stations with only two wires (usually 14 AWG (2.08 mm²) solid copper), instead of 100+ wires. You can also save connectors and labor associated with large numbers of individual wire runs.
- **Decoder systems are flexible.** As long as the two-wire path is reasonably accessible, you can add stations to an irrigation system later with minimal disruption to the turf and landscape. Just insert additional decoders into the path at any point. To minimize wasted wire, you can even splice and tee decoder wire runs to follow pipe trenches.
- **Decoder systems offer electrical efficiencies.** They can operate large numbers of solenoids over long distances.
 - With 14 AWG (2.08 mm²) solid wire, a controller can activate solenoids up to 10,000' (3 km) away.

Note

The metric diameter is based on commonly available wire sizes in international markets. IDWIRE1 is technically 1.63 mm (2.08 mm²) diameter.

- With 12 AWG (4 mm²) diameter wire, decoder systems can operate up to 15,000' (4.5 km) away. Longer runs are possible with even heavier wire, but this is not necessarily practical.
- The ACC2 Decoder Controller family provides up to three two-wire paths per module. However, the ACC2 station mapping feature allows assignment of additional output module stations to other modules, so there's no practical limit (up to 225) on the number of stations that can be placed on a two-wire path.

- **Decoder systems are lightning resistant.** While no irrigation system is immune to lightning, decoder systems offer protection because they have less wire in the ground. When properly installed, they provide excellent grounding and surge suppression, making them popular in regions with high lightning exposure.
- **Decoder systems are rather easy to troubleshoot.** With just two wires per path, identifying system issues is relatively simple. You can get additional aid from the decoder menu that appears in any ACC2 Decoder Controller user interface.

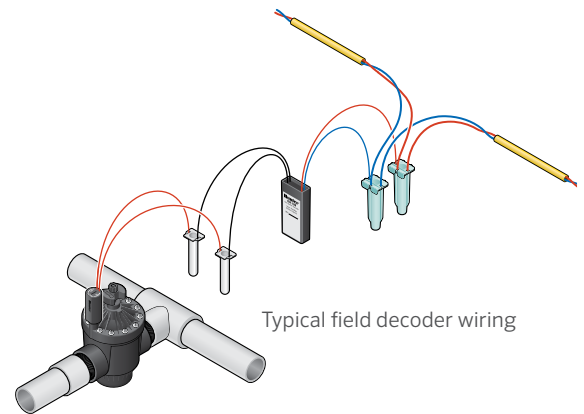

ACC2 DECODER CONTROLLER DESIGN GUIDE

Wire Specifications and Rules

Wire and wire installation is a key factor in successful decoder installations. Be aware that substituting wire or wire splices may cause major start-up service troubles.

For ACC2 Decoder Controller Systems, we recommend using color-coded wire selections with outer jackets for additional protection of decoder wire.

Twisted pairs are not shielded or armored, but the outer jacket protects them from abrasion and sunlight damage.

Model	Description	Specification
ID1GRY	Gray outer jacket	14 AWG (2.08 mm ²) solid-core twisted pair, 2,500' (760 m) per standard spool; use up to 10,000' (3 km)
ID1PUR	Purple outer jacket	
ID1YLW	Yellow outer jacket	
ID1ORG	Orange outer jacket	
ID1BLU	Blue outer jacket	
ID1TAN	Tan outer jacket	12 AWG (3.3 mm ²) solid-core twisted pair, 2,500' (760 m) per standard spool; use up to 15,000' (4.5 km)
ID2GRY	Gray outer jacket	
ID2PUR	Purple outer jacket	
ID2YLW	Yellow outer jacket	
ID2ORG	Orange outer jacket	
ID2BLU	Blue outer jacket	
ID2TAN	Tan outer jacket	



ID1TAN Wire, Twisted Pair

Since the two-wire path is low voltage, conduit is not necessary unless local regulations require it. Shielding, steel armor, and conduit will not inhibit performance and are permissible when desired.

Paths

Each two-wire output run of wire is called a "path."

- The ACC2 Decoder Controller provides up to nine path outputs to the field (three per output module). Decoders may be installed on some or all of them in any combination. Color-coded external jackets allow for easy path identification in the field.
- It's not necessary to connect the paths to one another. Each path runs from the controller to the previous decoder. Generally, looping a two-wire path from one output to another (back to the controller) is not

recommended. It provides little benefit and complicates troubleshooting.

- Never connect a wire path from one controller to the wire paths from another controller as this will cause damage to the output modules.

Twisted wire is required on all paths. The twist in the wire is an essential part of surge suppression. It minimizes the difference in potential during a surge and adds inductance. Since lightning damage is never covered by warranty, using twisted wire that meets all the previously mentioned specifications can prevent a costly repair.

Color coding is mandatory. The red and blue coding is a convenience for matching the wires to Hunter decoders. External color-coded jackets aid in diagnostics after initial installation and protect wires from shorts to earth.

Using preexisting wire: This is discouraged by Hunter for the following reasons:

- It's unlikely that preexisting wire meets the specifications for gauge, twist, and solid copper.
- Preexisting wire will not be color-coded correctly for the decoder wires.
- Preexisting wire may have invisible problems, such as shorts, breaks, increased resistance, or damaged insulation that may impact the new installation and lead to costly repairs.

Wire Connectors

All connections and splices in the red and blue two-wire path (IDWIRE) must be made with waterproof DBRY-6 or equivalent connectors.

- All Hunter decoders come with DBRY-6 connectors.
- All "-6" connectors are rated to 600 V direct burial and feature high temperature resistance.
- Additional splices and connections in the two-wire path must be made with equivalent connectors.

When a splice or connection is made, it's important to leave adequate slack in the wires. Leave 5' (1.5 m) slack to keep wire contraction from damaging connections and allow splice removal from the valve box for service or inspection.

Wire slack may be coiled neatly or around the inside of the valve box.

ACC2 DECODER CONTROLLER DESIGN GUIDE

Wire Specifications and Rules (continued)

Decoder-to-solenoid connections may be made with standard waterproof DBY or equivalent connectors. These require only 30 V or similar ratings but still require slack and strain relief.

- It's permissible to T-splice decoder wire paths.
- All T-splices must be made in valve boxes with DBRY-6 or equal connectors.
- T-splices require making a three-way connection in both the red and blue wires.
- It's especially important to allow adequate slack in a three-way splice. You should be able to withdraw each splice from the valve box for above-ground inspection and service.

Where possible, run the two-wire paths in the same trenches as irrigation pipe to gain some wire protection. This is a logical approach because the pipe leads to the valves where decoders will be positioned (see illustration).

The maximum run of a given wire type is valid from the controller to the end of each arm of the T.

If the total distance from the controller to the end of each arm of the T is under 10,000' (3 km), the system meets specification, even if the total amount of wire exceeds 10,000' (3 km).

For example, consider a scenario where 14 AWG (2.08 mm²) ID1 wires are being used. If a T is placed 5,000' (1.5 km) from the controller, and two arms each run an additional 5,000' (1.5 km) in different directions, the wire is within specifications. That's because it's only 10,000' (3 km) to the end of each arm of the T from the controller, even though there is 15,000' (4.5 km) total wire connected to the output.

It's possible to have more than one splice in a wire run, provided all the above conditions are met.

In very large systems, the length of the wire run and the number of intervening devices (other decoders) may affect the ability to run simultaneous stations near the end of the wire run. This will not damage the equipment but may require adjusting station timing to prevent underpowering the solenoid outputs. The calculations near the end of this document help determine if there is adequate power for any given wiring scenario.

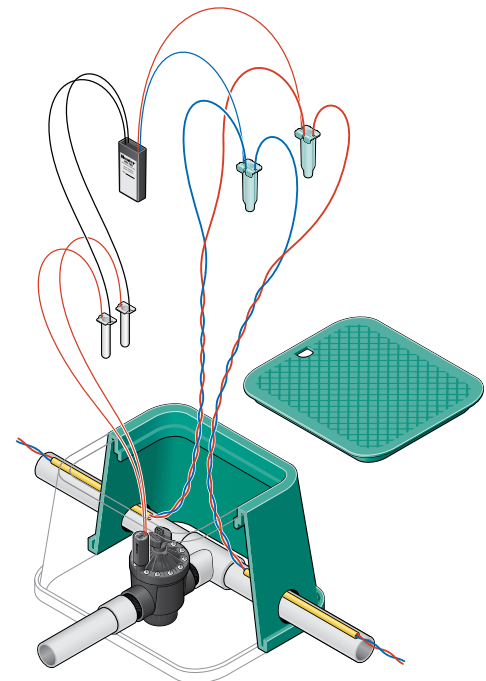
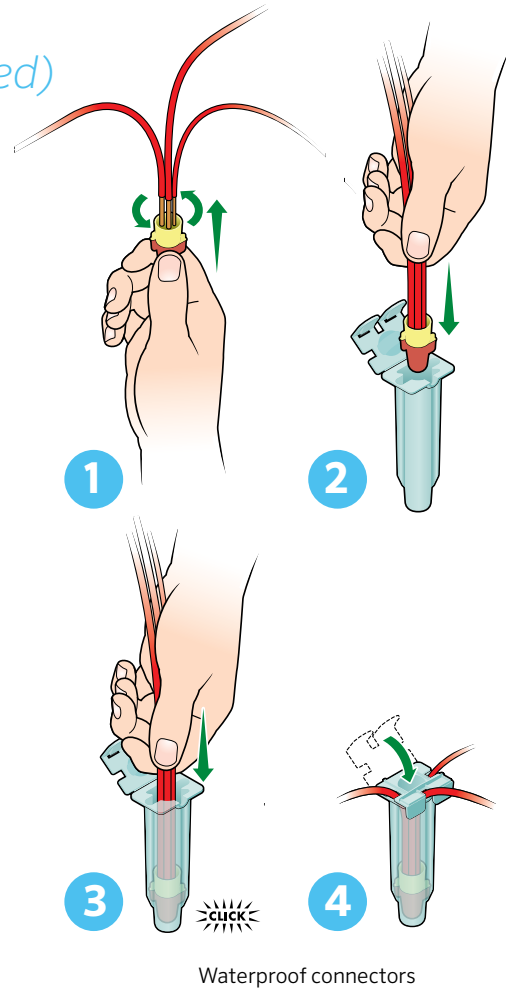

ACC2 DECODER CONTROLLER DESIGN GUIDE

Earth Grounding

Earth grounding of decoder systems is another part of installation that requires planning and careful installation. Properly grounded decoder systems perform very well, even in regions with frequent lightning storms. Poor grounding often results in unnecessary equipment losses and irrigation downtime.

Earth grounding rules for ACC2 Decoder Controllers are the same as for previous ACC/ICD Controllers. When retrofitting a new ACC2 Decoder Controller to an older ICD installation, there's no need to change grounding or field wiring if it was to specification originally. A large ground lug, or clamp, is provided in the controller for connecting bare copper wire to earth grounding hardware.

! Note

When feasible, install the grounding wire and earth ground hardware at right angles from two-wire paths to locate any possible discharge as far away as possible.

Decoder installations also require earth grounding in the two-wire path itself to protect the decoder investment. Hunter ICD Decoders feature integrated surge suppression, and each is equipped with a bare copper wire for connecting to earth ground hardware.

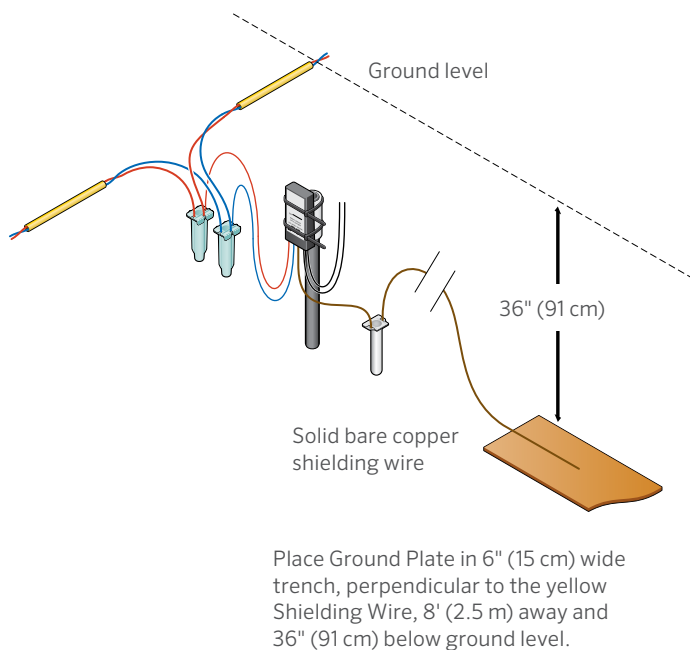

Earth ground should be connected at every 12th decoder, or 1,000' (330 m) of wire run, whichever is shorter. The station size of the decoders is not taken into account for grounding purposes. Every 12th decoder module is the minimum rule.

The final decoder in any wire run should be grounded. This includes the final decoders in each of the different arms of a T if the arm is more than 500' (150 m).

Place a ground plate in a 6" (15 cm) wide trench, perpendicular to the yellow shielding wire, 8' (2.5 m) away and 36" (1 m) below ground level.

The ground wires on intervening ICD Decoders are not used. It's not necessary to remove the unused ground wire or bury it. Simply fold it out of the way. This allows additional grounding in the future or use of the decoder in another location.

The use of separate bonding wire in the trench between all grounded decoder points is not required. However, it can dissipate surge energy and help prevent pipe damage in the event of a lightning strike.

Decoder Staking

Using a sturdy stake to keep decoders and their connections off the ground and out of mud and debris is a best practice that provides extended system life, simple serviceability, and easy maintenance. While installers sometimes make their own versions with PVC pipe or other materials, Hunter offers the Universal Decoder Stake (DECSTAKE10) for this purpose. Designed for installation in the valve box, this economical accessory comes with zip ties to easily secure decoder bodies. This keeps the decoder and its connectors clear and accessible after initial installation. ICD Decoders should be mounted upside down with the wires pointed down toward the ground. Positioning the bottom of the decoder upward sets it up for later use with the handheld ICD-HP Programmer. Made from recycled materials, the Universal Decoder Stake is sold in a convenient 10-pack.

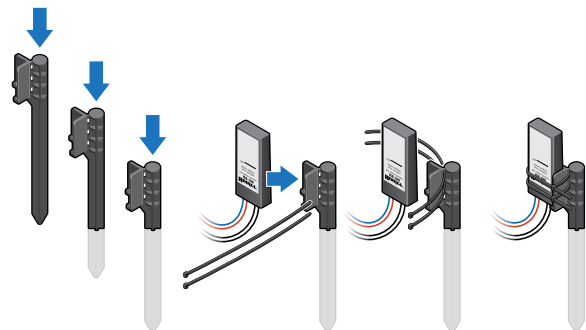

ACC2 DECODER CONTROLLER DESIGN GUIDE

Decoder-to-Solenoid Wiring

- From the decoder outputs to the individual solenoids, use standard irrigation wire sized for the length of the run.
- Wiring from the decoder to the solenoid should not exceed 150' (45 m). If the decoder-to-solenoid distance is over 20' (7 m), use "webbed" or twisted wire to aid in surge suppression. This is especially important in high lightning areas.

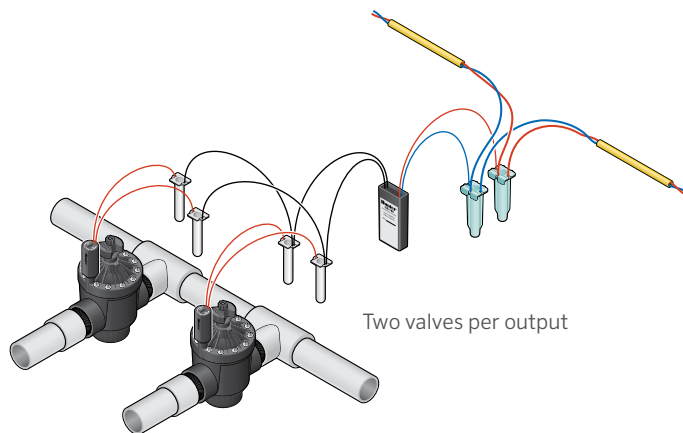

- The decoder is often in the same valve box as its solenoids. In these cases, standard 18 AWG (0.8 mm²) wire is acceptable.
- Each decoder output has the capacity to operate two standard Hunter solenoids. When doubling solenoids on a decoder output, wire them in parallel rather than in a series. The decoder station output leads should run to the two leads from the first solenoid, then connect (usually in a three-way splice) to the leads from the second solenoid.

Decoder Outputs, Power Factors, and Inrush

The individual decoder station outputs are designed to operate standard 24 VAC irrigation solenoids. While solenoids vary, inrush current is normally around 0.250 Amps AC on a Hunter solenoid with a holding current around 0.200 Amps AC. Solenoids from other manufacturers may vary considerably, and there are high-draw solenoids that may greatly exceed these values.

A Hunter ICD Decoder output normally has enough energy to operate two standard Hunter solenoids. They may not necessarily operate two solenoids for any model of solenoid, and the exact solenoid specifications should be consulted before planning a system.

Each color-coded station output from a decoder module generates energy to operate 24 VAC solenoids. However, this energy is not running at 50/60 Hz and will not look like 24 V on a conventional voltmeter.

A special note about Amps: The decoder path current is different than 24 VAC line current (running at 50/60 Hz). The decoder output modules and Hunter ICD-HP Programmer measure decoder amperage. This is why a

solenoid on an active decoder station may show 40 mA, when the same solenoid in a 24 VAC system is consuming 200 mA of traditional AC current.

The power factor for decoders defaults to "2" and represents the amount of energy supplied to the solenoid. Leave this setting at "2" unless advised to change it by Hunter technical personnel.

The inrush setting defaults to "5," which is the correct setting for most applications. Some high-draw solenoids and pump start relays may require higher inrush settings, but this is also best determined with Hunter Tech Support.

Wire runs from decoder to solenoid over 20' (7 m) should use twisted wire to aid in surge suppression. This has been proven to work in high lightning regions, and it's a wise precaution in any decoder system. It's possible, though not necessary, to use IDWIRE for decoder-to-solenoid wiring. There are also webbed decoder-to-solenoid (DTS) wires available for a neat solution to longer runs (i.e., Paige Electric DTS wires spec P7351D).

ACC2 DECODER CONTROLLER DESIGN GUIDE

Decoder Hardware and Models

You may order ACC2 Controllers in decoder versions as complete model numbers.

Decoder and conventional output modules come in different configurations, so avoid installing them in the same controller at the same time.

ACC2 DECODER MODELS

Model	Description
A2C-75D-M	75-station base model, gray metal outdoor, wall mount
A2C-75D-P	75-station base model, plastic outdoor, wall mount
A2C-75D-SS	75-station base model, stainless steel, wall mount
A2C-75D-PP	75-station base model, plastic pedestal

A2C-75D-M:

- ACC Decoder Controller with standard, powder-coated steel wall mount and output
- Allows up to 75 decoder stations (max 225 with additional modules)
- Can be installed on the ACC-PED matching gray stainless steel pedestal

A2C-75D-P:

- ACC2 Decoder Controller with plastic wall mount and output
- Allows up to 75 decoder stations (max 225 with additional modules)
- Plastic cabinet is lighter, corrosion-resistant, and includes same internal components and features as the metal wall mount

A2C-75D-SS:

- ACC2 Decoder Controller with stainless steel wall mount and output
- Allows up to 75 decoder stations (max 225 with additional modules)
- Can be installed on the PED-SS matching gray stainless steel pedestal

A2C-75D-PP:

- ACC Decoder Controller with plastic pedestal and output
- Allows up to 75 decoder stations (max 225 with additional modules)

A2C-D75:

- ACC2 Decoder Output Module
- For use with existing A2C-75-Dxx Controllers
- Expands station operation
- Included in base ACC and ACC2 Decoder Controllers
- Two more modules may be added per controller to expand to 150 or 225 stations

ACC2 Controllers (including decoder variations) are capable of either 120 VAC or 230 VAC operation and do not require separate versions for international markets.

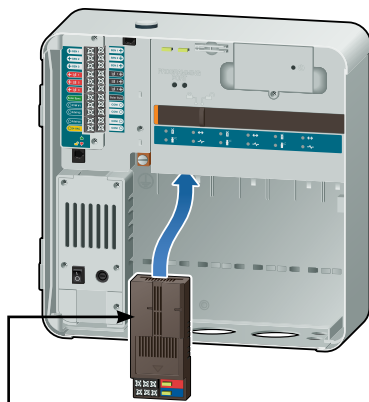

A2C-D75 Decoder Output Module

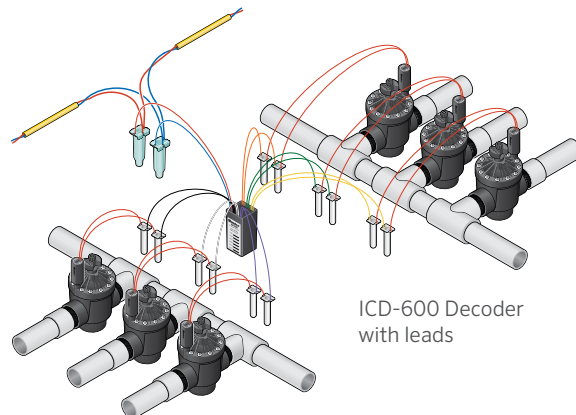

ICD-600 Decoder with leads

ACC2 DECODER CONTROLLER DESIGN GUIDE

Decoder Hardware and Models (continued)

ICD Decoder Models

ICD Decoders are waterproof and feature integrated surge suppression with copper ground wire. Multi-station decoders use color-coded wire leads for each station output.

DECODER MODELS	
Model	Description
ICD-100	Single-station decoder with surge suppression and ground wire
ICD-200	2-station decoder with surge suppression and ground wire
ICD-400	4-station decoder with surge suppression and ground wire
ICD-600	6-station decoder with surge suppression and ground wire
ICD-SEN	2-input sensor decoder with surge suppression and ground wire

UNIVERSAL DECODER STAKE	
Model	Description
DECSTAKE10	Universal Decoder Stake (10 per carton), zip ties included

Each ICD Decoder has one red and one blue communication wire that are used for connecting to the two-wire path. IDWIRE is color-coded to make installation and service easy.

The single-station Hunter ICD-100 Decoder has a single pair of black wires for connecting to the solenoid. Generally, this can power up to two standard 24 VAC solenoids at the same time, regardless of the distance from the controller (subject to the limits of the IDWIRE used on the project).

Multi-station decoders have additional color-coded pairs, corresponding to individual station outputs. Each station can be turned on independently of the others, and each station output can activate two solenoids. Theoretically, each multi-station decoder can activate the number of stations times two solenoids simultaneously. Some limits may apply for very high-draw solenoids and pump start relays.

ICD Decoders are CE Certified for international regulations and meet other relevant international standards as well. Note that the decoders themselves are low-voltage products that are not eligible for separate UL/c-UL Listings on their own. They are part of a UL Listed/c-UL decoder controller system with the A2C-75Dxx family of controllers.

Programming Decoders

ICD Decoders are station-programmable. Each decoder arrives with blank station addresses, and the addresses can be assigned from the controller before the decoder is placed in the two-wire path. It's also possible to program decoders in field installations with the wireless, handheld ICD- HP Programmer.

Decoders may be programmed and labeled at the controller prior to installation or at any time with the ICD-HP Programmer.

The programming process is straightforward and simple.

1. Insert the red and blue wires from the decoder into the programming ports on the upper deck lid of the internal controller. (See image below.)
2. Turn the controller dial to select the Decoder menu, then the Program Decoder function.
3. Select the Decoder Location to read the configuration of the attached decoder, and enter the station numbers you want the decoder to receive.
4. Press the program decoder button to complete the process.
5. The decoder is now programmed. Be sure to label the metallic tag on the decoder with a permanent marker.
6. To reprogram the decoder, repeat this process.

When using the ICD-HP Programmer (highly recommended), you can install blank decoders first, then program them in place. This requires power on the two-wire path. You can also use the device's diagnostic functions for troubleshooting.

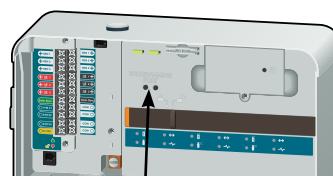

Programming port

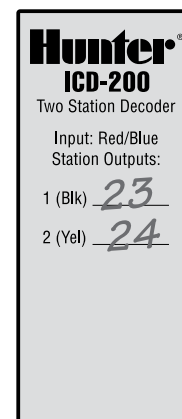

Metal decoder tag

ACC2 DECODER CONTROLLER DESIGN GUIDE

Decoder Hardware and Models (continued)

Programming Decoders

Note
Do not create duplicate station addresses for decoders.

A2C-75Dxx and ICD Decoders use two-way communications on the two-wire path. Each command from the controller (e.g., turn on or off) requires an answer from the decoder. If multiple units with the same address try to respond, one or both will not be heard, and errors will result.

The ACC2 Decoder Controller has several methods for running multiple stations simultaneously, including overlapping programs and the innovative use of "Blocks." Do not program duplicate addresses to try to achieve this.

To expand a system after initial installation, add a new decoder anywhere in the two-wire path. You can assign a name for each station in the ACC2 Controller. Stations do not need to be in numerical order. However, you may readdress the stations if keeping them in order is of primary importance.

ICD-HP Programmer

The rugged, battery-operated ICD-HP is a unique tool for programming and running diagnostics for both Hunter ICD and DUAL® Decoder Systems.

The handheld programmer uses wireless induction to communicate with decoders through the plastic case. This makes it possible to read, program, or reprogram decoders

without disconnecting any waterproof connectors, even when fully wired in valve box installations.

The ICD-HP also lets you operate the solenoid as well as check solenoid status and current draw. It includes sensor checks for Hunter Clik and Flow-Sync® Sensors too. While not a requirement, the ICD-HP is a highly recommended option for any professional decoder installer or maintenance organization.

Pump Starts

Part of the tremendous flexibility of ACC2 Decoder Systems is the ability to designate decoders on the two-wire path as Pump/Master Valve (P/MV) outputs. This allows the ACC2 Decoder Controller to operate dedicated P/MV outputs thousands of feet (or meters) away from the controller without running extra wire.

All ACC2 Controller models have up to six programmable P/MV outputs, programmable by station. Up to three P/MV outputs can be connected directly to the controller's power supply board terminals. Up to six can be operated by ICD-100 station decoders if they're assigned as P/MVs.

In ACC2 Decoder Systems, one or more P/MVs can be operated via the two-wire path. The ACC2 Decoder

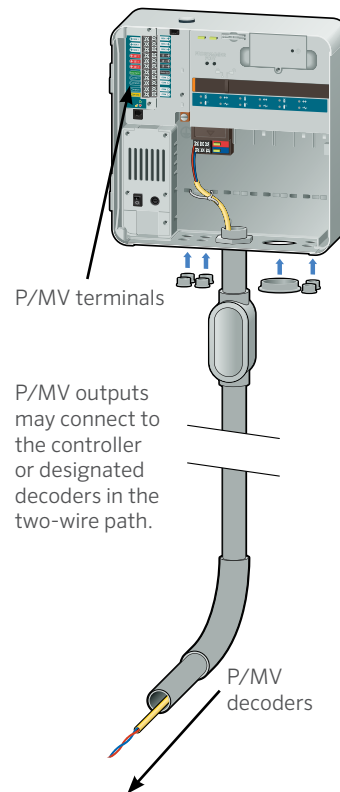
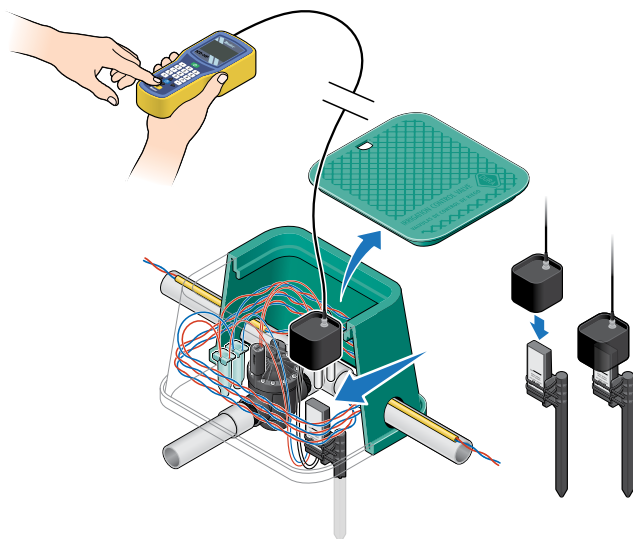

ACC2 DECODER CONTROLLER DESIGN GUIDE

Decoder Hardware and Models (continued)

Controllers can use the P/MV terminals in the controller on the power supply board with their own wire. Or they can operate dedicated pump decoders on the decoder path. It's possible to use any combination of terminals or decoders up to the maximum of six P/MVs, giving you the ability to choose how to reach them. Simply select the individual P/MV output locations (controller or decoder) at the decoder controller facepack in the Devices menu.

Use a single-station ICD-100 Decoder for P/MV purposes. When a decoder is assigned as a pump decoder, it's completely dedicated to that purpose and will lose the ability to operate any other stations. Make sure the relay is rated for this purpose and that the decoder is completely isolated from the high voltage side of the switch.

ICD-SEN (ACC2 Systems Only)

The ICD-SEN Sensor Decoder is a special type of decoder module designed to accept inputs (from sensors) rather than outputs to stations.

Each ICD-SEN has two sensor ports, which can report sensor status back up the two-wire path to the ACC2 Controller.

You can set up sensor decoders at the controller, using the programming port on the output module. They have a unique series of setup screens in the controller display. ICD-SEN Decoders may also be programmed and set up with the ICD-HP Programmer.

Like the other decoders, each ICD-SEN has a red and a blue wire for connecting to the two-wire path and a bare ground wire. However, each ICD-SEN also has two color-coded loops called "ports."

Hunter Flow-Sync Sensors or Klik-type sensors can be connected and reported via the two-wire path. Other flow sensor brands can also be connected via the ICD-SEN.

The flow meter can only be connected to Port A. Klik sensors may be connected to either port, as needed. ICD-SEN is not compatible with the Solar Sync® Sensor and is not used for Solar Sync controller connections.

Powered and Wireless Klik Receivers

ICD-SEN Sensor Decoders do not supply 24 V power for Hunter's Klik receivers, such as the Wireless Rain-Klik® and Flow-Klik® Sensors.

They'll work with the switch closures these sensors provide, but wireless receivers or those powered separately require a 24 VAC power source near the receiver. Since ICD-SEN Sensor Decoders are usually located far from the controller,

the wireless receiver power supply should be determined and provided in advance of installation in the vicinity of the ICD-SEN. The wireless sensors may then be located within their normal range of the receiver. ICD-SEN accepts the unpowered Klik output of these sensors once they have a power supply.

ACC2 Controllers never have more than six flow meters and nine Klik sensors, regardless of how and where they're connected. It's the designer's or installer's choice whether they're connected to the terminals on the controller's master module or the two-wire path through an ICD-SEN.

There can be nine ICD-SEN Decoders connected to the two-wire paths for a single controller. Some could monitor flow from a flow sensor, and each of the others could monitor a single Klik sensor.

Wireless Remote Controls (ICR, ROAM Remotes, and Maintenance Radios)

With Hunter remotes, set the ROAM Remote mode to 240 and the ROAM XL Remote to COMM for decoder controllers.

 **Note** Setting station max to 240 will prevent the remote from operating other Hunter controllers, such as the ICC Controller. Reset the max station size when using the remote with both Hunter decoder controllers and other Hunter controllers.

- ROAM Remotes are fully compatible with ACC2 Decoders and require no license in most international installations.

Central Control

You may connect all ACC2 Controllers to internet-hosted Centralus™ central control for remote programming as well as alarm and flow reporting.

Just insert a communication module in the back of the control panel. Three connection types are available:

- A2C-WIFI for 2.4 GHz wireless connection to a router; antenna included
- A2C-LAN for Ethernet connection to a network
- A2C-LTEM for 4G LTE cellular connectivity, antenna included; this uses either CAT-M! or NB-IOT service to connect
 - A2C-LTEM is supplied with a Hunter SIM card and requires a service plan. It's also possible to obtain a SIM locally from a compatible carrier.

ACC2 Decoder Installation Specifications

Cable layout and design is relatively simple for an ACC2 Decoder System. The general rule is to run the two-wire paths in the pipe trenches so they pass near each valve location. In special circumstances, or if cable sizes need to be trimmed down to a minimum, the formulas in this document can be used. The second section describes how to design the surge protection system.

Cable

It's important to always use a solid core, color-coded, twisted-pair cable. The twist of the cores protects the system from most types of noise and small surges. This is the same technology that has been used by telephone and data companies for many years (with smaller wires). Do not use two straight single cores, even though it works in most cases, because the surge resistance will be diminished. Select the cable size according to run distance and the number of passive and active decoders on the path.

As a general rule, IDWIRE1 (14 AWG; 1.6 mm diameter; 2.08 mm² area) is recommended for wire path lengths up to 10,000' (3,000 m) and IDWIRE2 (12 AWG; 2 mm diameter; 3.3 mm² area) for wire path lengths up to 15,000' (4,500 m). These maximum wire path lengths are used when activating two Hunter solenoids with up to 225 decoders idle in the system. If the system needs to activate more than two solenoids at a time, the maximum wire length must be calculated. For a more exact maximum length, check the Cable Design Formulas section on page 15. Be sure to focus on the length from the controller to the furthest decoder on each path, NOT the total system cable length. Avoid running power and decoder cables in parallel, especially if they're close. If a high-voltage cable must be crossed, it's best to cross at right angles.

Layout

The maximum number of decoders on one A2C-D75 Output Module is 75 stations, up to six P/MVs, and up to nine sensor decoders. Each station decoder can have a maximum of two Hunter solenoids per decoder output.

A cable path can be branched off as many times as necessary. If the branches are long, use a decoder cable switch device (Paige 270DCSD or equal) to isolate the branches for troubleshooting purposes.

With normal installations, no calculation on wire path length is needed if you follow the general design rule of two maximum stations active at once.

Under special circumstances, the formulas on page 15 can be used. These formulas assume that the decoders are spread evenly over the wire path. A more exact calculation can be done based on the following data:

- Maximum allowed voltage drop is 14 V
- Passive (standby) decoder current is approximately 1.5 mA
- Active solenoid current is approximately 45 mA per solenoid

Using these values and Ohm's Law, the wire path can be sectioned and calculated exactly. Don't design a system to operate a 6-station decoder and two solenoids per output (12 total solenoids) at the end of the wire path unless you've calculated the maximum wire length.

It's a best practice to reduce the maximum wire length by 25% to compensate for wire connections, different types of solenoids, and the aging of in-ground copper.



Note

It's only the individual wire path lengths that matter, not the total length of all paths.

One controller can handle a 225-station system (and up to six P/MVs). If you plan to operate a large number of stations simultaneously, however, you must calculate the maximum cable length.

ACC2 DECODER CONTROLLER DESIGN GUIDE

Cable Design Formulas

Wire Path Length Formula

$$L_w = \frac{2 \times V_d \times 1,000'}{R_w \times I_w}$$

L_w = Wire path length in feet or meters (1 pair wires)

V_d = Allowed voltage drop

I_w = Maximum operation current on wire path

R_w = Wire path resistance in ohm/1,000' (330 m) or ohm/km

V_d (Voltage Drop)

V_d = Output - minimum operation voltage

V_d = $(1.4 \times 24 \text{ V}) - 20 \text{ V}$

$V_d \approx 14 \text{ V}$

I_w (Current In Wire Path)

I_w is the sum of all decoders' currents on the wire path and the sum of simultaneous open solenoids.

One decoder uses approximately 1.5 mA (with solenoid off).

One solenoid uses 45 mA (Hunter solenoid marked 250 mA with default Power Factor 2).

I_w = Maximum operation current on wire path

N_d = Number of decoders on wire path

N_s = Number of simultaneously active solenoids (Maximum 30 per ACC2 Controller)

$I_w = (N_d \times 0.0015) + (N_s \times 0.0045)$

R_w (Loop Resistance)

R_w = Loop resistance in ohm/1,000' (330 m) or ohm/km

This resistance varies by cable area, and the actual values need to be verified by the cable manufacturer.

The resistance refers to the out and back resistance or that of both conductors in the two-wire path treated as a single, continuous run.

Cable (1 pair)	R_w ohm/1,000' (330 m)	R_w ohm/km	Comment
#14-2	5.04	16.56	IDWIRE1
2.0 mm-2	~	10.98	Metric Wire Gauge
#12-2	3.18	10.42	IDWIRE2
2.5 mm-2	~	7.02	Metric Wire Gauge
#10-2	2.00	6.55	American Wire Gauge

Wire connectors are not taken into account. Good connections that are properly made add very little resistance, but a safety margin is needed because resistance may increase (up to 25%) in the connectors as they age.

L_w Wire Path Length Formula:

L_w = Wire path length in feet or meters

$$L_w = \frac{2 \times V_d \times 1,000'}{R_w \times I_w}$$

ACC2 DECODER CONTROLLER DESIGN GUIDE

Cable Design Formulas (continued)

Examples

All 225 decoders (A2C-75D Controller with 225 stations including six P/MVs assigned to decoders) on a single-wire path with the maximum 20 solenoids active (10 programs with two solenoids per station plus six P/MVs) on one 14 AWG (2.08 mm²) IDWIRE2 path.

English

$$L_w = \frac{2 \times 14 \times 1,000'}{3.18 ((225 \times 0.0015) + (20 \times 0.045))} = 7,115'$$

Metric

$$L_w = \frac{2 \times 14 \times 1,000'}{7.02 ((225 \times 0.0015) + (20 \times 0.045))} = 2,459 \text{ m}$$

80 decoders with five solenoids active on one 14 AWG (2.08 mm²) IDWIRE1 path

English

$$L_w = \frac{2 \times 14 \times 1,000'}{5.04 ((80 \times 0.0015) + (5 \times 0.045))} = 16,103'$$

Metric

$$L_w = \frac{2 \times 14 \times 1,000'}{10.98 ((80 \times 0.0015) + (5 \times 0.045))} = 7,392 \text{ m}$$

Conditions:

- The decoders and active solenoids are evenly spread over the path.
- Good wire connectors are used.
- Decoders are set up for Power Factor 2 (default).

Design Suggestions:

We recommend reducing maximum length by 25% to compensate for wire connections, different types of solenoids, and aging.

ACC2 DECODER CONTROLLER DESIGN GUIDE

Cables from Decoder to Solenoid(s)

A decoder system should include one decoder per solenoid (valve or head). Placing the decoder near the solenoid enables maximum irrigation control, minimum wiring, easy installation, and simple documentation.

When multiple solenoids will be activated by one decoder, or you plan to use multi-station decoders (ICD-200, ICD-400 and ICD-600), run cables between the decoder and the solenoids. Place the decoder as close to the solenoid as possible, and use a twisted pair cable between the decoder and the solenoids. Do NOT connect the solenoids together with a common wire. Always use one pair for each output

from the decoder. If two solenoids will be fed from the same decoder output, run wire from the decoder to the first solenoid, then from the first to the second. This allows the solenoids to be connected parallel to the decoder output.

In high lightning areas, we don't recommend having more than 100' to 150' (30 m to 45 m) cable lengths between decoders and solenoids. Longer lengths can be used, but it increases the risk of lightning damage to the decoder and solenoids. Suppliers such as Paige Electric now offer color-coded "DTS" (decoder-to-solenoid) wire pairs for this purpose.



Paige DTS (decoder-to-solenoid) Wire

Multiple Solenoids from One Decoder Output

A maximum of two standard Hunter solenoids can be connected to a decoder output.

The multi-station decoders can also have two solenoids per output, but the number of outputs that will activate simultaneously on a decoder depends on the available voltage at that point in the two-wire path. The cable design formulas are used to factor in the distance from the controller to the decoder, the Power Factor setting of the decoder, and

the number of solenoids connected to the decoder. ACC2 Controllers are designed to handle 20 active solenoids (up to two per station plus two P/MV outputs) simultaneously, or up to 30 simultaneous stations if more than one output module is installed. When in doubt, use the formulas to design the maximum wire length with the worst case number of simultaneous solenoids active.

Power Factor

The Power Factor setting in the controller for each decoder controls how much power the solenoid gets. It's rarely necessary to change from the default value of 2. For heavy-duty solenoids or solenoids far away from the controller,

it may be necessary to increase the Power Factor if the solenoid does not activate with a setting of 2. This setting may also assist with high inrush pump start relays.



hunter.help/ACC2Decoder

ACC2 DECODER CONTROLLER DESIGN GUIDE

Surge Protection

A good surge protection system safeguards an irrigation system from small to medium lightning storm effects and minimizes the impact of large lightning storms.

To achieve the minimum recommended level of protection, place one grounded decoder at the end of each wire path and one grounded decoder every 1,000' (300 m) or 12th decoder. For higher levels of protection, ground the decoders more frequently. There is no limit on the number of ground connections you can use in a decoder system.

It's important that both the controller and decoders are grounded to ground rods or plates with less than 10 ohms of resistance. The ground should always be measured with a

ground resistance meter. A "clamp-on meter" cannot be used for ground measurement since this is an isolated system. Ground resistance measurements should be performed with a "fall of potential" type meter in decoder systems. The ground should be tested regularly for resistance.

Surge protection inside the decoder can wear out, and a decoder should be replaced if there's any chance it could have been damaged by a lightning strike in the immediate vicinity. The decoder is a complex electronic part and it's not possible to fully test whether it's working. Replace the decoder if there is any visible damage to the device or if nearby decoders or controllers have been damaged.

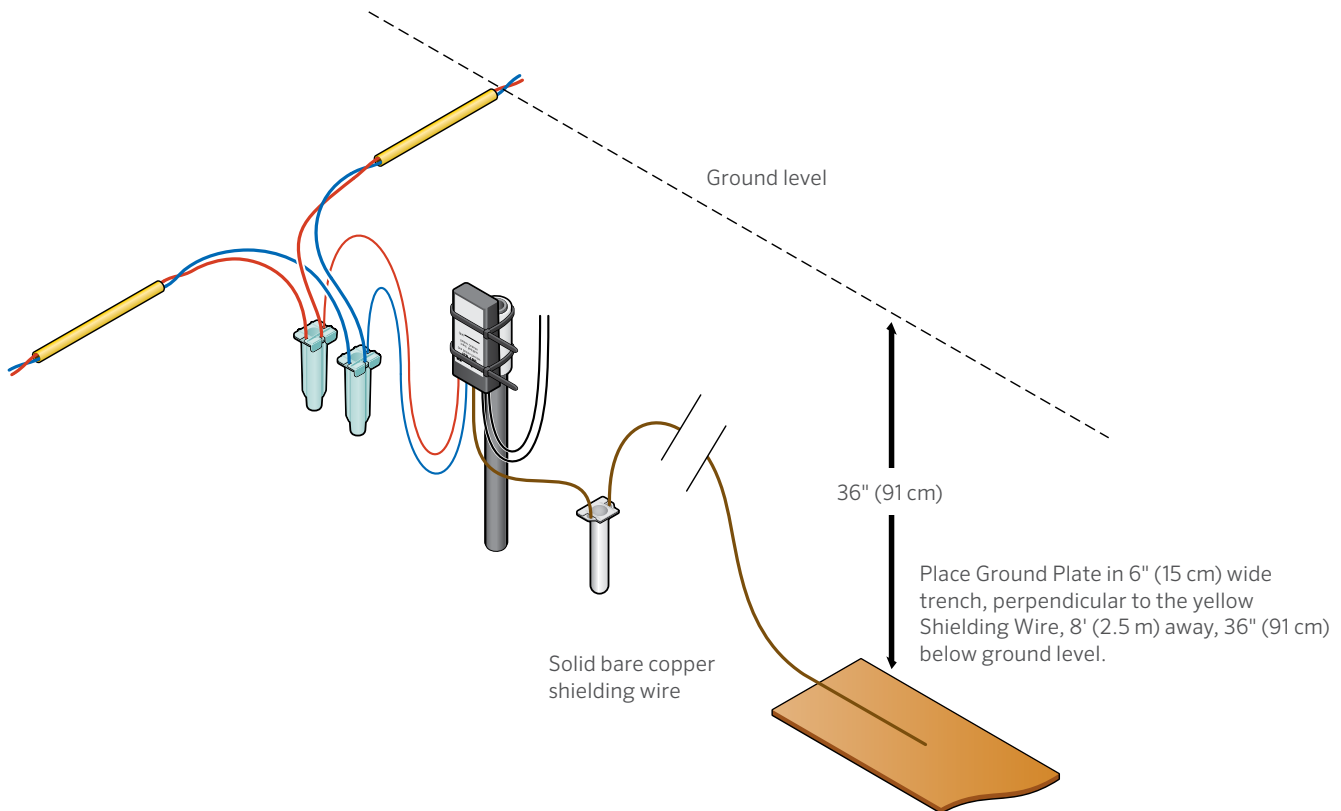

ACC2 DECODER CONTROLLER DESIGN GUIDE

Earth Grounding Hunter Decoder Systems

It's the contractor's responsibility to ground all electrical equipment installed in relation to an irrigation control system. Grounding components will include, but not be limited to, the items described in the following paragraphs.

Use grounding electrodes that are UL listed or manufactured to meet the minimum requirements of the U.S. National Electrical Code (NEC).

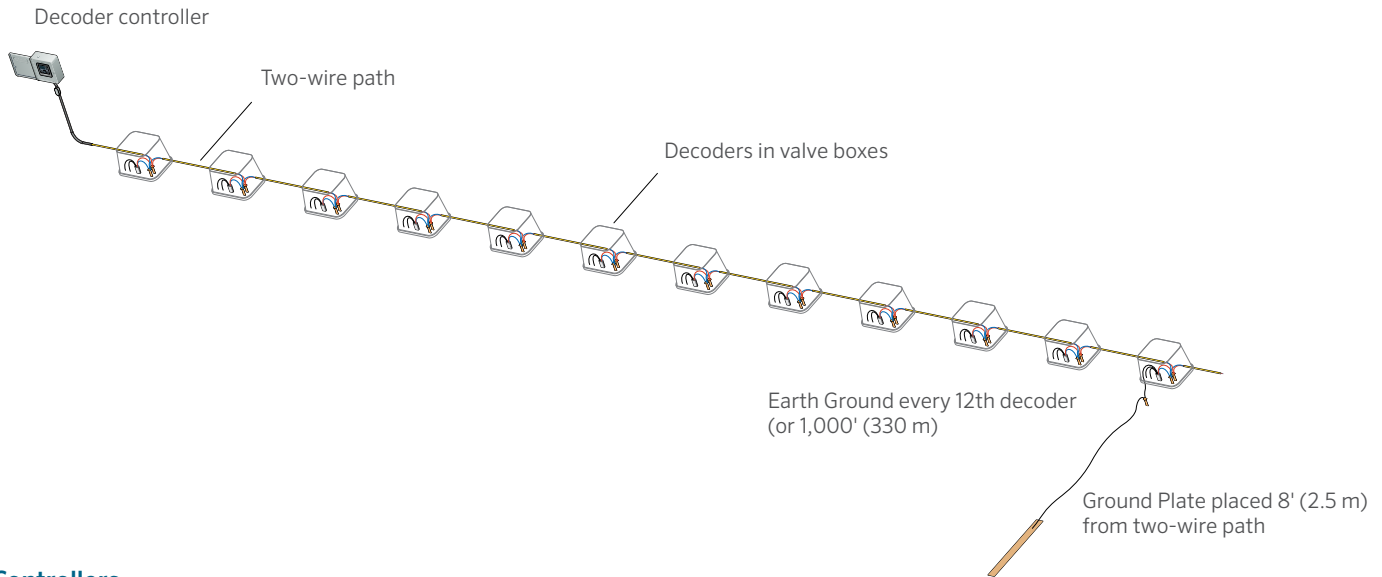

Controllers

At minimum, the grounding circuit for controllers should include a copper clad steel ground rod, a copper ground plate, and 100 lb (45 kg) of PowerSet® earth contact material, as described below.

Ground rods should have a minimum diameter of $\frac{5}{8}$ " (1.5 cm) and a minimum length of 10' (3 m). Drive each rod into the ground in a vertical position or at an oblique angle not to exceed 45°. Position it at a location 8' to 10' (2.4 m to 3 m) from the electronic equipment or the wires and cables connected to it and at right angles to the two-wire path. It should be stamped as UL listed (Paige Electric part number 182007).

The copper grounding plate assemblies (Paige Electric part number 182199L) must meet the minimum requirements of Section 250 of the NEC. They should be made of a copper alloy intended for grounding applications with a minimum dimension of 4" x 96" x 0.0625" (100 mm x 1.2 m x 1.6 mm). A 25' (8 m) continuous length (no splices allowed unless using exothermic welding process) of 6 AWG (4 mm²) solid, bare copper wire should be attached to the plate using an approved welding process. During the resistance test process, you may use mechanical clamps with a radius of 8" (20 cm) and a minimum included angle of 90°, but this must be replaced with Cadweld® One-Shot Kits immediately following the test. Install the ground plate to a minimum depth of 30" (75 cm), or below the frost line if it's

lower than 30" (75 cm), at a location of 15' to 20' (4.5 m to 6 m) from the ground rod, electronic equipment and wires and cables. Spread 100 lb (45 kg) of PowerSet (Paige Electric part number 1820058) earth contact material so that it surrounds the copper plate evenly along its length within a 6" (15 cm) wide trench. Do not use salt, fertilizer, or other chemicals to improve soil conductivity. These materials are corrosive and will cause the copper electrodes to erode and become less effective with time.

Install all grounding circuit components in straight lines. When it's necessary to make bends, don't make sharp turns. To prevent the electrode-discharged energy from reentering the underground wires and cables, install all electrodes away from the wires and cables. The spacing between any two electrodes should be 15' to 20' (4.5 m to 6 m) so they don't compete for the same soil.

Measure the earth-to-ground resistance of this circuit using a Megger® Earth Ground Tester or other similar instrument. The reading should be no more than 10 ohms. If the resistance is more than 10 ohms, install additional ground plates and PowerSet® earth contact material in the direction of the irrigated area. The soil surrounding copper electrodes must be kept at a minimum moisture level of 15% at all times by dedicating an irrigation station at each controller location.

ACC2 DECODER CONTROLLER DESIGN GUIDE

Earth Grounding Hunter Decoder Systems (continued)

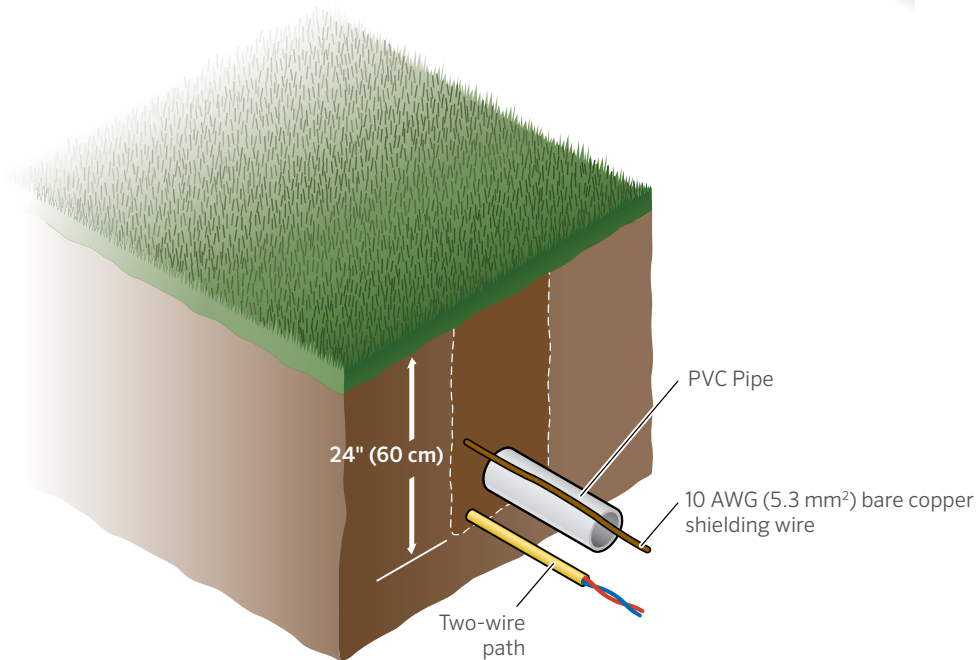
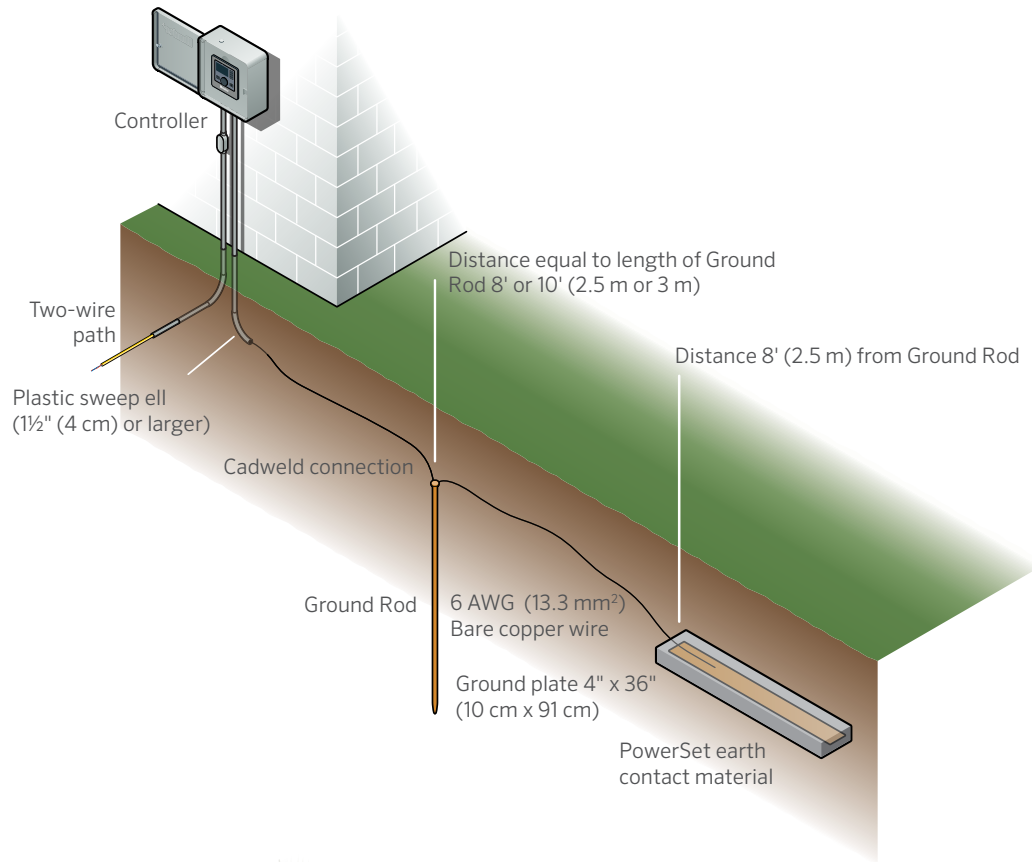

ACC2 DECODER CONTROLLER DESIGN GUIDE

Earth Grounding Hunter Decoder Systems (continued)

Decoder Grounding

At minimum, the grounding circuit for a decoder should include a copper ground plate and may also include 50 lb (22 kg) of PowerSet® earth contact material, as described below.

The copper grounding plate assemblies (Paige Electric part number 182201) must meet the minimum requirements of Section 250 of the NEC. They must be made of a copper alloy intended for grounding applications and have minimum dimensions of 4" x 36" x 0.0625" (100 mm x 1.2 m x 1.6 mm). A 10' (3 m) continuous length (no splices allowed unless using exothermic welding process) of 10 AWG (5 mm²) solid bare copper wire should be attached to the plate using an approved welding process. This wire must be connected to the decoder's ground wire and 10 AWG (5 mm²) bare copper "shielding wire" as shown in the wiring details. A 50 lb (22 kg) bag of PowerSet earth contact material (Paige Electric part number 1820058) must be spread so that it surrounds the copper plate evenly along its length within a 6" (15 cm) wide trench as detailed below. Do not use salt, fertilizer, or other chemicals to

improve soil conductivity. These materials are corrosive and will cause the copper conductors and electrodes to erode and become less effective with time.

Install all grounding circuit components in straight lines. When it's necessary to make bends, don't make sharp turns. To prevent the electrode-discharged energy from reentering the underground cables, all electrodes must be installed 6' to 8' (2 m to 2.5 m) away from the cables and at right angles to the two-wire path. If more than one electrode is used to achieve lower resistance, the spacing between any two electrodes must be 15' to 20' (4.5 m to 6 m), so they don't compete for the same soil.

The earth-to-ground resistance of this circuit should be no more than 10 ohms. If the resistance is more than 10 ohms, install additional ground plates and PowerSet earth contact material in the direction of the irrigated area. The soil surrounding the copper electrodes must be kept at a minimum moisture level of 15% at all times by dedicating an irrigation station at each controller location.

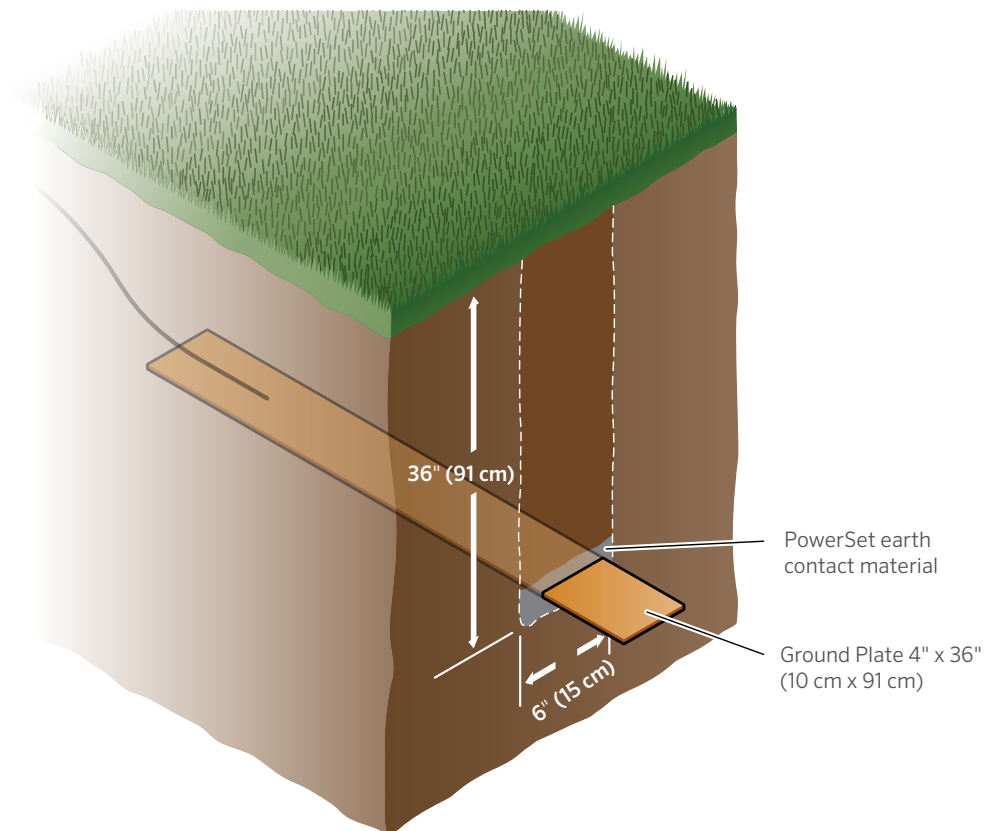

ACC2 DECODER CONTROLLER DESIGN GUIDE

Earth Grounding Hunter Decoder Systems (continued)

Decoder Grounding

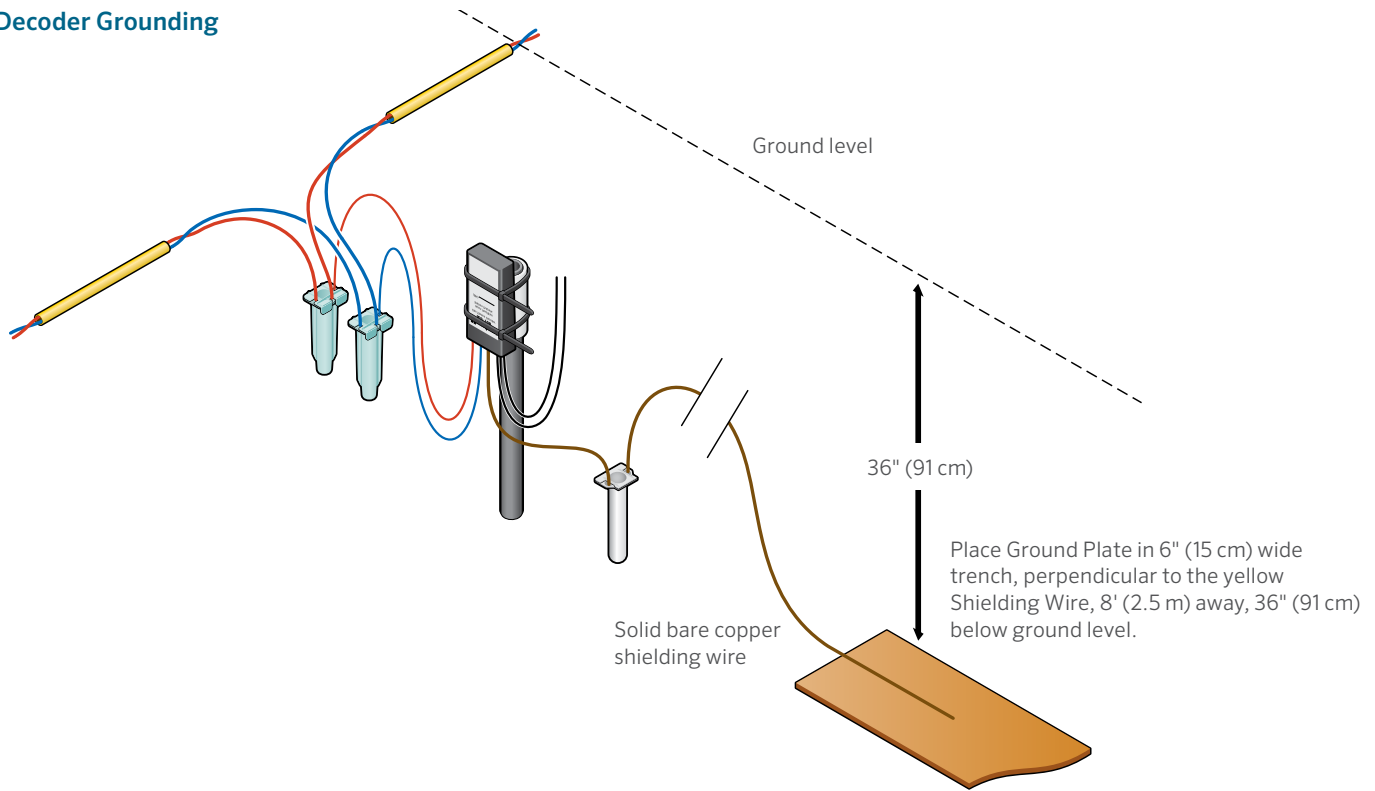

Decoder in valve box

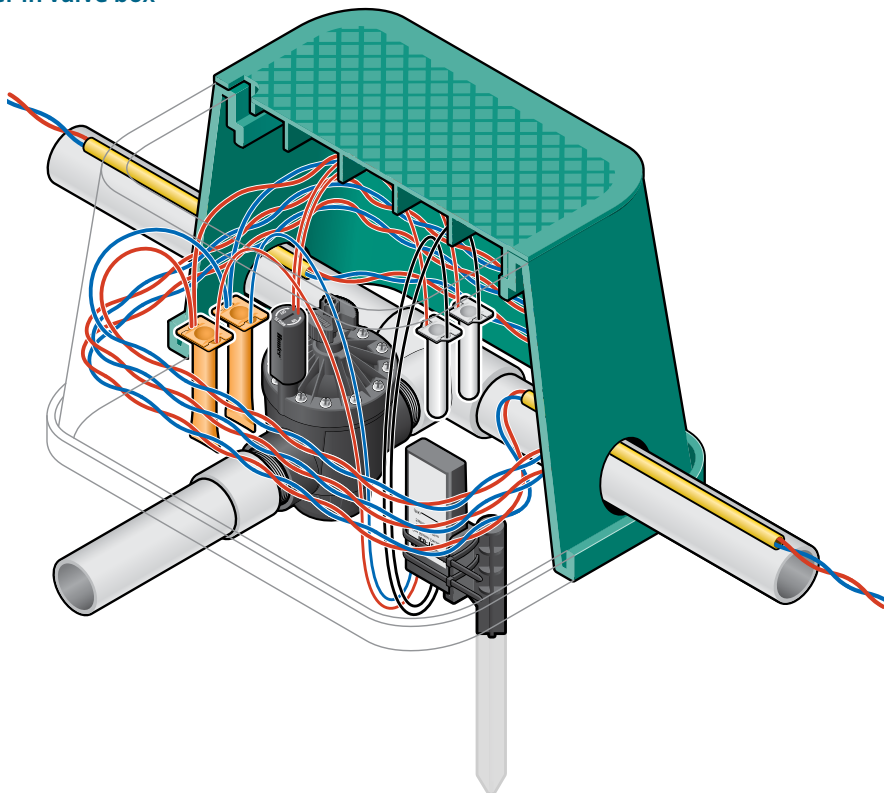

hunter.help/ACC2support

Notes





Helping our customers succeed is what drives us. While our passion for innovation and engineering is built into everything we do, it is our commitment to exceptional support that we hope will keep you in the Hunter family of customers for years to come.

A white, handwritten signature of Gregory R. Hunter.

Gregory R. Hunter, CEO of Hunter Industries

A white, handwritten signature of Denise Mullikin.

Denise Mullikin, President, Landscape Irrigation and Outdoor Lighting

Website hunterindustries.com | **Customer Support** 1-800-383-4747