

# Wireless Valve Link

OWNER'S MANUAL

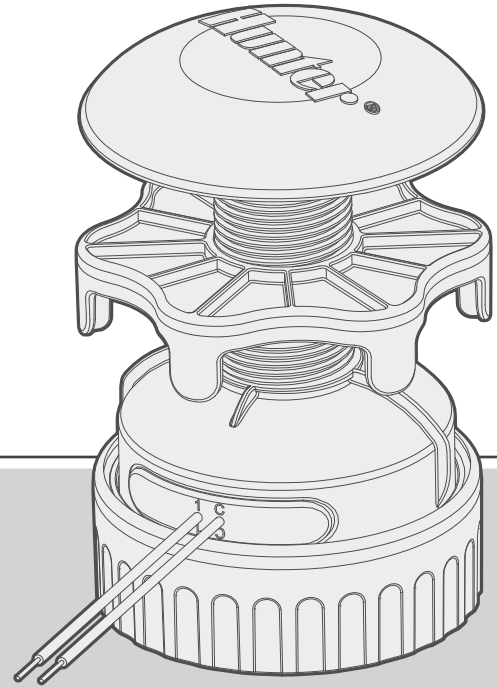

WVL-100, -200, -400  
Wireless Valve Link (WVL)

**Hunter**<sup>®</sup>

# Table of Contents

---

- 3 Introduction
- 6 Station Assignment
- 7 Procedure
- 7 Status Check
- 8 Site Survey/Comm Check
- 8 Installation
- 10 Manual Solenoid Test
- 11 Factory Reset
- 12 Replacing a Wireless Valve Output Module
- 12 Troubleshooting

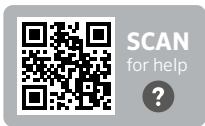

**Need more helpful information on your product? Find tips on installation, controller programming, and more.**

[hunter.help/WVL](https://hunter.help/WVL)

## Introduction

The Hunter Wireless Valve Link System eliminates some of the biggest contractor costs in irrigation installations: copper wire and unnecessary excavation to connect or repair distant valves. Like decoders, it replaces commodity wire with Hunter ingenuity and provides an efficient alternative to activating irrigation valves. Once connected, wireless signals are immune to issues that commonly afflict wired systems, such as wire degradation and lightning damage.

With the Wireless Valve Link, you can add valves up to 2,000' (600 m) line-of-sight, or more with a Repeater, without the need for new valve wiring. Often described as a wireless decoder system, the Wireless Valve Link provides a flexible solution for complex landscapes. Now it's possible to cross concrete sidewalks and asphalt driveways wirelessly, saving time and money during installation.

This convenient and innovative wireless valve technology simplifies installation for landscapes of all sizes by eliminating the need to run costly field wires or cut into hardscape.

- Works with Hunter ICC2 and HCC Controllers and is compatible with Centralus™ and Hydrowise® Software
- Adds up to 54 valves (+P/MV) up to 2,000' (600 m) line-of-sight
- License-free LoRa® Wireless Radio Technology enables wireless communication directly to the valve box — no copper field wiring required
- Optional Wireless Solar Repeater can double wireless communication range
- Connects across ple, Wireardscapes and other obstacles without wiring for seamless system expansion within specified ranges
- Combines with conventional ICM or two-wire EZDS Modules for ultimate flexibility
- Provides isolation from lightning or surge events in the field to prevent system damage
- Optional Solar Panel Kit for Wireless Valve Link eliminates the need to replace alkaline batteries in the field

\*Wireless range is subject to terrain, foliage, buildings, and other site factors. Consult product documentation before installing.

The LoRa® Mark is a trademark of Semtech Corporation or its subsidiaries.

## You will need:

- Free Bluetooth® enabled Hunter WVL App, which is required to perform installation or service. Download it from the Apple or Google Play store below.
- Wireless Valve Output Module installed in Hunter ICC2 or HCC Controller
- 9 V DC batteries (2 per valve recommended)
- 1½" (40 mm) hole saw, included with Wireless Valve Output Module
- Irrigation-grade waterproof connectors
- Permanent marker
- Cordless drill driver and/or jigsaw



*The Bluetooth word mark and logos are registered trademarks owned by Bluetooth SIG Inc. and any use of such marks by Hunter Industries is under license. Apple, the Apple logo, and iPhone are trademarks of Apple Inc., registered in the U.S. and other countries. Google, the Google logo, Android, and Google Play are trademarks of Google LLC.*

## Spare Plastic Parts Kit - 10046600SP

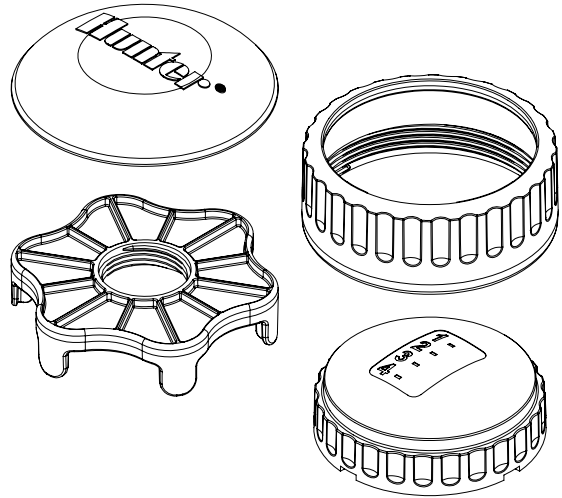

## Spare O-Ring Kit - 10059400SP

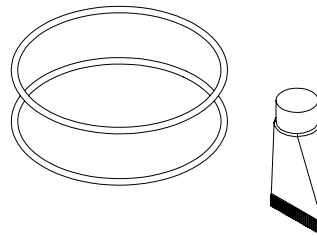

The Wireless Valve Link (WVL) System is a wireless output option for Hunter ICC2 and HCC Controllers. The WVL requires installation of a domestic Hunter Wireless Valve Output Module (WVOM) or its international counterpart (WVOM-E) in a controller output module slot.

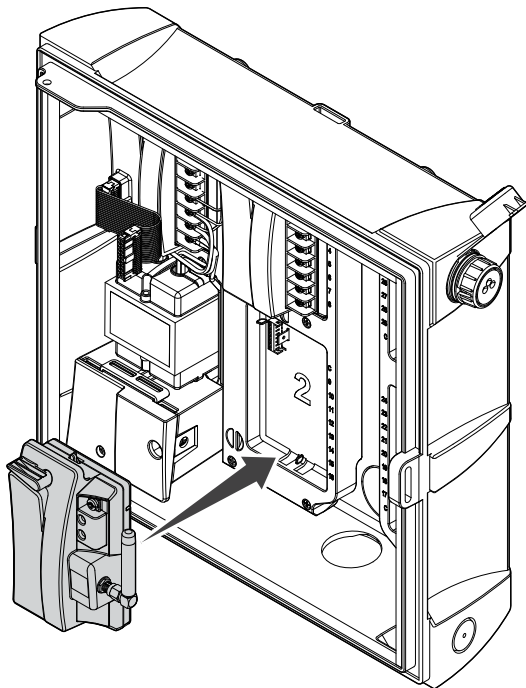

1. Verify that the WVOM is installed in the controller.
2. Make sure the Hunter WVP App is installed on your smartphone.
3. Prepare remote access to the controller using one of the following options:
  - A Hunter ROAM or ROAM XL Remote
  - Centralus™ Software with mobile access
  - Hydrawise® Software with mobile access

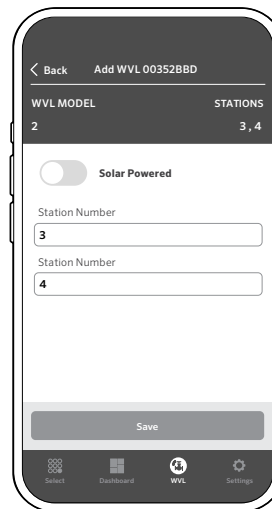

The WVL has two buttons and two LED lights in the battery compartment. These can perform the following functions, in order of importance. Station Assignment and Comm Check require the installation of a WVOM in the controller.

	<b>Feature</b>	<b>Function</b>	<b>Button/Process</b>
1	Station Assignment (REQUIRED)	Assigns controller station numbers to individual output links	Press and hold right button for 2 seconds.
2	Site Survey/Comm Check	Checks radio coverage at proposed installation location	Press left button 3 times.
3	Manual Solenoid Test	Tests solenoid connections and operation directly from the WVL	Press and hold Manual start button. Press to advance.
4	Factory Reset	Erases all programming and assignments	Press right button. Insert battery. Hold button 5 seconds.

### Station Assignment

Bring the WVL to be programmed near the controller location (before installing in the valve box). This insures solid communications before moving to the field location.

Unscrew the battery cover retaining ring. Remove the waterproof cap to reveal the battery compartment.

Install the first battery. You will need to access the right button for station assignment, so installing the first battery on the left is recommended to allow easier access to the button.

Press and hold the right button for approximately 2 seconds. The right LED should turn yellow/green, indicating that the WVL is in Assignment Mode.

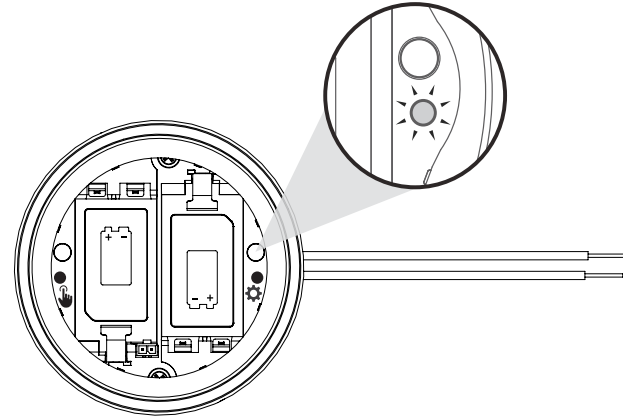

Within 5 minutes, use the Hunter WVL App to add a new station, and allow it to scan for stations while in Assignment Mode.

**!** **Note:** Address one module at a time to avoid duplicate addresses or confusion. After 5 minutes, the WVL will exit the Assignment Mode.  
\*Duplicate addresses should not be used in the WVL System!

## Procedure

1. Place the WVL in Assignment Mode (press and hold right gear button for 2 seconds until right LED is yellow).
2. Open app, scan and connect to the controller. When connected, the screen will show a list of any WVLs already connected.
3. Press (+) to add a WVL, then press the Scan button. The controller will scan for a WVL that is currently in Assignment Mode and display the station numbering options in the app.

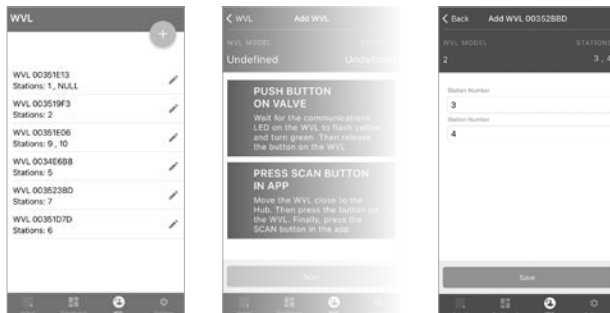

4. Use the app to select the controller station numbers to assign to the WVL. Click Done for each station after it's assigned.
5. Once the WVL stations are assigned, press the Save button. The controller (via the WVOM) will transmit to the WVL to complete the assignment. The app shows if the save was successful. The Assignment (right) light in the WVL will also flash yellow several times when the assignment is successful.
6. After a successful save, install the second 9 V DC battery to improve seasonal battery life (recommended).
7. Take the WVL to the field location.
8. Install and connect the WVL outputs to Hunter DC-Latching Solenoids. Observe red/black wire polarity.

## Status Check

Check the status of any WVL with at least one battery installed. Press and release the Assignment button once. Do not hold the button down.

The Assignment light will show green if stations have been assigned and red if not. The left (Manual) light will show battery status: green if battery is good and red if it needs replacement.

### Site Survey/Comm Check

You can verify radio coverage at the proposed installation/valve box site prior to installation.

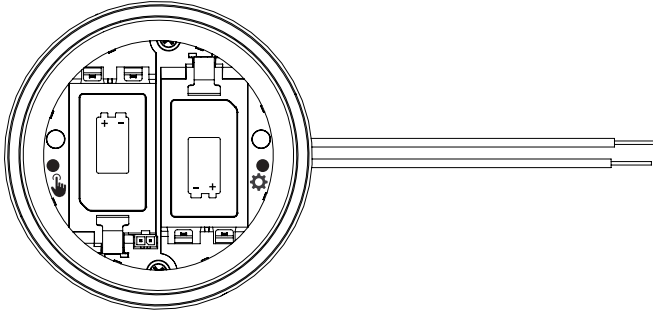

Move the programmed controller to the valve box location, and position it as closely to the final installation as possible.

With the battery compartment open, install at least one battery.

Press the left (Manual) button three times. The LED will blink amber every 2 seconds to show it's listening for the WVOM signal.

Send a manual station start command to any WVL in the system:

- from the controller panel with a helper
- with a Hunter ROAM or ROAM XL Remote
- from a smartphone via central if that is an option

The LED will turn green if it hears the LoRa radio commands from the WVOM. This indicates a probable successful location.

If it does not turn green within a few seconds after the WVOM has sent a command, the signal was not heard.

- a. If the command was sent to the WVL being tested, the LED will turn red.
- b. If the light does not verify communication, you must improve the signal (elevate controller antenna or add a Repeater), or the location may not work reliably.

### Installation

Complete the above steps first, including station assignment. Then proceed to install and connect the WVL in the valve box.

The WVL may be installed in its own valve box, next to the valves it will operate. It can also be installed in the same box as the valves.

Plan ahead to allow sufficient clearance in the valve box before drilling.

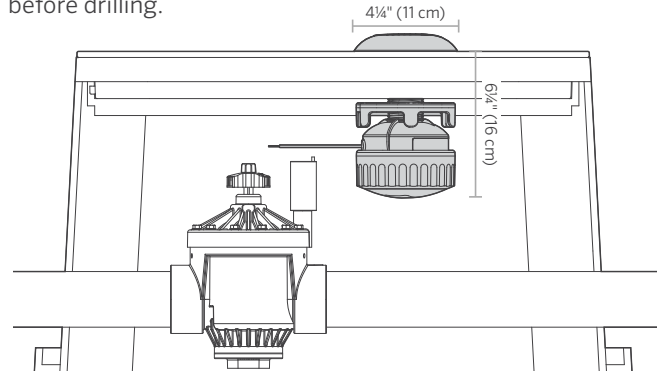



Verify that the WVL assembly will fit in the valve box area without interfering with the valve or other devices in the box.

Final installation requires a minimum 4¼" (11 cm) diameter and 6¼" (16 cm) vertical clearance below the valve box lid.

Determine the center point for the WVL, and drill or use the 1½" (40 mm) hole saw (supplied with each WVOM) into the valve box lid on the center of the WVL location.

**!** **Note:** We recommended drilling to drill upward from the underside of the valve box lid to avoid any reinforcement ribs.

Additional trimming or modifications may be required, depending on the lid material and design. For plastic or fiberglass lids, a handheld jigsaw can remove internal ribs that a hole saw cannot.

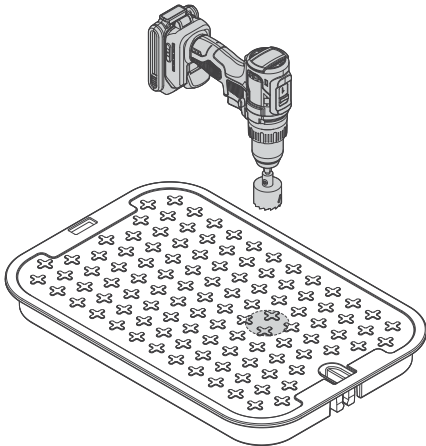

Insert the WVL threaded column up through the hole. Screw on the antenna cap above the valve box lid.

Use the threaded nut to tighten the connection to the underside of the valve box lid.

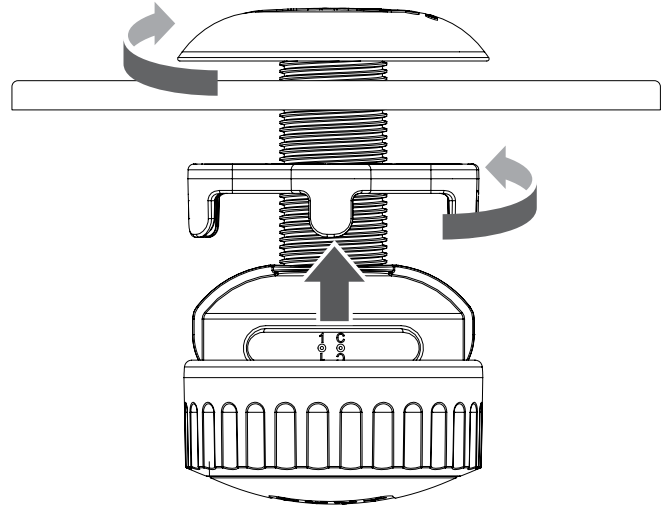

Connect the station output wires to the Hunter DC-Latching Solenoids (458200) in the valve box.

Observe wire color-coding for these solenoids (458200): black to black, red to red. Use the black as a common wire for multi-station WVLs to combine all black wires into a single splice.

This system will not operate with AC Solenoids.

Use irrigation-grade, waterproof connectors for wire splices.

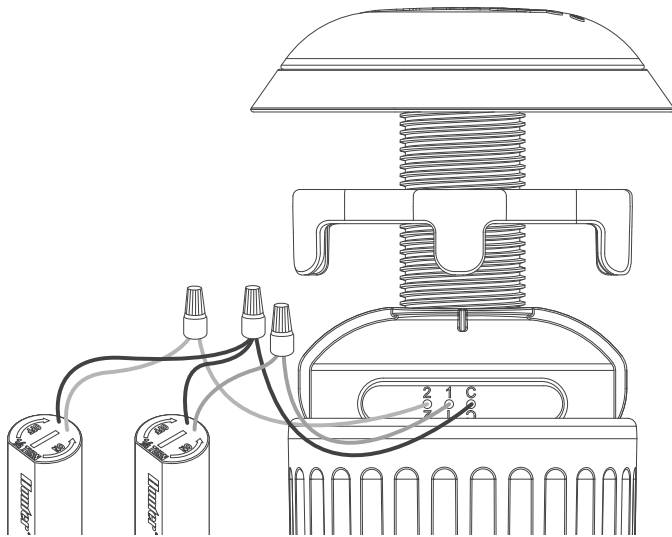

## Manual Solenoid Test

Test connected solenoid operation with the local Manual start button in the battery compartment.

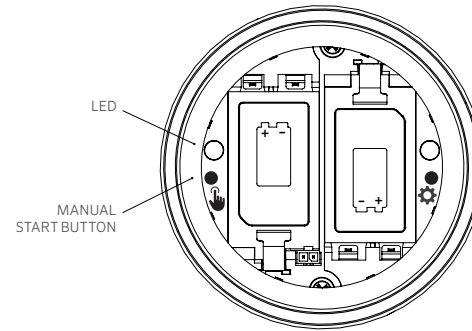

Press and hold the Manual start button (left) to start the first station (blue LED will light and solenoid will click if attached).

Press again to advance to the next station (If it's a multi-station controller).

On multi-station WVLs, the blue light will blink rapidly to show which station output is active.

After the last station starts, press the button one more time to stop all test irrigation. The test function will stop after 1 minute if it does not receive further commands.

Push the battery cap back on firmly, and hand tighten the retaining ring to complete the installation. Make sure the large O-rings remain in place to seal the enclosure.

Replace valve box lid with the installed antenna, and verify proper operation with a controller station start.

## Factory Reset

Factory Reset is used to clear all programming out of a WVL controller, including station assignment, Site ID, and Channel ID.

Procedure:

1. Remove ALL batteries from the WVL.
2. Press and hold the right Assignment button.
3. Continue to hold the button, and insert one battery.  
Continue holding the Assignment button for at least 5 seconds until both LED lights turn red.
4. Release the Assignment button immediately. The WVL will be completely reset.
  - If the reset was successful, both LEDs will turn green momentarily.
  - If the reset was not successful, the LEDs will blink red several times.

Use the app and assignment functions above to add the WVL back into the system, including station assignment.

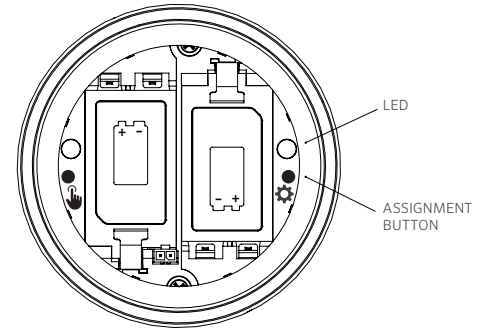

## Replacing a Wireless Valve Output Module

The Recover Database feature is used when a WVOM must be replaced for service reasons or is exchanged with another device.

- The new WVOM must be re-linked to all the WVLs in the field to operate.
- Connect with the app to the new WVOM.
- Install the new WVOM, connect with the app, and choose the Recover Database feature.

- The app will prompt you to enter the serial number of a known device (either a WVL or a Repeater) within the system.
- The WVOM will use this known-good valid serial number to search for that device. The WVOM will then attempt to reach all operational WVLs or a Repeater within range. This can take up to 30 minutes.
- When the process is complete, a notification will appear. If all WVLs were found, the WVOM will be ready to irrigate again without further field addressing.

## Troubleshooting

In most cases, troubleshooting is best done with the Hunter WVL App open on a smartphone.

<b>Problem</b>	<b>Causes</b>	<b>Solution</b>
WVL not watering	Dead batteries. WVL not addressed. Improper solenoid or solenoid disconnected. WVL out of communication range.	Use manual test function, replace batteries. Verify WVL address (start from controller). Use manual test function, check solenoid wiring including polarity (red and black). Improve radio communications.
Multiple stations turn on	Possible duplicate addresses in WVLs	Stop all irrigation, then start one of the stations. If multiple stations start, change the address in one of the WVLs.
Controller beeping	No response from WVL. Low battery warning from WVL.	Use the Hunter WVL App to read which condition is being reported. Replace batteries and/or improve communications, as indicated.
Controller Err display (usually together with beeping)	No response from WVL. Low battery warning from WVL. Possible failure on another output module.	Use the Hunter WVL App to read which condition is being reported. Replace batteries, improve communications, as indicated. Troubleshoot other output modules.
Station turns on for 1 second, then shuts off	WVL is wired to AC Solenoid (not compatible)	Replace the solenoid with the required DC-Latching Solenoid (Hunter model 458200). Red wires to red, black to black.

## FCC

*This device complies with part 15 of the FCC Rules. Operation is subject to the following two conditions: (1) This device may not cause harmful interference, and (2) this device must accept any interference received, including interference that may cause undesired operation.*

*This equipment has been tested and found to comply with the limits for a Class B digital device pursuant to Part 15 of the FCC Rules. These limits are designed to provide reasonable protection against harmful interference in a residential installation. This equipment generates, uses, and can radiate radio frequency energy and, if not installed and used in accordance with the instructions, may cause harmful interference to radio communications. However, there is no guarantee that interference will not occur in a particular installation. If this equipment does cause harmful interference to radio or television reception, which can be determined by turning the equipment off and on, you are encouraged to try to correct the interference by taking one or more of the following measures:*

- *Reorient or relocate the receiving antenna.*
- *Increase the separation between the equipment and receiver.*
- *Connect the equipment into an outlet on a circuit different from that of which the receiver is connected.*
- *Consult the dealer or an experienced radio/TV technician for help.*

*Changes or modifications not expressly approved by Hunter Industries could void the user's authority to operate this device. If necessary, consult a representative of Hunter Industries Inc. or an experienced radio/television technician for additional suggestions.*

*This equipment complies with FCC radiation exposure limits set forth for an uncontrolled environment. In order to avoid the possibility of exceeding the FCC radio frequency exposure limits, human proximity to the antenna shall not be less than 7.9" (20 cm) during normal operation.*

Contains Transmitter Module FCC ID: 3UWVL

## ISED

IC: 2772A-WVL

*This device contains licence-exempt transmitter(s)/receiver(s) that comply with Innovation, Science and Economic Development Canada's licence-exempt RSS(s).*

*Operation is subject to the following two conditions:*

1. *This device may not cause interference.*
2. *This device must accept any interference, including interference that may cause undesired operation of the device.*

*Radiation Exposure Statement:*

*This equipment complies with ISED radiation exposure limits set forth for an uncontrolled environment. This equipment should be installed and operated with greater than 20 cm between the radiator and your body.*

## CE

*Hereby, Hunter Industries declares that the radio equipment type WVL-E-100, WVL-E-200, and WVL-E-400 are in compliance with Directive 2014/53/EU.*

*The full text of the EU declaration of conformity is available at the following internet address: <http://subsite.hunterindustries.com/compliance>*

*Frequency Band (MHz): 434.040 – 434.790*

*Max Output Power (dBm): 6.139*



---

Helping our customers succeed is what drives us. While our passion for innovation and engineering is built into everything we do, it is our commitment to exceptional support that we hope will keep you in the Hunter family of customers for years to come.



**Denise Mullikin, President,  
Landscape Irrigation and Outdoor Lighting**