

SYNTHETIC TURF SYSTEMS

Best-in-Class Solutions for Synthetic Turf Irrigation

Hunter[®]



Attain new levels of playability with
HUNTER ST SYSTEMS



ST-1600 Rotor and Vault System

A Complete Solution for Synthetic Turf Irrigation

The ST-1600 Rotor and Vault System from Hunter Industries is the superior solution for all your synthetic turf irrigation needs. The system brings ST irrigation components together inside one strong enclosure that offers simple access from the top for quick servicing and maintenance. The vault houses a slow-opening, low-pressure-loss control valve, isolation valve, drain valve, quick coupler valve, and a powerful ST-1600 long-range, gear-driven rotor. For large fields, the ST-1600 Rotor can reach a radius up to 50 m. The robust and reliable manifold features premium 80 mm galvanised, ductile iron components with heavy-duty, grooved Victaulic™ fittings. ST Systems allow easy access to all components for better serviceability while seamlessly integrating with a variety of surfaces to keep fields intact, playable, and safe.

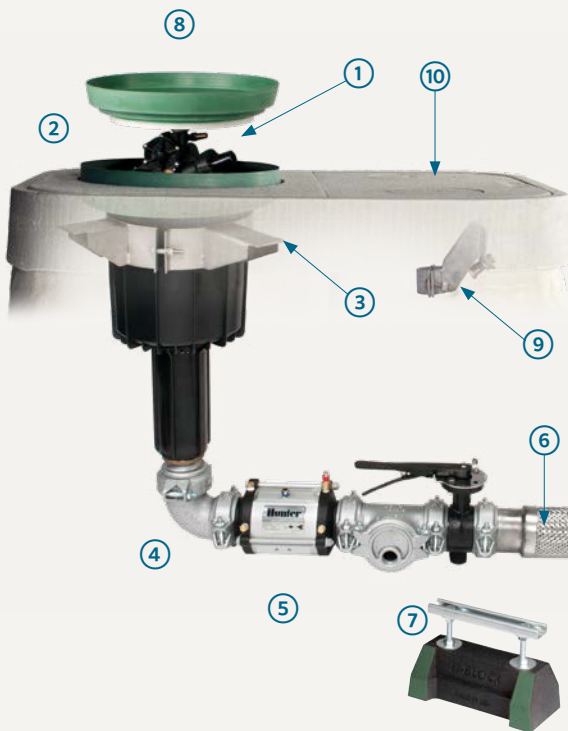

ST-1600-KIT-B SYSTEM COMPONENTS

- | | | |
|----|--------------|--|
| 1 | ST-1600-HS-B | Synthetic turf rotor |
| 2 | ST-243636-B | Vault |
| 3 | ST-BKT-1600 | Bracket for rotor |
| 4 | ST-BVF30-K | Manifold, including 80 mm fittings, isolation valve, and drain valve |
| 5 | ST-V30-KV | 80 mm low-pressure-loss metal valve, including on-off-auto selector and solenoid |
| 6 | ST-H30-K | Adjustable stainless steel alignment hose |
| 7 | ST-SPT-K* | Adjustable manifold support |
| 8 | ST-IBS-1600 | Rubber Cover Kit with ST Infill Barrier System |
| 9 | ST-BKT-QCV | Hanger Bracket for HQ-5-RC Quick Coupler |
| 10 | HQ-5-RC | Quick Coupler 25 mm inlet with 30 mm outlet for key |

* Two required for installation

Victaulic is a trademark of Victaulic Company.

ST-1600 Rotor



Total accessibility with maximum throw and power to spare

The ST-1600 Rotor includes a spacious vault system that makes it the premium solution for synthetic turf irrigation. With a powerful throw radius up to 50 m, the ST-1600 is field-tested and time-proven to be the most reliable gear-driven synthetic turf rotor on the market. It's designed for seamless installation and includes a construction-grade fiberglass shell for easy servicing of all components.

The riser-mounted ST-1600-HS-BR Rotor is perfect for retrofitting synthetic fields. It's also an ideal dust-control solution for horse arenas, corrals, and pastures.



ST-1600-HS-B ROTOR

The exclusive ST Infill Barrier System accommodates every field surface configuration, including infill turf, short non-infill turf, synthetic running track, and in-concrete installations.



KEY BENEFITS

- Proven isolated, grease-lubricated gear drive for consistent top performance
- Flexible arc adjustment from 40° to 360° with left and right movable stops
- Ratcheting nozzle turret for simple setup
- Corrosion- and impact-resistant body for ultimate durability
- Stainless steel and brass internal construction for long-term reliability



ST-1600 SHORT-RADIUS NOZZLE KIT: P/N 959900

OPERATING SPECIFICATIONS

- Radius: 21.3 to 50.3 m
- Flow: 5.3 to 74.2 m³/hr; 88 to 1,237 l/min
- Operating pressure range: 4.0 to 8.0 bar; 400 to 800 kPa
- Rotation speed adjustable down from 80 seconds (single 180° sweep) at 8.0 bar; 800 kPa
- Nozzle trajectory: 25°
- Nozzles 16 through 26 included
- Warranty: 5-year component warranty

ST-1600-KIT-B VAULT SYSTEM

- Vault** 4-piece, thick polymer-concrete vault designed for clean installation and simple servicing
- Quick Coupler** Quick Coupler Valve provides a convenient water source for washing down the field
- On-Off Auto Selector** Valve control functions and solenoid connections are close to the surface for easy access

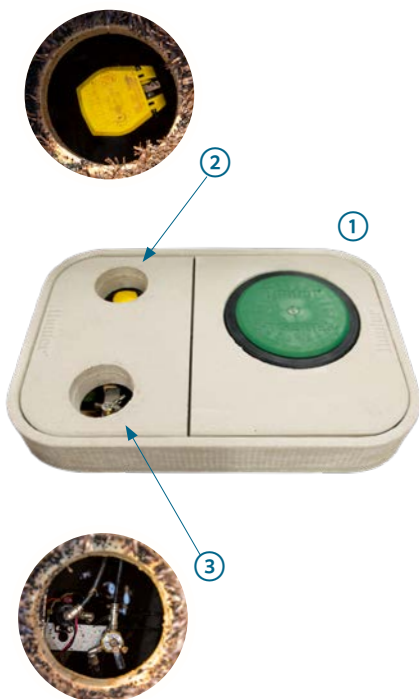

ST-1600 SHORT-RADIUS NOZZLE KIT PERFORMANCE CHART: P/N 959900

Nozzle	Pressure		Radius m	Flow		Precipitation mm/hr	
	bar	kPa		m ³ /hr	l/min	■	▲
8	4.0	400	21.3	5.3	88	23.3	26.8
	5.0	500	21.9	5.8	97	24.1	27.8
	6.0	600	22.6	6.2	103	24.4	28.1
	7.0	700	23.2	6.6	111	24.7	28.5
10	4.0	400	24.7	8.6	143	28.2	32.5
	5.0	500	25.6	9.7	161	29.5	34.0
	6.0	600	26.2	10.7	178	31.1	36.0
	7.0	700	26.8	11.6	193	32.2	37.2
12	4.0	400	28.0	12.2	204	31.1	36.0
	5.0	500	28.7	13.7	229	33.5	38.7
	6.0	600	29.3	14.9	249	34.9	40.3
	7.0	700	29.9	16.3	272	36.6	42.2
14	4.0	400	31.4	15.7	262	31.9	36.9
	5.0	500	32.0	17.8	296	34.7	40.0
	6.0	600	32.9	19.4	324	35.8	41.4
	7.0	700	33.5	21.0	350	37.4	43.2

ST-1600 NOZZLE PERFORMANCE CHART

Nozzle	Pressure		Radius m	Flow		Precipitation mm/hr	
	bar	kPa		m ³ /hr	l/min	■	▲
16	4.0	400	32.5	21.8	364	41.4	47.8
	5.0	500	35.0	24.4	406	39.8	45.9
	6.0	600	37.0	26.8	446	39.1	45.1
	7.0	700	39.0	28.9	482	38.0	43.9
	8.0	800	41.0	31.2	520	37.1	42.9
18	4.0	400	34.0	24.3	405	42.0	48.6
	5.0	500	37.0	27.1	452	39.6	45.8
	6.0	600	39.0	29.8	496	39.1	45.2
	7.0	700	40.5	32.1	535	39.1	45.2
	8.0	800	43.0	34.8	580	37.6	43.5
20 Factory-installed nozzle	4.0	400	35.0	32.7	545	53.4	61.7
	5.0	500	39.0	36.5	609	48.1	55.5
	6.0	600	43.0	40.1	668	43.4	50.1
	7.0	700	44.0	43.3	721	44.7	51.6
	8.0	800	45.0	46.4	773	45.8	52.9
22	4.0	400	36.0	38.9	649	60.1	69.4
	5.0	500	39.5	43.6	726	55.8	64.5
	6.0	600	44.0	47.7	795	49.3	56.9
	7.0	700	47.0	51.5	859	46.7	53.9
	8.0	800	48.0	55.2	920	47.9	55.3
24	4.0	400	37.0	45.9	765	67.1	77.4
	5.0	500	40.5	51.3	855	62.6	72.2
	6.0	600	45.0	56.2	937	55.5	64.1
	7.0	700	47.5	60.7	1,012	53.8	62.2
	8.0	800	48.7	65.0	1,084	54.9	63.3
26	4.0	400	38.4	53.0	883	71.8	82.9
	5.0	500	41.4	59.2	986	68.8	79.5
	6.0	600	46.0	64.6	1,077	61.0	70.4
	7.0	700	48.7	69.7	1,162	58.6	67.7
	8.0	800	50.3	74.2	1,237	58.7	67.8

Notes:

All precipitation rates are calculated for 180° operation. For the precipitation rate of a 360° sprinkler, divide by 2. All radius measurements are taken at standard rotation speeds. Slowing rotation to minimum rotation speed will add 3+ metres to the radius.

ST-1700-V-B Rotor



No-Dig Servicing and Easy Installation For Synthetic Turf Irrigation Management

The long-range ST-1700-V Synthetic Turf Rotor offers high-performance irrigation from the field perimeter while integrating Valve-in-Head (VIH) capabilities and a Total-Top-Service (TTS) design to simplify installation and maintenance.

The rotor's heavy-duty gear drive provides a powerful throw up to 48 m, and the spacious flange compartment accommodates full-sized, waterproof splice connectors with extra space to house a decoder for two-wire control system applications.



VIH configuration makes installation fast and easy



ST-1700-V-B ROTOR

Includes all the features and benefits of the popular ST-1600 Rotor



Infill Barrier System Rubber Cover Kit (P/N ST-IBS-1700) designed for seamless integration with the field



ST-1700-V-B NOZZLE PERFORMANCE CHART

Nozzle	Pressure		Radius m	Flow		Precipitation mm/hr	
	bar	kPa		m ³ /hr	l/min	■	▲
16	4.0	400	32.0	21.0	350	41.0	47.3
	5.0	500	35.0	22.7	379	37.1	42.8
	6.0	600	37.0	25.9	432	37.8	43.7
	7.0	700	38.5	28.1	469	38.0	43.9
	8.0	800	40.0	30.4	508	38.1	43.9
18	4.0	400	34.0	24.3	405	42.0	48.5
	5.0	500	36.5	26.1	435	39.2	45.3
	6.0	600	38.5	28.8	481	38.9	44.9
	7.0	700	40.0	31.1	519	38.9	44.9
	8.0	800	42.0	33.8	564	38.3	44.3
20	4.0	400	35.0	30.4	508	49.7	57.4
	5.0	500	39.0	34.3	572	45.1	52.0
	6.0	600	41.0	37.2	621	44.3	51.1
	7.0	700	43.0	40.9	681	44.2	51.0
	8.0	800	45.0	44.0	733	43.4	50.1
22	4.0	400	35.5	34.9	582	55.4	63.9
	5.0	500	39.0	39.5	659	51.9	60.0
	6.0	600	43.0	42.9	715	46.4	53.6
	7.0	700	45.5	46.8	780	45.2	52.2
	8.0	800	47.0	50.4	841	45.7	52.7
24	4.0	400	37.0	40.2	671	58.8	67.9
	5.0	500	40.5	45.6	761	55.6	64.2
	6.0	600	44.0	50.4	840	52.1	60.1
	7.0	700	47.0	54.5	908	49.3	57.0
	8.0	800	48.0	58.8	980	51.0	58.9

Notes:

All precipitation rates are calculated for 180° operation. For the precipitation rate of a 360° sprinkler, divide by 2. All radius measurements are taken at standard rotation speeds. Slowing rotation to minimum rotation speed will add 3+ metres to the radius.

KEY BENEFITS

- Nozzle choices: 5
- Standard nozzle: 20
- Nozzle range: 16 to 24
- Nozzle trajectory: 25°
- Total-Top-Service (TTS) design provides convenient, no-dig servicing
- Valve-in-Head (VIH) configuration simplifies installation
- Isolated, grease-lubricated gear drive
- Factory-installed rubber logo cap
- Arc adjustment: movable stops for left/right arc adjustment
- Ratcheting nozzle turret

OPERATING SPECIFICATIONS

- Radius: 32 to 48 m
- Flow: 21.0 to 58.8 m³/hr; 350 to 980 l/min
- Operating pressure range: 4.0 to 8.0 bar; 400 to 800 kPa
- Arc setting: 40° to non-reversing 360°
- Rotation speed adjustable down from 80 seconds (single 180° sweep) at 6.0 bar; 600 kPa
- Precipitation rate: 45 mm/hr approximately
- Warranty: 5-year component warranty

USER-INSTALLED OPTIONS

- Infill Barrier System Rubber Cover Kit: P/N ST-IBS-1700
- Short-Radius Nozzle Kit: P/N 959900
- Optional high-flow swing joint, 3" (80 mm) male inlet to 2" (50 mm) male outlet, 30 cm length: P/N HSJ-5-6-E-3-12

OPTIONAL SERVICING TOOLS

Model	Description
10000100SP	ST-1700-V-B Valve Tool - Installation/Removal of Inlet Valve
251000SP	Snap Ring Tool
517600SP	ST-1600/ST-1700 Tool - Gear Drive Installation/Removal

Heavy-duty, internal gear drive provides years of reliable operation



TTS design provides convenient, no-dig servicing without the need to cut into the synthetic surface



Helping our customers succeed is what drives us. While our passion for innovation and engineering is built into everything we do, it is our commitment to exceptional support that we hope will keep you in the Hunter family of customers for years to come.

A white, handwritten signature of Gregory R. Hunter is centered on the page.

Gregory R. Hunter, CEO of Hunter Industries

A white, handwritten signature of Denise Mullikin is centered on the page.

Denise Mullikin, President, Landscape Irrigation and Outdoor Lighting

Website hunterirrigation.com | **Customer Support** +1-760-752-6037