

Hunter®



ACCESSORIES PRICELIST

ROTORS SPRAYS VALVES CONTROLLERS SENSORS CENTRAL CONTROLS ACCESSORIES

10

EFFECTIVE NOVEMBER 2009

Accessories

Item	Description	Catalog No.	Price
①	Turf Plug Cutter (I-44/45)	150500	\$15.00
②	Rotor Pitot Gauge	280100	\$60.00
③	Rotor Pressure Gauge (PGP only)	129900	\$45.00
④	Nozzle Insertion Collar	123200	\$0.75
⑤	Riser Service Tool (I-60)	279100	\$125.00
⑥	Hand Pump-Water Extraction	460302	\$70.00

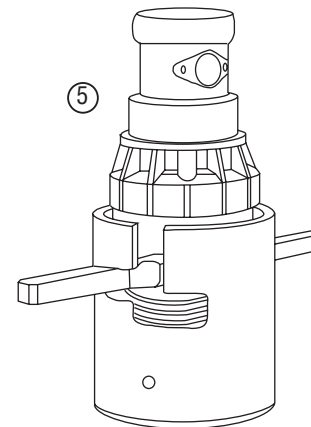
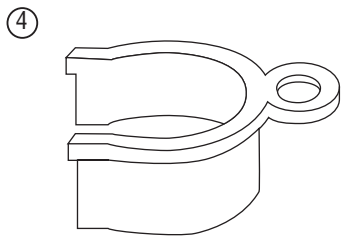
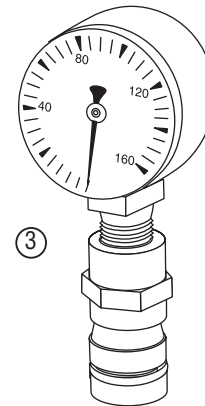
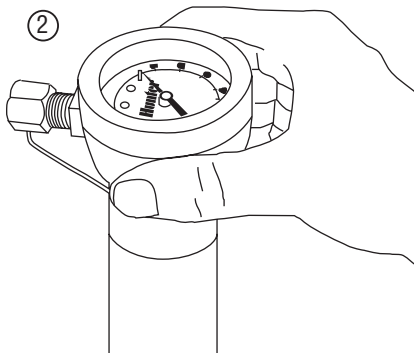
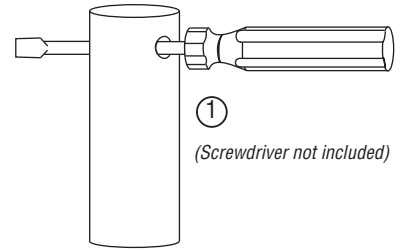

Accessories

Item	Description	Catalog No.	Price
①	Wrench	172000	\$0.50
②	Valve Pressure Gauge	S16538	\$125.00
③	Sub-Surface Stabilizer Flange (1-25/1-35/1-40)	222700	\$5.00

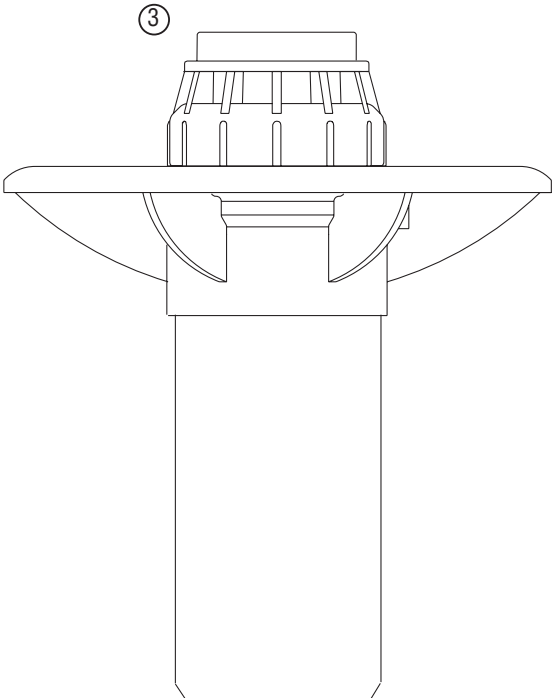
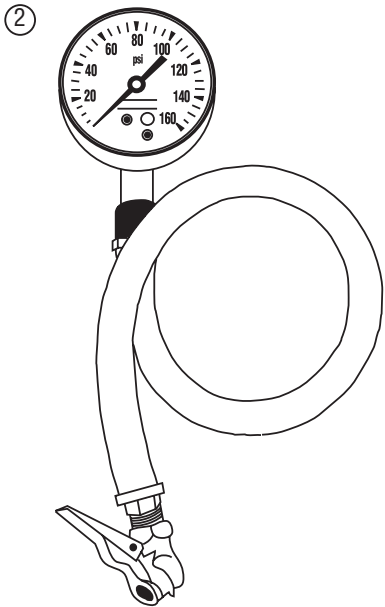
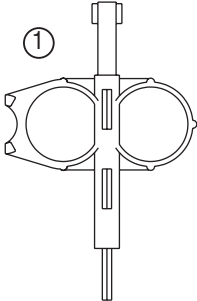

STATEMENT OF WARRANTY

Hunter Industries Incorporated (“Hunter”) warrants the following products to be free of defects in materials or workmanship under normal use for a period of two (2) years from the original date of manufacture: PGP-ADJ®, PGJ, PS, PS Ultra, SRS, Pro-Spray®, Spray Nozzles, PCN, PCB, AFB, HPV, PGV family, Pro-ASV, SRV, SRC, XC family, Pro-C family, SRR, ROAM, SVC, WVP, WVS, MP Rotator, PLD, PACZ, PCZ, AVB, PSR, HCV, SJ, HFT family, SBE family, RZWS, ET System, and Solar Sync. Hunter warrants the following products to be free of defects in materials or workmanship under normal use for a period of three (3) years from the original date of manufacture: PGP Ultra family. Hunter warrants the following products to be free of defects in materials or workmanship under normal use for a period of one (1) year from the original date of manufacture: SRM family, Micro Sprays, and Stream Drippers. Hunter warrants the following products to be free of defects in materials or workmanship under normal use for a period of five (5) years from the original date of manufacture: Institutional Spray, G-Spray, MPR-40 family, I-20, I-25, I-35, I-40, I-60 and I-90 families, ICC, I-CORE, and ACC controller families, ICD Decoder Products, ICR Remotes, IMMS™ Central Control Products, “Clik” Sensors, HQ, ICV plastic and IBV brass valves, ICZ and PLD tubing. [If a defect in a Hunter product is discovered during the applicable warranty period, Hunter will repair or replace, at its option, the product or the defective part.] This warranty does not extend to repairs, adjustments, or replacement of a Hunter product or part that results from misuse, negligence, alteration, modification, tampering, or improper installation and/or maintenance of the product. This warranty extends only to the original installer of the Hunter product. If a defect arises in a Hunter product or part during the warranty period, you should contact your local Hunter Authorized Distributor.

HUNTER’S OBLIGATION TO REPAIR OR REPLACE ITS PRODUCTS AS SET FORTH ABOVE IS THE SOLE AND EXCLUSIVE WARRANTY SET FORTH BY HUNTER. THERE ARE NO OTHER WARRANTIES, EXPRESSED OR IMPLIED, INCLUDING WARRANTIES OF MERCHANTABILITY AND FITNESS FOR A PARTICULAR PURPOSE. HUNTER WILL NOT BE LIABLE TO ANY PARTY IN STRICT LIABILITY, TORT, CONTRACT, OR ANY OTHER MANNER FOR DAMAGES CAUSED OR CLAIMED TO BE CAUSED AS A RESULT OF ANY DESIGN OR DEFECT IN HUNTER’S PRODUCTS, OR FOR ANY SPECIAL, INCIDENTAL OR CONSEQUENTIAL DAMAGES OF ANY NATURE.

If you have any questions concerning the warranty or its application, please write to:
Marketing Department, Hunter Industries Incorporated,
1940 Diamond Street, San Marcos, CA 92078, U.S.A.

ASAE CERTIFICATION STATEMENT

Hunter Industries Incorporated certifies that pressure, flow rate, and radius data for these products were determined and listed in accordance with ASAE Standard S398.1, Procedure for Sprinkler Testing and Performance Reporting, and are representative of performance of production sprinklers at the time of publication. Actual product performance may differ from the published specifications due to normal manufacturing variations and sample selection. All other specifications are solely the recommendation of Hunter Industries Incorporated.

U.S.A. HEADQUARTERS

1940 Diamond Street
San Marcos, California 92078
Tel: (1) 760-744-5240
Fax: (1) 760-744-7461
Technical Service: (1) 800-733-2823

INTERNET

www.hunterindustries.com
e-mail: information@hunterindustries.com

WORLDWIDE SALES OFFICES:

AUSTRALIA

8 The Parade West
Kent Town, South Australia 5067
TEL: (61) 8-8363-3599
FAX: (61) 8-8363-3687

EUROPE

Avda. Diagonal 523, 5° - 2°
Edificio Atalaya
08029 Barcelona, Spain
Tel: (34) 9-34-94-88-81
Fax: (34) 9-34-19-76-76

MIDDLE EAST

P.O. Box 211303
Amman, 11121 Jordan
Tel: (962) 6-515-2882
Fax: (962) 6-515-2992

CHINA

B1618, Huibin Office Bldg.
No. 8, Beichen Dong Street
Beijing 100101 China
Tel/Fax: (86) 10-84975146
Mobile: (86) 13901321516

MANUFACTURING:

MEXICO

Calle Nordika #8615
Parque Industrial Nordika
Tijuana, B.C. Mexico C.P. 22709
Tel: (52) 664-903-1300
Fax: (52) 664-903-8078