

ET System

**Evapotranspiration Sensor and
Module for Hunter Controllers
with SmartPort®**

Owner's Manual and Programming Instructions

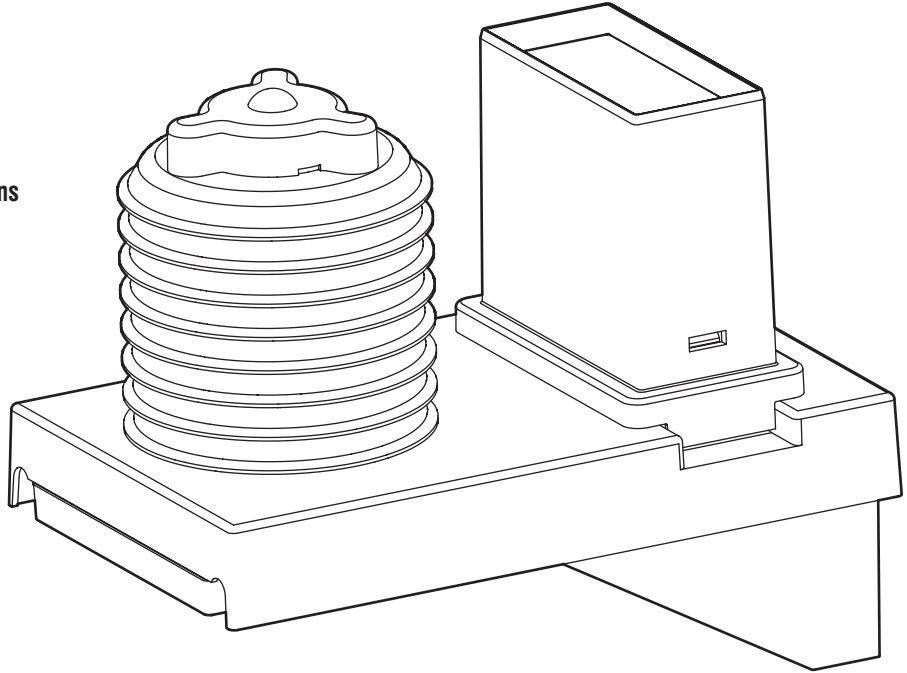

Hunter®

TABLE OF CONTENTS

| | | | |
|--|----|------------------------------------|----|
| Introduction | 1 | Set Time/Date | 15 |
| ET System Components..... | 3 | Set Daylight Savings | 16 |
| System Overview and ET System Operation | 3 | Plant Type | 16 |
| Installing the ET Sensor | 4 | Maturity | 17 |
| Additional Tools and Materials | 4 | Type | 17 |
| Choose the Location | 4 | Variety..... | 17 |
| ET Sensor Wiring..... | 5 | Site Info | 19 |
| Prevailing Wind Compensation | 5 | Slope | 19 |
| Metal Fence Pole..... | 6 | Soil | 19 |
| Wooden Post | 6 | Sun | 20 |
| Wall or Eave | 6 | Sprinkler Type..... | 20 |
| Installing the ET Module | 7 | Precip | 20 |
| ET Module Wiring | 7 | Water Days | 21 |
| SRC or SRC <i>Plus</i> Controller Connection | 8 | Daily Start Time | 22 |
| Pro-C Controller Connection | 8 | WiltGard™ | 22 |
| ICC Controller Connection | 8 | Rain Setting | 24 |
| Remote Control Connection..... | 9 | ET Setup | 25 |
| ACC Controller Connection | 9 | Automatic | 26 |
| Test..... | 11 | Watering History..... | 27 |
| Maintaining the ET Sensor | 11 | View Sensor Date..... | 29 |
| Programming and Operating the ET Module | 12 | Reset | 29 |
| General Operating Tips | 12 | Troubleshooting | 30 |
| Setup Overview..... | 13 | Specifications..... | 34 |
| Global % Setting | 13 | ET System Compatibility List | 34 |
| Initial Soil Deficit..... | 13 | Dimensions | 34 |
| International Users – Metric Setting | 13 | FCC Notice | 34 |
| Controller Type | 14 | | |
| Prepare the Controller..... | 14 | | |

INTRODUCTION

The Hunter ET System allows an irrigation program to be created automatically, based on local climate conditions. The program is then operated via a compatible irrigation controller's Program A (except ACC controllers, see page 14) and runs automatically, on water days and at start times set by the system operator. Compatible controllers are Hunter Models SRC/SRC *Plus*, Pro-C, ICC, and ACC with SmartPort® technology.

ET System uses sensors to determine the local "evapotranspiration" (ET) rate of turf and plants. This is a formula which calculates how much water the plants have lost, or consumed, due to local atmospheric conditions. Each ET System can be customized by station (or "zone") for specific plant, soil, and sprinkler types.

The result is a new, water-efficient irrigation program every water day, based on local weather conditions.

Once installed, the ET-controlled zones are programmed from the ET Module, rather than the controller itself. The ET Module will display the new program data for the climate-based irrigation.

The ET System allows manual station starts from the controller, and will also permit connection of an ICR or SRR remote control receiver.

This product is intended for turf and landscaping applications only, not intended for agricultural or scientific use.

Use the ET System Worksheet. One is included with each ET System, and this can also be downloaded free of charge from the Hunter Industries web site (www.hunterindustries.com at the ET System product page). The ET System Worksheet will help you organize and record your station settings. This will also help to determine and track any adjustments you may make to the watering settings. If you need Technical Support, the Hunter technician will also need this information.

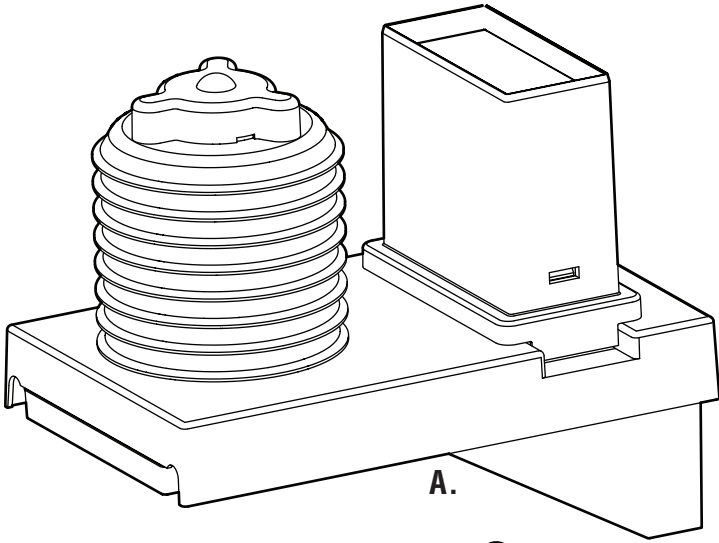

A.

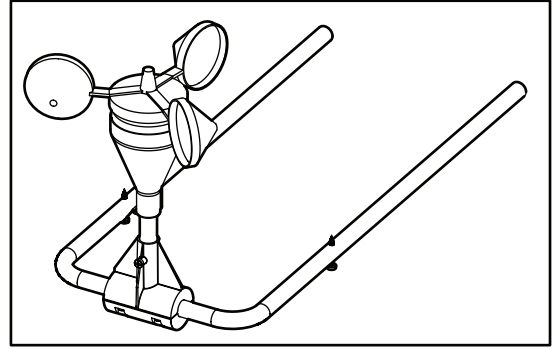

C.

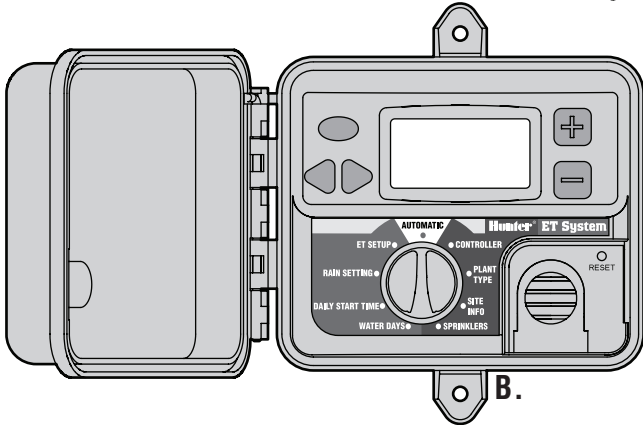

B.

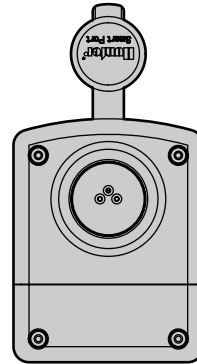

D.

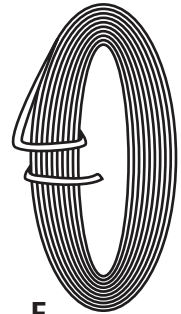

E.

ET SYSTEM COMPONENTS.....

ET System has two major components, and one optional accessory. All ET System components are low voltage (24 VAC or less).

A. ET Sensor

Sensor platform wired to the ET Module, which senses local conditions. For external mounting up to 100 ft/33m from the Module. Pole adapters included (requires other hardware for various mounting options).

B. ET Module

Electronic control and user interface for the ET System.

C. ET Wind (Optional)

Optional anemometer which senses wind speed. Provides more sensitive ET measurement, especially in arid climates.

D. ET/ACC Adapter (Included)

For connection with ACC series controllers. The adapter is not required for use with Hunter ICC, Pro-C, and SRC family controllers.

E. ET Wire

100' (33mm) two-conductor direct burial for connection to ET Sensor

SYSTEM OVERVIEW AND ET SYSTEM OPERATION.....

The ET System can be simply and easily installed with any Hunter SmartPort®-equipped irrigation controller. The System consists of the ET Sensor, installed in an area typical of the irrigated plants, and the ET Module interface enclosure, installed next to the irrigation controller.

The ET Sensor measures solar radiation, air temperature, and relative humidity, and calculates the daily Evapotranspiration factor (ET) for the irrigation zones. This represents the amount of water lost by the plants to local climatic conditions, which needs to be replaced by irrigation.

The optional ET Wind sensor will add evapotranspiration loss due to wind, along with automatic wind shutdown capability.

The ET Sensor also includes a Rain Gauge, which measures rainfall in either hundredths of an inch, or in millimeters.

Rainfall will stop automatic ET irrigation that may be in progress. A percentage of the rainfall itself will be added to the soil and subtracted automatically from the automatic irrigation, to prevent waste.

The ET Module receives the data from the ET Sensor, and applies it to the individual zones of irrigation. The ET Module has settings to customize each zone's plant, soil, and sprinkler types, so that ET data can be applied proportionately for each unique irrigation requirement.

The ET Module is wired into the controller's SmartPort and creates irrigation run times to only replace the amount of water the plants have lost.

ET Module works by running stations through the local controller. It will clear Program A in the local controller (except in ACC controllers), and it will then run the ET run times with manual commands. Program A is no longer available for "traditional" irrigation scheduling.

How ET System Decides to Water: Using the local ET Sensor readings and the ET Module's database of station information, ET System predicts the Management Allowable Depletion of water (MAD) available to each plant type.

Each day, ET System looks at the current depletion level, ET rate, plant type (crop coefficient and root zone), and whether the next day is an allowable watering day. The decision to start a specific station is also based upon a minimum irrigation amount, to prevent shallow watering. Deeper watering events encourage healthy root systems and plant growth. The calculation for minimum sprinkler runtime is based upon the soil type and capacity, where typically the MAD is above 30-50%. For the worst-case scenario, sandy soil with spray heads, the minimum runtime would then be approximately 7 minutes.

INSTALLING THE ET SENSOR.....

Additional Tools and Materials

The ET system is supplied with 100'/33m of wire for connection of the ET Sensor. This wire has been specially tested for ET installations and is approved to 100'/33m max.

If any other wire is to be used, Hunter recommends 2 x 18 AWG/1mm wire rated for direct burial, color-coded or otherwise marked to identify the separate conductors. The ET signal is a low-voltage DC and the conductors must be distinguished from each other to maintain polarity. Either stranded or solid wire is acceptable (stranded is more flexible and resists breakage). The ET signal is rated to 100'/33m max and is not tested or approved to any greater distance.

Choose the Location

ET Sensor should be placed in an area representative of the plants it is designed to irrigate.

The ET Sensor should be **post or pole-mounted in a full-sun turf grass area, approximately 6 ft./2m above the grass, with approximately 6 ft./2m of turf grass surrounding it on all sides.** The ET Sensor weighs approximately 6 lbs./2.5kg.

This may not always be practical, so choose the actual location according to the following guidelines:

- ET Sensor must be mounted within 100 ft./33m of the ET Module and the controller.
- Avoid positioning ET Sensor over large areas of concrete, asphalt, roof tile, or shingles. These surfaces will cause the sensors to read much higher levels of ET than plants.
- Choose a sunny location between 6 and 20 feet (2 and 7m) above the ground.
- Do not mount the sensor where it will be hit by sprinkler spray or other irrigation!

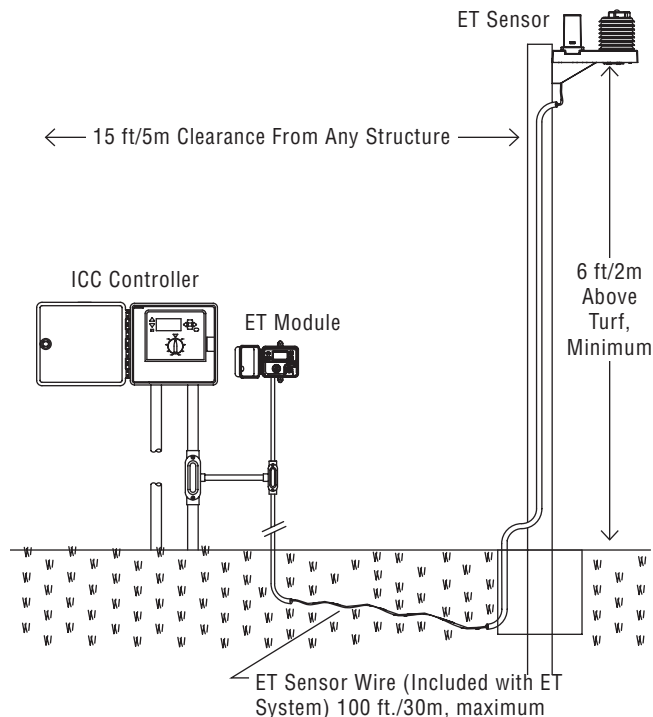

- Do not mount the ET Sensor under a ledge or overhang, and avoid placing it directly under tree canopies. **ET Sensor needs un-blocked sun and rain to function correctly!**
- Do not mount the ET Sensor within falling distance of power lines!** High voltage shocks can injure and kill.

- g) Position the ET Sensor where it can be reached for occasional service. The rain gauge should be checked and cleaned once a month during the warmer months, to ensure that it is free of debris.
- h) Avoid mounting sensor near any high intensity light, heat or infrared sources as this may add excess ET amounts over time.

The ET Sensor is designed to adapt to steel fence poles (mounting adapters included, requires 2 x 2"/50mm² U-bolts), 4x4"/100mm² (or larger) posts, or eaves or walls.

Metal poles or weather-treated wooden posts are preferred, since ET measurements will be somewhat less accurate if the sensor is wall or eave-mounted.

ET Sensor Wiring

Before mounting the ET Sensor, connect the wires to the terminal strip. This operation is much easier on the ground, prior to mounting the sensor.

Locate the wiring compartment cover on the bottom of the ET Sensor. This is a trap door, secured with 2 screws. Remove the wiring compartment door screws and set in a safe place, and remove the wiring compartment door.

Locate the screw terminal strip. Connect the two long conductors (green and black) to the appropriately labeled terminals.

If an ET Wind Sensor is to be installed, this is also the time to connect the wires.

Prevailing Wind Compensation

If ET Wind will not be connected, a factor for average prevailing

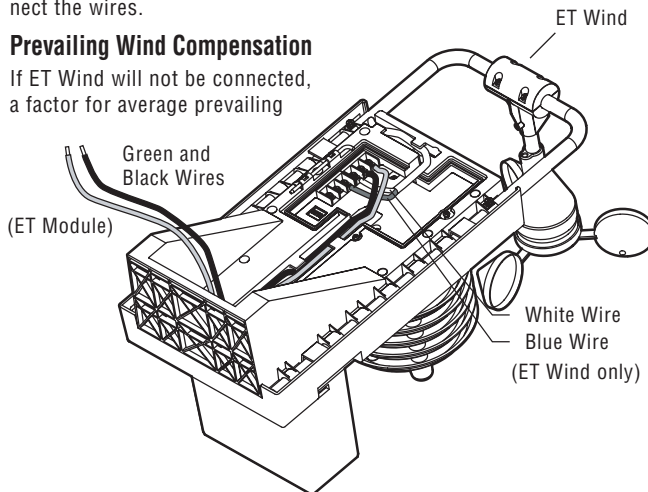

Average Wind Factor Settings. Switch #4 is not used, and position does not matter.

| Avg. Wind | 1mph | 2mph | 3mph | 4mph | 5mph | 6mph | 7mph |
|--------------------|---------------|---------------|---------------|---------------|-------------|---------------|----------------|
| DIP setting | 1.6kph | 3.2kph | 4.8kph | 6.4kph | 8kph | 9.6kph | 11.2kph |
| SW 1 | On | Off | On | Off | Off | Off | On |
| SW 2 | Off | On | On | Off | Off | On | On |
| SW 3 | Off | Off | Off | On | Off | On | On |
| ON | | | | | | | |
| OFF | | | | | | | |
| | 1 2 3 4 | 1 2 3 4 | 1 2 3 4 | 1 2 3 4 | 1 2 3 4 | 1 2 3 4 | 1 2 3 4 |

winds in the installation area can be entered while the wiring door is removed. The factory default setting is 5 mph (8 kph). With the wiring cover removed, a DIP switch is visible allowing other prevailing average wind speeds to be set, according to the Table 1 (note that Switch 4 is not used).

If the optional ET Wind sensor is installed, mount the ET Wind sensor according to its instructions, and connect the blue and white conductors from the ET Sensor to the appropriately labeled terminals and secure their screws. Do not reverse the blue and white wire connections from ET Wind... connect as shown!

Replace the wiring compartment door and secure with the screws.

Metal Fence Pole

Steel adapters are supplied for most popular sizes of galvanized steel fence posts, 2" diameter and smaller.

Additional materials (not supplied): 2 x 2" galvanized or stainless steel U-bolts, 3" long or greater

4 nuts and washers for U-bolts

Bag of concrete

If pole is new construction for specific purpose of mounting ET Sensor, dig approximately 12" x 12" hole and fill with approximately one 90 lb. bag of concrete, or place as required by local code. Insert pole, check with level and straighten, and brace until concrete is firmly set.

Insert U-bolts around pole through steel pole adapters, and through mating holes in ET Sensor back plane. Add washers, thread nuts onto U-bolt, and tighten. Do not overtighten.

Route ET Sensor wire to ground surface or burial trench, and run back to ET Module.

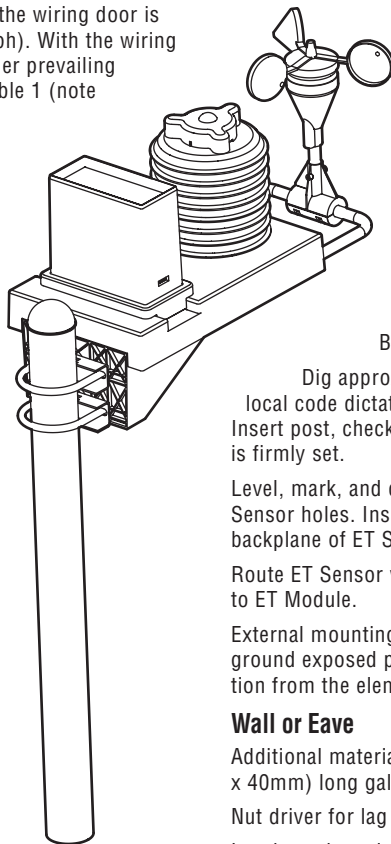

External mounting in outdoor low voltage conduit (for the above-ground exposed portion of the wire run) is recommended for protection from the elements.

Wooden Post

Additional materials (not supplied): 4x4"/100mm² pressure-treated, outdoor, direct-burial grade 4x4"/100mm² or larger post.

100mm x 6mm dia. x 3,8cm long galvanized or stainless steel lag bolts and washers

Nut driver for lag bolts

Bag of concrete

Dig approximately 12" x 12"/30cm x 30cm hole (or greater, as local code dictates) and fill with approximately one bag of concrete. Insert post, check with level and straighten, and brace until concrete is firmly set.

Level, mark, and drill pilot holes for 4 lag screws through back of ET Sensor holes. Insert lag bolts and washers through mounting hole in backplane of ET Sensor and tighten. Do not overtighten.

Route ET Sensor wire to ground surface or burial trench, and run back to ET Module.

External mounting in outdoor low voltage conduit (for the above-ground exposed portion of the wire run) is recommended for protection from the elements.

Wall or Eave

Additional materials (not supplied): 4 x 1/4" dia. x 1.5" (100mm x 6mm x 40mm) long galvanized or stainless steel lag bolts and washers.

Nut driver for lag bolts.

Level, mark, and drill pilot holes for 4 lag screws through back of ET Sensor holes. Insert lag bolts and washers through mounting hole in backplane of ET Sensor and tighten. Do not overtighten.

Route ET Sensor wire to ground surface or burial trench, and run back

to ET Module. External mounting in outdoor low voltage conduit (for the above-ground exposed portion of the wire run) is recommended for protection from the elements.

In all cases, ensure that any exposed wire loop from the ET Sensor to

INSTALLING THE ET MODULE

immediately next (6 ft./2m) to the Hunter SmartPort-equipped irrigation controller (including models SRC, Pro-C, ICC, and ACC). The ET Module is low-voltage only and does not require a separate high-voltage power connection.

The ET Module is connected to the ET Sensor via the two conductor sheathed wires supplied with the ET System (up to 100 ft./30m away), and then wired into the SmartPort wiring terminals inside the controller.

To wall mount the ET Module, choose a location within 6 ft./2m of the controller. Avoid direct sunlight when possible (to enhance visibility of the LCD display). Verify that the wallboard construction is of sufficient strength to securely mount the small, lightweight enclosure.

The 6-conductor umbilical cord extends through the shielded hole in the bottom of the enclosure. Verify that it remains clear and accessible when securing the enclosure to the wall.

Use two anchors or self-tapping screws of minimum #12 (5.5mm) diameter to secure the ET Module enclosure to the wall.

Turn off AC power to the irrigation controller, before connecting the ET Module to the controller! The ET System receives its power from the SmartPort connection to the Hunter controller. Do not connect the ET Module to the controller while AC power is turned on.

ET Module Wiring

The 6-conductor umbilical cord from the ET Module is color-coded to simplify connections.

Do NOT connect 110/230V high-voltage power to the ET System!

Make all wiring connections with approved butt splices or wire nuts for the ET wire, and place the splices in a suitable junction box. Conduit is recommended for both indoor and outdoor installations.

the wire routing conduit does not swing freely in the wind, as this will shorten its life.

The ET Module is designed to be wall-mounted, either in or outdoor,

Install CR2032 backup battery for date/time backup in event of power failure (battery included with mounting hardware). Battery must be installed with + visible, facing toward the installer.

If connecting the ET System to an ACC series controller, see ACC section for special installation instructions.

ICC, Pro-C, and SRC controllers (ACC special instructions in next section): Connect the supplied wires from the ET Module to the ET

Install CR2032 lithium battery (included)
under cover for time/date backup.

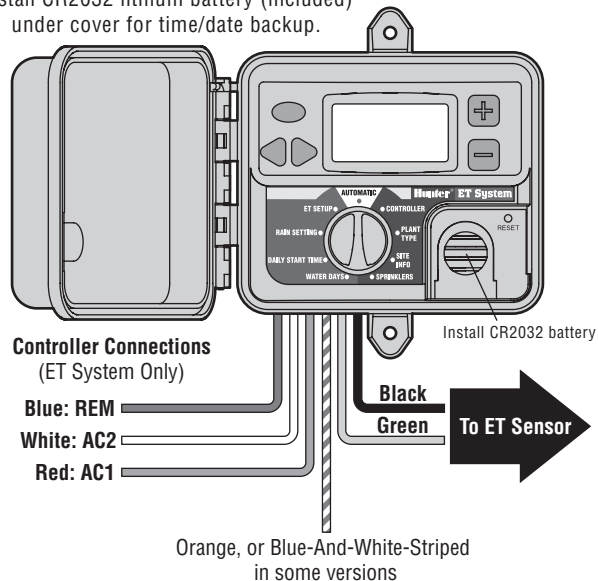

Sensor with appropriately sized butt splices or wire nuts. These two wires may be extended up to 100 ft./30m to reach the sensor.

SRC or SRC Plus Controller Connection

If no wireless remote control receiver will be installed, the Orange wire (or Blue-And-White-Striped wire in some versions) from the ET Module is not used.

Connect the red wire from the ET Module to the bottom left of the two terminals on the power module labeled "24VAC" (or just AC, on older units).

Connect the white wire from the ET Module to the second to the right of the two terminals on the power module labeled "24VAC" (or just AC, on older units)..

Connect the blue wire from the ET Module to the terminal in the controller labeled "R".

If no wireless remote control receiver will be installed, the blue-and-white striped wire from the ET Module is not used.

Pro-C Controller Connection

Connect the red wire from the ET Module to the terminal in the controller labeled AC1.

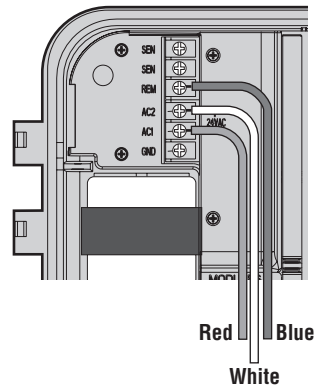
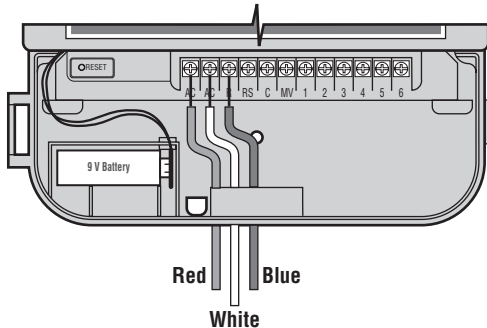

Connect the white wire from the ET Module to the terminal in the controller labeled AC2.

Connect the blue wire from the ET Module to the terminal in the controller labeled REM.

ICC Controller Connection

Connect the red wire from the ET Module to the bottommost of the terminals on the power module labeled "AC".

Connect the white wire from the ET Module to the upper of the two terminals on the power module labeled "AC".

Connect the blue wire from the ET Module to the terminal in the controller labeled REM.

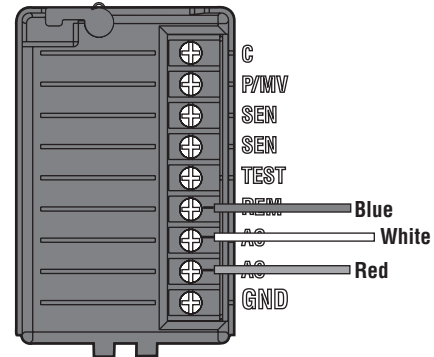

Remote Control Connection

If a remote control (either Hunter ICR or SRR) receiver is to be connected, connect the Orange wire (or Blue-And-White-Striped wire in some versions) from the ET Module, to the blue ICR/SRR receiver wire. The SmartPort wiring that connects ET Module to the controller will complete the connection for the remote receiver.

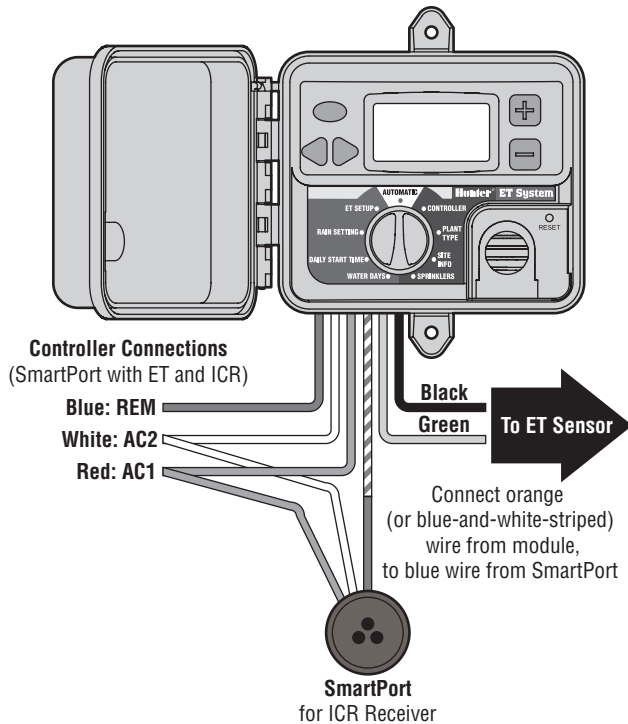

ACC Controller Connection

The ET System is shipped with a special adapter for use with the ACC series of controllers.

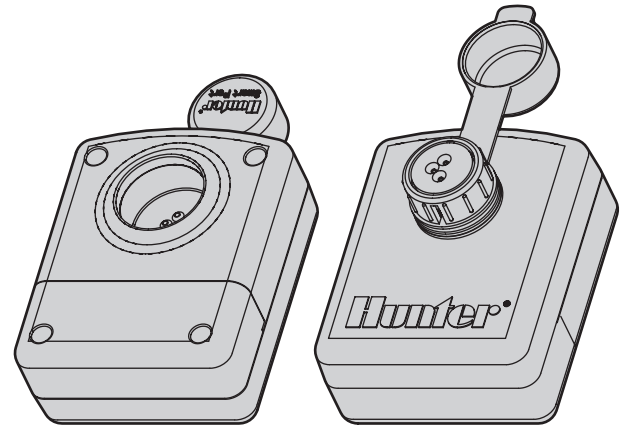

The ACC controllers have an integrated SmartPort for remote receivers (such as the Hunter ICR remote control) on the side of the cabinet in the metal cabinet configurations, and inside the pedestal in the plastic pedestal configurations.

All ET System connections are made within the enclosed ET/ACC adapter, which is then plugged into the SmartPort. The adapter allows both ICR remote receivers and the ET System to be connected to the ACC controller at the same time.

When installing ET System with an ACC controller, the ET Sensor connections are also made at the terminal strip inside the adapter, NOT to the ET Module cable directly. This is only true for ACC connections.

Installation

Remove the screws holding the terminal strip cover on ET/ACC adapter.

Connect the red, white, and blue wires from the ET Module (in that order) from left to right, on the first three terminals, as shown.

Connect the Orange wire, (or Blue-And-White-Striped wire in some versions) from the Module to the terminal as marked.

Twist the ends of the green wires from the ET Sensor and the ET Module together, and connect them together to the terminal as marked.

Twist the ends of the black wires from the ET Sensor and the ET Module together, and connect them together to the last terminal as marked.

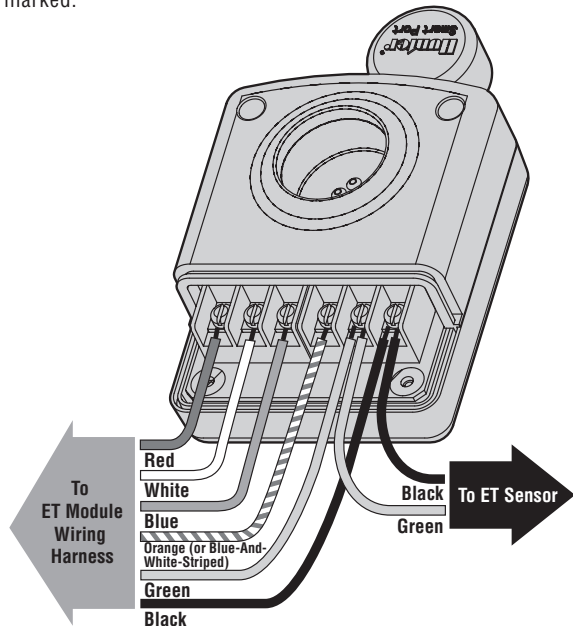

Plug the male pin side of the ET/ACC Adapter into the SmartPort receptacle on the ACC controller. ET connections are now made.

To use an ICR receiver with the ACC through the adapter, it is only necessary to plug the ICR receiver into the receptacle on the adapter, and issue commands normally.

If ICR commands are sent while ET System is irrigating automatically, and other programs are already running, it is possible that the ICR command will be ignored (if it violates the ACC maximum of 6 simultaneous stations). Likewise, if 6 events are already running in the ACC when the ET Start Time is reached, the ET events may be missed. Avoid overlapping the ET Start Time with multiple stations.

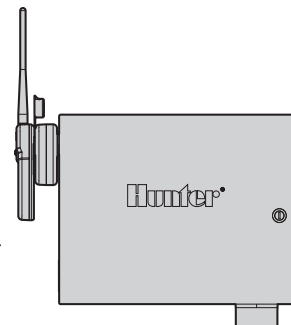

Leave enough slack in all wires to allow for expansion and contraction in temperature extremes. Secure the wire splice points to the inside of the junction box or controller, to create a strain relief.

Reapply AC power to the irrigation controller, and observe the display in the ET Module. The display should illuminate and show a welcoming screen, followed by information about the ET System.

The ET System will sense rain and freezing automatically with its own sensors, and will terminate irrigation when necessary. If this occurs, the display will show "RAIN PAUSE" or "FREEZE PAUSE".

ET System will shutdown irrigation when the temperature drops to 37°F/2.7°C. This is not programmable. Temperature shutdowns are a "pause" mode, and the system will resume watering when the temperature rises back above the shutdown amount.

If existing Clik sensors are removed, the Clik sensor inputs should have the original jumper replaced, or the sensor connection should be jumpered with a short piece of wire.

If ET WIND is connected, ET System will also detect windy conditions and shutdown automatically at preset wind levels. If this occurs, the display will show “WIND PAUSE”.

The ET Wind will shutdown irrigation when the hourly average exceeds 15 mph/24kph. This is not programmable. Wind shutdowns are a “pause” mode, and the system will resume watering when the average wind speed falls below 15 mph/24kph again.

The Sensor Bypass switch on Hunter controllers will have no effect on the ET System, or any of its Pause modes. This switch only affects external “Clik” sensors for other programs.

Installing other sensors to the controller.

The ET Sensors can stop ET-based irrigation, which is run through controller program A (except ACC controllers).

ET Sensors will NOT stop irrigation running in the controller’s B, C, or other programs.

Hunter Industries model Mini-Clik and Rain-Clik, or other sensors, can be used to stop irrigation in programs B, C, etc. and are required if those programs are used, and need to stop watering on sensor input.

The ET System does not sense flow, but may not perform correctly with Flow-Clik installations, unless the Flow-Clik is wired into the common ground to the valve connections (instead of to the controller’s sensor input). Contact Hunter Technical Services if it is necessary to use a Flow-Clik together with the ET System.

Troubleshooting: If the ET Module screen does not illuminate, check all wiring connections. Verify that the red wire from the ET Module goes to AC1, and that the white wire goes to AC2, in a Pro-C controller.

In the SRC controllers, the red wire is the left-most of the two AC connections.

In the ICC controller, the red wire must be the bottommost of the two AC connections.

Warning: The use of toners and line voltage testers on field wiring may damage the ET System if it is connected to the controller. It does not matter if the power is off to the controller. If any device is connected

to the valve wiring which produces voltage, the ET System must be physically disconnected from the host controller.

Sensor Fault: If the ET Module display shows Sensor Fault, check connection between ET Module and ET Sensor (green and black wires or equivalents). Solid conductor wire is prone to breakage from rough handling. If wires appear correctly installed and Sensor Fault persists, check the Sensor wiring with a DC voltmeter – the voltage reading at the black and green terminals on the sensor should be between 9 to 15VDC.

Test: The ET Module can run a test with the host controller to check the SmartPort wiring from ET System to the controller. **This will cause Station 1 to run for up to two minutes if successful.**

Press and hold the recessed Reset button with a ballpoint pen tip or similar item.

Press the left 3 buttons on the ET Module (STA plus left and right arrows) at once, and hold them.

Release the Reset button.

Release the left 3 buttons.

This should cause Station 1 on the controller to activate for approximately 2 minutes.

The test will be visible in the ET Module display.

If the test is successful, Station 1 will also appear active in the controller display. This verifies that the SmartPort wiring connection from the ET Module to the controller is correct.

If station does not activate in controller display (but appears in ET Module), check SmartPort wiring, in particular the red, white and blue wire connections.

MAINTAINING THE ET SENSOR

The ET Sensor is designed for outdoor use, but must be kept clean to function correctly. Wiping the platform and sensors down with a clean cloth every 30 days is recommended.

Do not use harsh chemicals or abrasives, particularly on the clear plastic solar radiation lens. It is very important that this sensor be kept clean and dust-free to record sunlight accurately.

The rain gauge may gather dust and debris, and should also be cleaned out every 30 days.

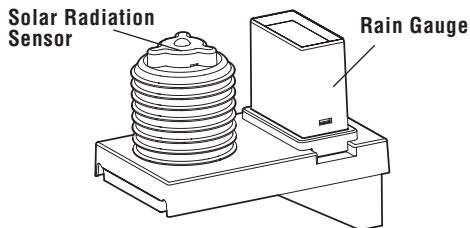

PROGRAMMING AND OPERATING THE ET MODULE.....

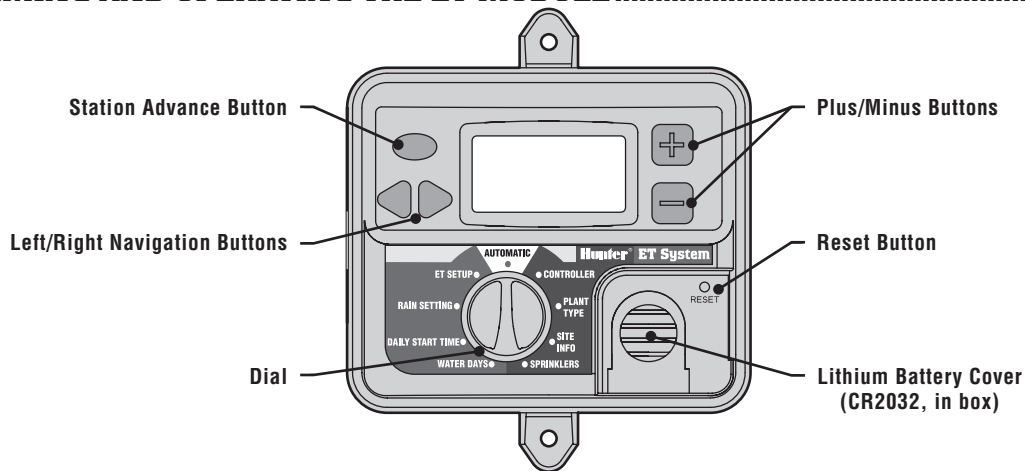

General Operating Tips

ET is reactive. You do not set the minutes (as in traditional controllers). ET looks at the weather, and calculates the minutes for you. You see what it did after the fact (Station Histories).

If you want more or less water, change either:

1. Global % Adjustment (ET Setup dial position). This will change the amount of watering for all stations, by a percentage.

2. Station settings (Plant, Site Info, and Sprinkler dial positions). This information controls how each station is calculated to water. Individual stations can have their settings changed to produce the desired results.

It can take several weeks to dial in a new system for desired performance. Make your best effort at the original setup information, but observe the results. It is common for adjustments to be made in the start up period.

Enter all settings and track your changes on the ET System Worksheet.

The ET Module has a backlit LCD display, a dial, and 5 buttons. There is also a recessed Reset button, and a removable lithium battery cover.

The display is backlit whenever the 24V power (from the SmartPort) is present.

When power is initially turned on with the dial in the Automatic position, the display will momentarily show a welcome screen, and will then show the Date and Time and the Current ET. Initially, this may be 0.00 until the sensor has accumulated enough data to generate an automatic ET (this may take up to one hour).

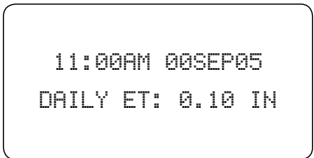

Setup Overview

Setup is simplified by following the dial clockwise all the way around, and entering data for each station until setup is complete.

First, select the controller type and station size (*international users, select Metric measurement first, at the ET Setup dial position*).

Then, each station will receive its own data for Plant, Soil, and Sprinkler types.

Other options related to automatic operation are set, and finally the

dial is returned to the Automatic position (straight up, or 12 o'clock position). The module will now be ready to run ET-based automatic irrigation.

The ET Module dial must be left in the Automatic position, or the ET program will not irrigate! If the ET System is watering, moving the dial from the Automatic position will cause it to stop.

Global ET % Setting

The ET System uses the modified Penman-Monteith equation to determine moisture loss from evapo-transpiration. The % of actual ET used is now adjustable. This allows irrigation to be adjusted based on a percentage of measured ET, and allows the system to run "wetter" or "drier" to customize performance for specific landscapes.

ET System is preset to operate with 80% of ET. However, this can be adjusted (in 1% increments) from 10% to 150%. The higher the %, the "wetter" the system will run. The adjustment is applied equally to all stations, which are further modified by their individual settings (Plant, Site Info, and Sprinkler types). This factor may compensate for non-ideal mounting conditions, where the sensor cannot be placed according to ideal specifications.

Hunter recommends observing performance carefully over the first weeks of operation and adjusting the percentage to tweak system performance.

Initial Soil Deficit

ET System assumes an initial soil deficit of .1" of water, meaning the soil is neither saturated nor dry. This relatively neutral value prevents excessive watering after initial installation.

If soil is very dry when the system is installed, it may be desirable to run all stations from the host controller first, with Manual Program starts, for a "normal" watering. Do not over water, but bring the soil to a naturally moist state before beginning ET operations.

International Users – Metric Setting

ET System is set to Inches-style measurement, but can be quickly set to Metric. Turn the dial to the ET Setup position, before entering the other setup screens.

ENABLE ET: YES
UNITS: INCHES
ET SOURCE: SENSOR
ET ADJUST: 88%

Use the right arrow key to advance to the UNITS: INCHES position.

Use the +/- keys to change the display to METRIC.

Turn the dial to save the setting. For initial setup, turn the dial to the Controller Type dial position. Millimeters will now be used in the displays in other dial positions.

Controller Type

Use the +/- keys to enter the number of stations you will be controlling with ET. Press and hold either key to accelerate the setting.

At the Controller Type dial position, select the type of Hunter controller to which the ET Module is connected. Use the +/- keys to cycle through the valid selections: SRC, Pro-C, ICC or ACC.

When the correct controller is displayed, use the Left/Right arrow keys to advance to the station size.

The ET Module will not allow a number greater than the maximum size for the selected controller.

NOTE: Enter only the number of stations you wish to control with ET—they will all run through Program A (except in the ACC controller).

It is possible to allow other stations to run in the controller's other programs (B, C, or higher in some models) with traditional programs. These other programs will always run for the set Run Time in hours: minutes.

Note that these other programs will not "stack," and their Start Times must be set to a safe time, after all ET stations will have completed. The ET System Start Time will cancel any other programs that may be running, and will prevent any new programs from beginning, until the ET watering is complete (except in the ACC controller). The best practice is to calculate the longest likely run times for the ET adjusted

stations, and add the total to the ET System Start Time. Set the Start Times for any other programs after this longest possible ET water window, or set them to complete before the ET Start Time.

Prepare the Controller

The ET System connects to any Hunter SmartPort®-equipped irrigation controller. The controller must be properly prepared to work with ET prior to use.

ICC, Pro-C, SRC (or SRC Plus) Controllers

- **Program A will be erased.** ET System will use the controller's Program A as a storage area for its ET-based run time information. Any information in the controller for Program A will be lost, after ET System communicates with it. If the Program A information was valuable, it is a good idea to write the day/start/run time information down before connecting ET System.

ET System will not begin to water immediately, and Program A will not be cleared until ET System decides to water. The system begins with an initial soil deficit of .1"/2.54mm. This means it assumes the soil is fairly moist, and that plants and soil are in good condition.

The local ET will then begin to build up, meaning the soil will become drier. When the moisture level is low enough, ET System will schedule irrigation and then Program A will be erased. This may take several days

- **Adjust other Program Start Times.** Programs B, C, and (in ICC only) D can still be used when ET System is connected, but not at the same time as the ET station program coming from the ET System. If it is still necessary to use the other programs, adjust their start times so that they will never overlap the longest program that ET System is likely to create. When ET starts running stations, it will automatically cancel all other programs (including D in the ICC) that may be running at that time, and will prevent any other programs from starting.
- **Move the Station wires (if necessary).** ET System will control the number of stations it is told to control, but does not know

where they are in the host controller. It will assume it controls from station 1, to the highest numbered station it knows about, in consecutive order. If there are stations for which ET control is not desired, their wires should be moved to the highest-numbered station positions. Be sure to change the Pump/Master Valve settings for those stations if applicable (Pro-C and ICC only).

Example: A 9-station Pro-C controller has two stations, 3 and 5, for which ET control is not desired. At the Controller dial position, ET System is told that it is a 7-station system. Since ET System will assume control of the first 7 stations, move the valve wires for stations 3 and 5 to stations 8 and 9, and move the former stations 8 and 9 to the 3 and 5 positions. ET System cannot skip stations. It will accept any number of stations, from 1 to xx, regardless of the controller type selected.

ACC Controllers

The Hunter ACC controller is compatible with ET System, but setup is somewhat different. See installation section for use of the ET/ACC adapter.

- **Program A is not erased:** ET System will not affect controller Program A directly. It will issue its run commands directly from the ET Module.
- **Overlapping (with other Programs):** ET System stations may overlap other ACC controller programs which happen to be running (within the controller's or user-program's maximum number of overlapping stations), which is not possible in ICC, Pro-C, or SRC. However, if ET System and the ACC controller try to run more than 6 stations (or the user programmed maximum) at once, ACC will cancel any irrigation over the maximum, and watering may be postponed or lost. Avoid overlapping ET with other programs unless absolutely necessary, to prevent confusion.
- **Flow:** ACC controllers may also be equipped with flow meters, and high or low flow shutdowns will not be known to the ET System (it will think it has watered correctly). Compensate for any lost irrigation by manual watering, after the flow condition has been fixed.
- **Move the Station wires** (if necessary). This applies to ACC as it

does to the other controllers: all stations for the ET control should be first, in consecutive order from station 1 to the highest number to be controlled by ET, followed by any non-ET stations that the ACC will run in other programs.

Set Time/Date

The ET Module keeps its own time, separately from the irrigation controller, and the current date/time must be set at the Controller Type dial position.

After the station size has been set correctly, use the right arrow key to advance to the hour position.

Use the +/- buttons to enter the correct hour. Press and hold either key to accelerate the setting.

Use the right arrow key to advance to the minute position, and use +/- to enter the minute.

Use the right arrow key to advance to the AM/PM setting, and use +/- to finish the time setting.

AM/PM International Time definitions (in 24-hour clock terms):

0000 – 1200 = AM (Latin **Ante Meridiem**, before noon)

1201 – 2359 = PM (**Post Meridiem**, after noon)

Midnight = 12 AM

Noon = 12 PM

Continue to set the date with the right arrow key. Set the date, month, and year separately, using the +/- at each position, and the right arrow to move positions (dd/mm/yy).

Set Daylight Savings

ET Module can automatically adjust for Daylight Savings time changes.

After the time and date are set, use the right arrow key to advance to the Daylight Savings position.

Use the +/- keys to select either USE or DO NOT USE.

If Daylight Savings is set to USE, the time will change forward one hour at 2 AM on the last Sunday in March, and will change backward one hour at 2 AM on the last Sunday in October.

When the Controller Type settings are complete, turn the dial to save the information. For initial setup, proceed to the Plant Type dial position.

Individual Zone Setup

Once the general setup settings have been made, it is necessary to enter the characteristics of each station, or zone, of irrigation in the ET Module.

The 3 dial positions Plant Type, Site Info, and Sprinkler Type need to be completed for each zone. This may be done one of two ways:

- 1) Go to each dial position and advance through all stations. Enter the Plant Types for each station, turn to Site Info and advance through all stations again, and finally turn to the Sprinkler Type position and repeat for all stations.
- 2) It is easier for some to set all characteristics for each zone, one at a time. ET System will stay on the same selected station through all 3 dial positions, so you can select a station and choose the Plant Type, turn to Site Info and enter the slope, soil, and sun data, then turn to Sprinkler Type and set the precipitation rate. Select the next station and repeat, until all stations have all data.

Multiple Plant Types Per Zone:

Occasionally a single zone of irrigation will water several different types of plants. This is not ideal, but the correct approach in this case is to set all characteristics for the most sensitive (to watering) plant species in the zone. If one of the species is highly susceptible to under- or over watering, use that plant's characteristics for all zone setup information.

The "zone" is the minimum level at which automatic irrigation control is possible. If damage to valuable landscaping or specimen plantings is feared, do not include the station in the ET setup at all, or physically add an additional zone to the system.

Plant Type

At the Plant Type dial position, select and customize the actual plants irrigated by each zone of irrigation. There is one screen for each zone (if there is more than one plant type within a zone, select the type most sensitive to watering).

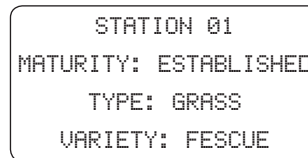

Set all information for one zone (or station), then advance to the next station with the Station button on the ET Module.

Use the right arrow key to advance through the fields, and the +/- buttons to scroll through all possible selections.

Maturity

There are only two maturity settings for all plant types, NEW or ESTABLISHED.

Established indicates normal watering requirements for turf or plants.

New indicates adjusted watering for the higher needs of growing plants which do not yet have established root zones. The New setting will automatically change to "Established" after a preset period of days, depending on the Plant Type selected.

If a plant type is entered as "New", the starting crop coefficient will "mature" over time to an established plant crop coefficient based on the plant type:

- Grass: 42 days (6 weeks)
- Shrub: 3 months
- Tree: 7 months
- Annual/Perennial/Biennial: 30 days
- Native/Desert: 6 weeks

The setting can also be changed manually at any time.

Type

Selects the general plant type, from a table of choices.

The Type setting chooses the general category of plant, based on groups defined in WUCOLS (Water Use Classification of Landscape Species). This important setting will tell the system the plant's characteristics including the depth of the root zone, and the sensitivity of the species to watering. It combines with the Variety setting to create a crop coefficient (Kc) as well as root depth and other factors.

Variety

Selects the exact, or similar, species under Types.

NOTE: The included plant types are based on recognized categories of plants, by watering needs. The plant type choices in the ET System are representative of the different levels of watering requirements of typical plants, and are based on the *Water Use Classifications of Landscape Species (WUCOLS) Guide* developed by the University of California (available on the internet from the California Department of Water Resources, at <http://www.owue.water.ca.gov/landscape/faq/faq.cfm>).

If an exact plant is not represented, there are two options:

- 1) Choose the closest type, based on the plant's watering needs. This is generally adequate.
- 2) Customize one of the existing plant types. This is described in detail below the plant type table.

For further information on regional plant data, consult an agronomist or regional county extension office.

ET System built-in menu selections (samples shown are representative of each variety):

| TYPE | Grass | Shrub | Ground Cover | Vine | Tree | Perennial | Desert |
|---------|---------------|--|----------------------------------|---------------------------------|--|-------------------------------------|-----------------------------|
| VARIETY | FESCUE | HIGH WATERING: Azalea | HIGH WATERING: Babys Tears | HIGH WATERING: Climbing Rose | HIGH WATERING: Willow, Birch | HIGH WATERING: Horsetail | LOW WATERING: Turpentine |
| | SEASONAL RYE | | | | | | |
| | BLUEGRASS | MEDIUM WATERING: Rose of Sharon | MEDIUM WATERING: White Clover | MEDIUM WATERING: Wisteria | MEDIUM WATERING: Pecan, Cypress | MEDIUM WATERING: Phlox, Geranium | |
| | BENTGRASS | | | | | | |
| | BERMUDA | | | | | | |
| | ST. AUGUSTINE | LOW WATERING: Bougainvillea | LOW WATERING: Ice Plant | LOW WATERING: Grape, Coral | LOW WATERING: Primrose | LOW WATERING: Pampas Grass | |
| | ZOYSIA | | | | | | |
| | BAHIA | | | | | | |
| | CENTIPEDE | MINIMUM WATERING: Saltbrush Jojoba | MINIMUM WATERING: Rhagodia | MINIMUM WATERING: Pipestem | MINIMUM WATERING: California pep- per tree | MINIMUM WATERING: Daffodil | MINIMUM WATERING: Cactus |
| | BUFFALO | | | | | | |
| | CARPET | | | | | | |
| | KIKUYU | | | | | | |

When all information for a station or zone has been set, use the Stations button to proceed to the next station, or turn the dial to Site Info to continue setup for the selected zone.

Customize Plant Type: Each plant type and variety results in a Crop Coefficient, which ET System uses to determine the actual amount of watering for the zone. Crop Coefficient is abbreviated “Kc” in the notation used in the ET calculation.

Through a hidden feature, ET System permits customization of the stored plant types for unusual or extreme types and conditions.

At the Plant Type dial position, enter the nearest Type and Variety for the station to be customized.

Turn the dial back to the Automatic position to save the station setting.

Hold down both the + and – buttons, and turn the dial back to the Plant Type position. Release the + and – buttons.

The Station number will be highlighted, and the display will now also show the Kc (crop coefficient) associated with the current selections.

Use the right arrow key to move to the Kc= position. The Kc value can then be changed up or down, with the + or – button. Use them to set a custom Kc for that zone.

Move the dial to another position to save the custom crop coefficient for that zone. The change only applies to the customized station, and must be repeated for any similar custom plant types.

When all stations have Plant Type data entered, turn the dial to save the information. For initial setup, proceed to the Site Info dial position.

Site Info

At the Site Info dial position, select and customize the slope, soil, and sun exposure for each zone of irrigation. There is one screen for each zone (if there is more than condition within a zone, select the type which predominates).

Use the arrow keys to advance to each value, and the +/- keys to cycle through the choices.

```
STATION 01
SLOPE: 00%
SOIL: LOAM
SUN: PART SUN
```

Slope

This value (along with SOIL) is used to determine automatic cycles and soaks for each station, based on the probable run-off of irrigation.

Use the +/- keys to set the percentage of slope, from 0 to 50% in 1% increments. If the ground is flat, leave this setting at 0%.

Determining the slope percentage: The slope is defined as the amount of elevation change, or Rise, divided by Run (the measured distance), multiplied by 100. If an irrigated area rises 2 (feet or meters) over 15 (feet or meters), the slope is approximately 13%: $(2/15) \times 100 = 13.333$.

Soil

Soil type (or texture) is used together with the SLOPE information to determine the Intake Rate of the soil, resulting in cycle and soak scheduling.

Use the +/- key to select from the following soil types:

- Sand: Predominantly Sandy soil
- Loamy Sand
- Sandy Loam
- Loam: Predominantly loamy soil
- Clay Loam
- Silt: Predominantly silt soil
- Silty Clay
- Clay: Predominantly clay soil

Automatic Cycle and Soak: A maximum run time before runoff irrigation from the sprinklers occurs will be calculated, based on the slope and soil settings. A station is only allowed to run continuously up to that time limit.

If the zone needs more water, ET System will shutoff for a soak period, determined by the Slope and Soil settings, to allow the water to soak into the earth. Other stations can run during the station's soak time, if they are able. When the soak period has elapsed, the ET System will re-activate the station at the next opportunity to continue irrigating. This process will repeat until the full application amount is complete.

Advance to the next station with the station button, or turn the dial to continue to Sprinkler Type setup of the selected station.

Sun

Sets the average amount of sunlight for each irrigated area, according to the following values:

- Full Sun – 100 percent of solar portion of ET
- Part Sun – 75 percent of solar portion of ET
- Part Shade – 50 percent of solar portion of ET
- Full Shade – 25 percent of solar portion of ET

The ET System is equipped with a solar radiation sensor and measures daily sunlight (this is why the ET Sensor platform is mounted in full sunlight). However, the irrigated areas may be in a variety of different sunlight conditions, and this setting provides an offset for the sun measured at the sensor, and the sun which probably reached the plants in a given zone. Zones are assumed to be in full sun, unless you enter a different setting here.

Set the SLOPE, SOIL, and SUN for each station. Advance to the next station with the station button.

When all stations have Soil Type data entered, turn the dial to save the information. For initial setup, proceed to the Sprinkler Type dial position.

Sprinkler Type

At the Sprinkler Type dial position, select the type of sprinkler which irrigates each station or zone. This setting determines the Precipitation Rate for each zone, which is a critical setting in determining the Run Time for each station.

Use the arrow button to navigate to the Sprinkler Type under the station number, and use the +/- keys to choose one of the sprinkler types available (or create a Custom type).

```
STATION 01
  ROTOR
PRECIP IN/HR: 0.50
RUNTIME H: MM 0:00
```

To simplify setup, several standard types of irrigation devices are included, along with typical precipitation rates. Select the type closest to the irrigation for the zone.

- Rotor – 0.5 in/hr
- Spray – 1.6 in/hr
- Drip – 0.35 in/hr (this can vary widely and should be checked for accuracy)
- Bubbler – 1.16 in/hr (this can vary widely and should be checked for accuracy)
- Custom – entered by user (based on field tests)

Precip

The Precipitation Rate is specified in inches or millimeters per hour. The Precipitation setting is based on the Sprinkler Type and cannot be changed directly, except when “CUSTOM” has been chosen. The longer a station runs, the more inches or millimeters it adds to the root zone of the plants. ET determines how many inches or millimeters were lost; Precipitation Rate determines how long the station needs to run, to replace the lost water.

Sprinkler types should not be mixed within a single zone.

RUNTIME

RUNTIME is for information only, and cannot be set at this screen. The RUNTIME field shows how long a station with the selected Sprinkler Type and Precipitation rate will run, based on the current ET.

The run time shown is based on the last 24 hours ET plus the default soil deficit of .1"/2.5mm. It is only used as a reference for the effect that changing the precipitation rate may have, and does not indicate how long the sprinkler is going to run at the next watering.

Determining Precipitation Rates: The sprinkler types included in the ET System are typical values for common types of irrigation zones. If greater accuracy is desired, a few simple tests to spot-check actual zones can be performed, and the results can be entered at the CUSTOM Sprinkler Type selection.

One informal method to determine a sample Precipitation Rate is to place catchments at intervals over the area irrigated by a single zone. There are officially calibrated catchment kits, or straight-sided metal cans of equal height can be used.

The catchments should be placed at different distances from the sprinkler heads. The more catchments, the better the test.

Run the zone for an exact period of time, divisible into 1 hour. 5 minutes is a good quick test for spray heads; 15 minutes might be better for rotor zones.

Measure the amount of water in each catchment as accurately as possible. A metal ruler or machinist's scale is good for this purpose.

Add the measurements of all the containers, and divide the total by the number of containers, to get the average precipitation for the test period. Irrigation consultants will generally establish a factor for distribution uniformity (DU) that indicates the overall efficiency of a zone. For ET System purposes, the precipitation rate entered should be the adjusted rate, and the averaging process described here will usually be adequate.

Multiply the results by the number of times the test period will divide into 1 hour (12 x 5 minutes for the sprays, 4 x 15 minutes for the rotors, in the example), to get the Precipitation Rate in inches or millimeters per hour.

This is the amount to enter for "CUSTOM" in the Sprinkler Type dial position.

Enter a Custom Precipitation Rate: Use the +/- keys to cycle through the choices until CUSTOM is displayed.

Use the arrow keys to advance to the PRECIP position. The Precipitation will be set to 1.6"

Use the +/- keys to change the Precipitation Rate to the desired number.

Continue to enter Sprinkler Type data for each station, by pressing the STA button and repeating the sprinkler selections, until finished.

When all stations have Sprinkler Type data, turn the dial to save the information. For initial setup, proceed to the Water Days dial position.

Water Days

The Water Days dial position sets the days of the week on which it is permissible to water. This does not necessarily mean watering will occur on Days OK to Water, only that it is permitted if conditions require watering.

Water Days apply equally to all stations, and only need to be set up in a single screen (not one per station).

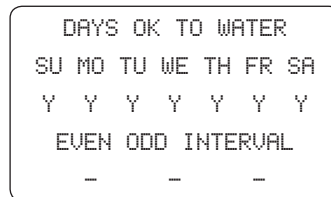

All days will initially be set to Y (Yes). The first day (Sunday) will be highlighted. To change the Y to N (No), use the +/- keys. Set any days on which you are not allowed to water, or don't wish to water, to N.

When the Y/N setting is changed, ET System will automatically jump to the next day. Use the left key to go back, if the day Y/N setting needs to be changed again.

Use the right arrow to skip past days that do not require changing. Use +/- to set each day to Yes or No; when the week is set up correctly, turn the dial to the next position.

Interval Days:

ET System can be programmed to water on intervals, instead of specific days of the week. Use the arrow keys to move to the Interval position, and press the + button. The dash will change to a Y under Interval, and the interval settings will replace the Day of Week display.

You may set from 1 to 31 day intervals. Use the arrow keys to move to the Interval field, and press +/- to set the Interval.

```

DAYS OK TO WATER
INTERVAL: 01 DAYS
REMAINING: 00 DAYS
EVEN ODD INTERVAL
  -   -   Y

```

“Remaining” is used to indicate the number of days until the next watering. If you need to set an Interval of every 3 days, but you do not want that pattern to begin until 2 days from now, enter “2” at Remaining. In two days watering will be permitted, and the every-3-day pattern will begin from that day.

To exit the Interval mode and return to another type of day schedule, use the arrow keys to move back to the Interval position at the bottom of the screen, and press the – key to change the Y to a dash [-]. The Day of Week display will return and you can make other selections.

Even/Odd Days:

ET System can be programmed to water on Even or Odd dates of the month to conform to local watering restrictions.

Use the arrow keys to move to the Even or Odd position, and press the + button. The dash will change to a Y under the selection, and all other positions will change to a dash [-]. ET System will only permit watering on the selected Even or Odd dates in this position.

```

DAYS OK TO WATER
SU MO TU WE TH FR SA
  -   -   -   -   -   -
EVEN ODD INTERVAL
  Y   -   -

```

To exit Even/Odd mode, use the arrow keys to move back to the selection and press the – button to change the Y back to a dash. The Day of Week display will return and you can make other selections.

ET System does not necessarily water on every day that has a Yes, for OK to Water. These are only the days on which it is *allowed* to water. For further information on this, refer to the section, “How ET System Decides to Water”, in the System Overview near the beginning of this manual.

When the days are set correctly, turn the dial to save the information. For initial setup, proceed to the Daily Start Time position.

Daily Start Time

The Daily Start Time dial position sets the time of day at which irrigation is allowed to begin.

```

10:00PM
WILT GARD™: ON
WILT RUNTIME: 14MIN

```

If ET System decides to water on a specific day, the irrigation will begin at the Start Time entered in this screen.

Use the +/- key to set the hour.

Use the arrow key to move to the minute position, and then use the +/- keys to set the minute.

Use the arrow keys to move to the AM/PM setting, and use the +/- keys to set AM or PM.

There is only one setting for the Daily Start Time (not one for each station), and all irrigation for that day will run sequentially beginning at that time.

WiltGard™

WiltGard is a unique feature that prevents damage to plants in extremely hot conditions, by triggering watering when damage may occur, regardless of the normal start time. WiltGard is especially well suited to cool turf grasses in desert environments, or other sensitive plants that can reach the wilting point due to extremes between daily start times. In other words, WiltGard is emergency watering that will

start whenever the plants in a zone are threatened.

The default setting is WiltGard = Off. To enable WiltGard, use the arrow keys to advance to the OFF position, and use the +/- keys to change the setting to ON.

If WiltGard is ON, watering may start without warning at unexpected times of day. Do not enable WiltGard if this creates a hazardous or inconvenient condition!

The actual Wilt Runtime cannot be set from this screen, and is only shown for information. WiltGard's run time is created automatically, based on the settings for each specific zone. WiltGard will base its "emergency" run time on 50% of the MAD (Management Allowable Depletion)

The WiltGard watering is tracked for ET purposes, and a portion of it will count against the daily ET (in other words, it will be deducted from the scheduled irrigation at the automatic start time).

The WiltGard Off/On setting applies to all zones. However, WiltGard will only start zones whose plants are in danger of damage (based on the plant and soil settings for the individual zones).

When the Start Time and WiltGard settings are correct, turn the dial to save the settings. For initial setup, turn the dial to the Rain Setting position. WiltGard is automatically turned OFF if the No Water Time feature is used.

Non Water Windows

ET System allows you to set legal watering days and a Start Time. Non Water Windows allow you to block out periods of each day during which watering is forbidden, by local watering restrictions.

Unfinished watering can resume after the end of the non water window, but the system can also be set to prevent watering past midnight (into a non water day) or at any other Day End you choose to set.

To Set the Non-Water Window:

Turn the dial to the Start Times position.

Set the Start Time normally with + and – buttons.

Use the arrow buttons to move to the No Water Time position.

```
START: 03:00AM
NO WATER TIME: OFF
WILTGARD: OFF
DAY END: 12:00AM
DAY END STOP?: NO
```

Use the + or – buttons to change OFF to the time of day that starts the No Water Time. Make sure the AM/PM selections are correct.

Use the arrow buttons to move to the No Water End, and use the + or – buttons to set a No Water End time (Default is 8:00PM). This will allow unfinished watering to resume where it left off.

This will automatically set the WiltGard feature to OFF. WiltGard cannot be used with No Water Times.

```
START: 03:00AM
NO WATER TIME: 08:00AM
NO WATER END: 08:00PM
DAY END: 12:00AM
DAY END STOP?: NO
```

When the No Water Time is set, ET System will automatically pause watering (wherever it is in the zones and cycles) at the No Water Time.

Whenever a No Water Time pauses during active irrigation, a status message will appear to indicate that there are still unfinished watering events being held during the pause.

```
08:15AM 04APR07
WATER WINDOW PAUSE
STATION 05
```

Do not touch or turn the dial during the Water Window Pause. If the

dial is turned to any other position, watering will be terminated and will not resume!

Day End

Day End is normally set to midnight (12:00AM). Watering that starts on a legal watering day is often allowed to cross over midnight, and when this is desired, set Day End Stop to N (no).

If Day End Stop is changed to Y (yes), the watering is not allowed to cross over into the next day, and all further watering will be cancelled until the next legal watering day.

You can also change the Day End time, if watering must be stopped before midnight.

| Start Time | No Water Time | No Water End | Day End |
|------------|---------------|--------------|--------------------|
| 3 AM | watering | 8AM | Water Window Pause |
| 8PM | watering | 10PM | |

This can actually create two separate water windows within a day.

For example, if you are allowed to water until 10 PM but not after:

Use the arrow buttons to move to the Day End setting, and use + or – to change the day end time to 10:00 PM.

Use the arrow buttons to move to Day End Stop, and use + or – to change to Y.

```

START: 03:00AM
NO WATER TIME: 08:00A
NO WATER END: 8:00P
DAY END: 10:00PM
DAY END STOP?: Y
    
```

You must set Day End Stop to Y, to prevent watering past the end time!

Watering will then be permanently stopped for the day at 10 PM.

Unfinished Watering

With a large system and dry weather, it is possible that the No Water Times and Day End settings that are too short to complete all the watering calculated for the zones.

When the No Water Time interrupts watering, the display shows Water Window Pause. This means there is still unfinished watering that will resume after the No Water Time ends.

```

11:15PM 04APR07
DAY END STOPPED!
STATION 06
CHECK HISTORY
    
```

Do not move the dial from the Automatic position while the unit is in Pause mode.

When the No Water End is passed, the system will resume irrigating where it stopped at the start of the No Water Window, and attempt to complete all watering.

If the Day End is reached with Day End Stop set to Y, and there is still unfinished watering, the system display will show Day End Stopped! and Check History. Check the watering histories to see which zones were missed, for special attention.

Rain Setting

The Rain Setting position determines how much natural rainfall is required to stop irrigation. A minimum amount is preset, and it is not necessary to adjust anything at this dial position for initial setup.

The ET Sensor is equipped with a “tipping bucket” style rain sensor. Rain is not used directly in the calculation of ET, but it can be used to a) shut off the irrigation, and b) adjust the next application of irrigation, by deducting a percentage of the naturally occurring precipitation (some rainfall is assumed to run off before absorption into the soil, and a loss factor is included).

```
RAIN SHUTOFF
THRESHOLD: .02 IN

IN ONE HOUR
```

Rain water fills a small internal cup in the sensor, which tips the bucket. For rain shutoff purposes, each tip is counted as one hundredth of an inch or .254mm.

The preset rain shutoff amount is displayed as .02"/.51mm, which is the minimum setting. This is sufficient for most applications, and most users can skip this dial position.

In some areas with frequent short, heavy downpours of rain, or very high concentrations of fog, the rain shutoff threshold can be adjusted higher. Condensing fog or dew can accumulate enough to tip the bucket over the course of a few hours, the threshold is never set below two tips of the sensor.

Use the +/- keys to change the rain shutoff threshold.

This setting applies to all stations. Turn the dial to save the Rain setting. For initial setup, turn the dial to the ET setup position.

The rain setting amount is not exact. One tip of the bucket actually equals .017"/.4318mm water, and ET System calculates the actual totals internally using the exact value. Two tips would actually equal .034"/.86mm of rain, and the ET System knows this.

However, the Rain Setting position displays these tips as rounded inches, or millimeters, for general reference. This is only used for the amount that will stop the sprinklers from running in the rain.

See the R24 explanation under View Sensor Data for a more complete explanation of rain measurement.

If the Rain Sensor has caused the irrigation to pause, the ET System display will show "RAIN PAUSE". If rainfall ceases during the automatic irrigation period, ET System may resume irrigating if the rainfall was insufficient to fully replenish the soil reservoir. The system may resume where it left off automatic irrigation, but with adjusted run

times for the amount of measured rainfall.

Rain Pauses always last for 15 minutes, after which ET System will check the sensor again. If Rain is still detected, it will begin another 15 minute pause. This will continue until the Rain has stopped, and ET System determines that watering is still required. If the measured rainfall has replenished the soil fully, ET System will cancel the remaining irrigation.

All sensor-based Pause modes (Rain, Freeze, and optional Wind) are tracked in the watering history and will be reported for the days on which they occurred.

ET Setup

The ET Setup dial position contains important settings that affect all stations.

Enable ET: Normally this is set to YES, and that is how the ET System is designed to operate.

```
ENABLE ET: YES
UNITS: INCHES
ET SOURCE: SENSOR
ET ADJUST: 80%
```

If Enable ET is set to NO, the ET System will not irrigate at all. If WiltGard was enabled (at the Daily Start Time dial position) it will also be disabled, and when the dial is returned to the Automatic position, the display will show OFF.

To disable ET, use the +/- key to change the display to ENABLE ET: NO.

The ET System display will then show OFF when the dial is returned to the Automatic position, and no automatic irrigation (including WiltGard) will take place. Setting ET Enable to NO is one way of shutting the system down for winter, or other extended periods.

Turning the host controller to Off will not stop ET System from running Program A! You must also disable ET in the ET System to stop all irrigation for an extended period.

Units: The ET System can display settings in either inches or millimeters. Use the arrow key to advance to the UNITS setting, and use the +/- keys to change the units between INCHES and METRIC.

ET Adjust: This setting adjusts the percentage of monitored ET that will be used in irrigation calculations. The default setting is 80%, which seems to fit most landscape applications. However, the adjustment factor can be changed from 10 to 150% in 1% increments to tweak the irrigation calculation for individual climates.

Use the arrow keys to move to the ET Adjust position, and press +/- to change the setting up or down.

The adjustment is applied equally to all stations, which are further modified by their individual settings (Plant, Site Info, and Sprinkler types). This factor may compensate for non-ideal mounting conditions, where sensor cannot be placed according to ideal specifications.

Hunter recommends observing performance carefully over the first weeks of operation and adjusting the percentage only as a last resort to tweak system performance.

ET Source: Normally this is set to SENSOR, meaning the ET Sensor station to which the ET Module is connected, and this is how ET System was designed to operate.

It is also possible to set ET Source to MANUAL, allowing the user to enter an ET value manually. This could be done to manually override the Sensor for some reason, or to provide irrigation when the Sensor is not physically connected.

To enter a Manual ET, use the arrow keys to move to the ET Source setting, and use the +/- keys to change the display to MANUAL.

An ET value for the day will appear in the display. Use the +/- keys to enter an ET in .01 in/.25mm increments.

When the dial is turned to the Automatic position, the display will show the time/date, and then MANUAL ET: followed by the manually entered value.

If ET SOURCE is set to MANUAL, it will remain the same every day unless it is manually updated again.

Normal settings for proper ET operation are ENABLE ET: YES and ET SOURCE: SENSOR. Do not change these except in unusual circumstances (such as Winter shutdown, or a disconnected Sensor).

This value will accrue each day, just like sensor-based ET. If the system is not set to every day watering, the Manual amount will be added each day between watering days. On the next watering day the total accrual will be replenished.

Automatic

For normal operations, the dial is returned to the Automatic position.

ET System will not irrigate unless the dial is in AUTOMATIC!

When the dial is in the Automatic position, the display should normally show the time, date, and current ET reading from the Sensor.

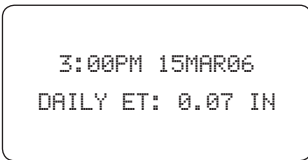

The Daily ET shows the last 24 hour total ET. The ET may fluctuate up and down, since every hour the oldest hour is dropping off, and the latest hour is added. This figure is a rolling 24 hour total and if today is cooler or cloudier than yesterday, the ET may actually decrease. The total ET since last watering is tracked by the ET Module, and will be used in the final watering calculation. The daily ET is only informational, for recent conditions.

If ET has been set to ET ENABLE: NO, the display will show OFF (to change, go the ET SETUP dial position).

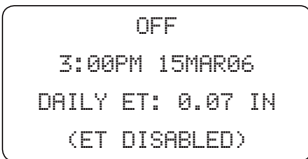

If the ET has been set to ET SOURCE: MANUAL, the current ET will be displayed along with "MANUAL". This shows that the ET has been entered manually and will not change automatically.

```
3:00PM 15MAR06  
MANUAL ET: 0.07 IN
```

When ET System is Watering: At the Automatic position, the ET Module display will show the station watering activity whenever any irrigation is occurring.

The host controller (ICC, Pro-C, and SRC) will show the display for a manual station watering. ACC controllers will show "ETS" with the station running and time remaining. This display indicates that Station 1 is active (watering), and that it is on the first Cycle of 3 scheduled Cycles.

```
WATERING  
CYCLE 01 of 03  
STATION 01: 10 MIN
```

The time showing for this station (10 Min., in the example) indicates the time remaining on this Cycle.

Based on the soil, slope, precipitation rate, and other factors, ET System has scheduled 3 different Cycles (with Soak times in between) to prevent runoff of irrigation water. The system will calculate a pause (or Soak) for the first Cycle to soak into the soil type, before applying any more irrigation.

When the station is Soaking between Cycles, and no other stations are running, ET System will indicate this in the display, along with the time remaining in the Soak period.

In the example, Station 1 is Soaking between Cycles 1 and 2 (of 3 total Cycles), and there are 32 minutes left in the Soak period before Cycle 2 begins.

```
SOAKING BEFORE  
CYCLE 02 of 03  
STATION 01: 32 MIN
```

This display will only be seen if a Soak is occurring, and ET System has no other stations to run. Normally, ET System will try to run another available station during a station's Soak period.

Watering History

To review the last 7 days worth of watering history, leave the dial in the Automatic position, and press the STA button so the Watering History screen appears.

Last Watered screen with one station event and a sensor pause.

```
LAST WATERED  
SAT 06MAR07  
STATION 01: 14 MIN  
<RAIN PAUSE>
```

Use the arrow buttons to move to the Day of week and press the + or - buttons to change the day.

```
LAST WATERED  
WED 04APR07  
STATION 06: 11 MIN  
UNFINISHED  
DAY END STOPPED!
```

Use the arrow buttons to move to the Station number, and press + or – to see the station histories on the selected day.

```
LAST WATERED
WED 04APR07
STATION 07: 05 MIN
UNFINISHED
```

This allows review of each station, on each day of the week. If only dashes --- appear, there was no watering for that station on that day.

```
LAST WATERED
WED 04-----
STATION 08: -- MIN
UNFINISHED
```

Stations that watered completely will show the minutes that the station ran. The number of cycles is no longer shown in versions 19 and later.

A station that was watering when the Day End occurred will be marked with the Day End Stopped! message.

Stations that were unfinished because of the Day End will show the total minutes that they did run, and the Unfinished message.

If the station was never able to run it will show Unfinished, but only dashes in the date and minutes fields.

Stations that were interrupted because the dial was moved will show User Pause, meaning the dial was moved out of the Automatic position.

ET System always uses Cycle and Soak. It is possible for a station to have run some of its cycles before the Day End. It will show minutes for the run time, but still show Unfinished if not all the cycles were completed.

What Happens to “Unfinished” Stations

Unfinished zones will continue to accrue a watering deficit.

The ET System knows they did not replenish completely, and on the next legal watering day it will try to replenish all lost moisture, including the deficit from the previous Unfinished day. It will begin the next legal watering with the zone that was interrupted last time.

However, it is possible in extreme conditions with severe watering restrictions that some zones will remain starved for moisture, until the restrictions are eased or the weather cools.

Unfinished Watering solutions

Verify that Start Times, No Water Time and No Water End times, and the Day End are set correctly. These define how many legal watering hours the system has to complete irrigation.

ET System automatically calculates Cycle and Soak periods for each zone, based on soil type, slope, and precipitation rate of the sprinklers.

Set a lower ET Adjust percentage at the ET Setup dial position. ET System is shipped set to 80% of ET, and a lower setting will use a smaller amount of evapo-transpiration loss to calculate new watering.

Slope setting: In extreme conditions, it is possible to “fool” the system into insuring that all zones get at least some water, by increasing the slope percentage for each zone. This will cause more, and shorter, cycles for the zones, increasing the chances that all zones get at least some water.

ET System will calculate shorter Cycle times and longer Soak periods due to the slope, and move on to the next zone. This will cause all zones to have their total run times broken up into smaller cycles, and may, with careful adjustment and observation, fit some water for each zone into severely limited watering times.

Planting low water use plants is another possibility, if these conditions are frequently encountered.

Soil amendment may also increase water infiltration and holding capacity.

Keeping irrigation hardware (sprinklers, nozzles, bubblers, and drip emitters) in good condition is vital in ET-controlled irrigation. ET controllers assume proper sprinkler performance and there is no

substitute for a well-designed and well-maintained high efficiency irrigation system.

View Sensor Data

The individual sensor readings can be seen at any time.

Turn the dial to the ET Setup position.

Press and hold the STA button for approximately 5 seconds. The sensor display will appear, in place of the ET Adjust setting.

S = Solar Radiation, hourly average in watts per m².

T = Temperature, near top of last hour.

H = Humidity (%) near top of last hour.

W = Wind: shows automatic wind factor setting, or (when optional ET Wind is installed), hourly average.

R24 = Rain (last 24 hours, max). Shows recent rainfall as number of “tips” of the rain measuring device. **The display is not in inches or millimeters, but the number of times the tipping-bucket style rain gauge has tipped.**

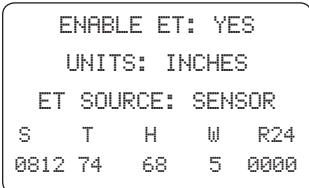

```
ENABLE ET: YES
UNITS: INCHES
ET SOURCE: SENSOR
S T H W R24
0812 74 68 5 0000
```

The module converts the tips to total inches internally, but the display is the raw data from the sensor. It shows only the number of tips in the last 24 hours, OR since the last Start Time (watering event).

1 tip of the gauge = .017” or .4318mm precipitation.

Multiply the number of tips shown under R24 by the conversion factor to obtain approximate rainfall in inches or metric.

The rain display is reset to 0000 at each start time, although the total is tracked internally.

ET System will automatically adjust for all natural rainfall. However, if it begins raining before the start time, and more rain occurs after the start time, the R24 display will only show the rain which has occurred after the start.

Reset

The recessed Reset button can be used to restore system operation in two different ways.

Restart: In rare circumstances, the ET Module’s microprocessor may become confused, and the display may “lock up”. If this, or other unusual phenomena, occurs (buttons not responding, odd symbols in the display), press the Reset button for about one second with a ballpoint pen tip, and release. This will restart the microprocessor. The display will momentarily show the welcome screen, then return to normal operations.

Restart should not erase any of the station, plant, soil, or other program data.

Full System Reset/Erase: It is also possible to completely erase the ET Module memory, to allow complete reprogramming.

This procedure will cause all station, plant, soil, and other program data to be erased! The ET System will return to factory default settings, as it came out of the box.

Hold down the + and – keys at the same time, and depress the Reset button with a ballpoint pen tip for about 1 second. Continue to hold the + and – keys for approximately one second after depressing the Reset button, and release.

The display will show “ET SYSTEM ERASING...”. The Reset process may take up to 5 seconds. When the erase is complete, the display will show the welcome screen for a few seconds, and then the screen for the current dial position. All user-programmed information will be erased.

The ET Module must now be completely reprogrammed, beginning with the first steps in this manual.

ET Reset (Deficit Clear)

It is possible to clear the watering deficit that has accrued in the ET

System. This will wipe any moisture deficits out of memory, allowing the ET watering to start over with normal soil.

ET System always shows the accumulated ET for the day in the display, at the Automatic position. It does not show all accumulated ET since the last watering, only the daily total.

It may be desirable to clear the ET after maintenance operations, or after long periods of watering inactivity.

To clear the ET and start over at 0.00 ET:

Dial at Automatic position.

Press the – (minus) button.

The Clear ET display will appear.

Press the + button to clear all ET.

To exit without clearing, turn the dial to any other position and back, without pressing the + button.

If you choose to reset ET with the + button, the display will show ET CLEARED. The ET will start over with a reading of 0.00.

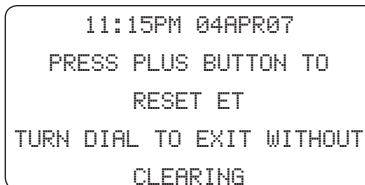

Lithium battery: The ten-year lithium battery can be accessed from the small sliding door on the front of the ET Module. This battery powers ONLY the real-time clock information, so that the time/date does not need to be updated after a short-term power failure.

All program information and the station database are non-volatile, and are not affected by this battery.

After 30 days without power, the time/date information backup will be stopped, to save the battery. This allows the battery to survive long shutdowns (such as during winter months). The time and date should only require resetting after very long periods of no power, and the battery should generally not require replacement.

TROUBLESHOOTING

| Problem | Cause | Solution |
|---|---|---|
| No display | Disconnected, or miswired SmartPort connection. | Check wiring. Verify that red SmartPort wire is connected to AC1, white wire connected to AC2. Verify that Controller has Power. |
| Frozen display or odd characters in display | Program stopped. Static electricity. | Turn off power to controller for a few seconds. Turn power back on. Press Reset button. |
| No ET reading (0.00). | Sensor has not had enough time to gather data (at system startup) | Verify ET Source (ET Setup dial position) is set to Sensor. Wait until sensors have had enough time to accumulate data. Turn dial to ET Setup, press and hold STA, to check individual sensor readings. |







| | | |
|--|---|---|
| Waters with controller dial in OFF position | ET System must also be Off. | Set ENABLE ET to NO (ET Setup position). |
| Dry or dead spots in grass | Variation in sprinklers, spacing. | Check sprinkler layout Check plant type, soil type, and slope settings Increase ET Adjust % gradually (by 5-10%) and monitor over the course of several weeks for improvement. |
| No water. | Dial not in Automatic position. ET System disconnected from controller. ET System disabled. No water days. No start time. Sensor Pause (shutdown due to conditions). Interval Days set too high for conditions. | Dial must be in Automatic. Verify SmartPort connection to controller (red, white, blue wires). Set ENABLE ET to YES (ET Setup dial position). Set water day to Y (Yes) (Water Days dial position) Set start time (Daily Start Time dial position) Check ET Module display for "RAIN", "FREEZE", or "WIND" PAUSE message... system will resume when conditions permit. Set shorter interval. |
| Too much/too little water. | Incorrect station settings. Malfunctioning sensors. ET SOURCE set to Manual. Landscape characteristics. | Verify station settings at all dial positions, including Plant Type, Site Info, and Sprinkler Type. Perform maintenance on sensors: clean out rain gauge, clean off solar radiation sensor, clear debris from "beehive" housing. Set ET SOURCE to SENSOR (ET Setup position). Use ET Adjust (ET Setup position) to control the percentage of ET used to calculate watering. |
| ET or sensor readings do not match with local weather sources. | Microclimate, sensor variations. | ET, temperatures, humidity, solar, wind and rain values can vary widely even over relatively short distances |
| Sensor Fault | Sensor miswired or missing. | Check ET Sensor wiring connections, and physical status of sensors. Voltage at sensor (green and black wires) should be 9-15VDC |

Warning: Do not paint or apply any decorations or covers to sensor platform. This could negatively affect the readings.

NOTE: This product is intended for turf and landscaping applications only, not intended for agricultural or scientific use.

ET System Diagnostics

| | |
|------------------------------------|---|
| Station Test | Dial in Auto position Push and hold left 3 buttons (STA & left and right arrow buttons) Press and release Reset button Release left 3 buttons Station 1 should run for 1-2 minutes. |
| View Sensor Data | Dial in ET Setup position Press and hold STA button Release STA button |
| View Crop Coefficients (Kc) | Dial in Auto position Push and hold both + and – buttons. Turn dial to Plant Type position Release + and - buttons |
| ET Data Erase (Hard Reset) | Dial in Auto position Push and hold + and – buttons Push Reset button for 1 second Release Reset Release + and – buttons (All Data Erased) |
| Firmware Version | Dial in Auto position Press and hold STA Press and release Reset button Release STA |
| Clear ET | Dial in Auto position Press and hold the – button for 2 seconds Release – button Push + button to clear current ET (restores deficit to .1"/2.54mm) |

| How Settings Affect Irrigation | | |
|-----------------------------------|---|---|
| Sand | Soil¹ | Clay |
| Longer cycles, faster evaporation |  | More & shorter cycles, less evaporation |
| 0%, Flat | Slope² | 45%, Steep |
| Fewer cycles |  | More cycles |
| Low | Sprinkler Precipitation³ | High |
| Longer run times |  | Shorter run times |
| Low | Plant Type (Kc) | High |
| Less watering |  | More watering |
| Lower | ET% | Higher |
| Less watering |  | More watering |
| Full Shade | Sun | Full Sun |
| Lower ET, less water |  | Higher ET, more water |

¹Sand has higher infiltration rate, but lower water holding capacity

²Cycles do not affect total amount of water, only how much is applied at once

³Lower precipitation rates require more run time to apply the same amount of water

Version History

The ET Module is run by special software called “firmware”. There have been several features added or improved over the life of the product.

Version 17, 18: added 7 day watering histories, ET Global Adjustment percentage.

Version 19, 20: streamline watering history and added Non Water Windows and related features.

Version 21: Product package includes 100’/33m approved wiring for ET Sensor.

SPECIFICATIONS

Power Input: 24 VAC, 50/60Hz (from host controller)

Current draw: 20 ma, max

Non-volatile memory

Replaceable 10-year lithium battery CR2032 (for time/date backup only)

Wiring: ET Module power, SmartPort

ET Sensor wiring, 2 x 20 AWG direct burial, color-coded. If other wire is to be used, recommend 18 AWG/1mm x 2 direct burial.

Max distance, ET Module from controller: 6 ft./2 m

Max distance, ET Sensor from module: 100 ft./30 m max.

ET SYSTEM COMPATIBILITY LIST

SRC/SRC Plus Controllers

Pro-C Controllers

ICC Controllers

ACC Controllers (with included ACC adapter)*

ACC-99D Controller (with included ACC adapter) up to 48 stations, maximum*

*ET System is technically compatible with ACC controllers, but not necessarily recommended.

DIMENSIONS

ET Module – 6" H x 4" W x 1.75" D (153 mm H x 102 mm W x 45 mm D)

ET Sensor – 10½" H x 7¼" W x 12½" D (26.7 mm H x 18.4 mm W x 30.8 mm D)

ET Sensor with pole brackets – 10½" H x 7¼" W x 13" D (26.7 mm H x 18.4 mm W x 33.0 mm D)

ET Sensor with ET Wind – 11½" H x 7¼" W x 19⅞" D (29.2 mm H x 18.4 mm W x 50.5 mm D)

ET Sensor and ET Wind with pole brackets – 11½" H x 7¼" W x 20¾" D (29.2 mm H x 18.4 mm W x 52.7 mm D) FCC Notice

FCC NOTICE.....

This equipment has been tested and found to comply with the limits for a Class B digital device, pursuant to part 15 of the FCC Rules. These limits are designed to provide reasonable protection against harmful interference in a residential installation. This equipment generates, uses and can radiate radio frequency energy and, if not installed and used in accordance with the instructions, may cause harmful interference to radio communications. However, there is no guarantee that interference will not occur in a particular installation. If this equipment does cause harmful interference to radio or television reception, which can be determined by turning the equipment off and on, the user is encouraged to try to correct the interference by one or more of the following measures:

- Reorient or relocate the receiving antenna.
- Increase the separation between the equipment and receiver.
- Connect the equipment into an outlet on a circuit different from that to which the receiver is connected.

Consult the dealer or an experienced radio/TV technician for help.