

# What's New

## 2020 PRODUCT REVEAL

# Hunter®



# A COMMITMENT TO INNOVATION

We are dedicated to providing bold irrigation management solutions that push the boundaries of innovation. See the newest additions to our product lineup on the following pages and a recap of other recently released products below.

## I-80 ROTOR

Ideal for large turf applications, the I-80 rotor offers unparalleled levels of performance, power, versatility, and safety. It is the most technologically advanced commercial rotor solution on the market.



## HCC

The HCC controller brings the powerful Wi-Fi-based irrigation management capabilities of the industry-leading Hydrowise® platform to midsize commercial and public-sector projects.



## BTT

Bluetooth® Tap Timer provides convenient Bluetooth enabled app control for automatic irrigation of gardens, terraces, plants, and flowers — right from a hose tap!



## MP815

Ideal for spray retrofits and design flexibility, the MP815 is the newest member of the MP Rotator® nozzle family. It extends a 20 mm/hr matched precipitation rate to a radius of 4.5 m while providing wind resistance and high distribution uniformity.



## Contents

| I-50

| ST-1700V

| HDL-COP

| BTT 2-ZONE

| NODE-BT

| CENTRALUS™

| X2™

| EZ DECODER SYSTEM

| WIRELESS SENSOR GUARDS

| A2C-LTE

| A2C-LEDKT

| ACC2 NETWORKING MODULES

| ACC-P2P-LTE/ACC-COM-LTE



### I-50 ROTOR

► *Estimated launch date: Quarter 4, 2019*

**The I-50 rotor delivers the highest drive output torque in its class to thrive in difficult water-quality conditions on large-turf projects.** The internal drive mechanism and arc adjustment style are derived from our time-proven and reliable golf rotors, so you can count on top performance. The I-50 has a durable stainless steel riser and colour-coded nozzles to provide years of top performance.

- Extra-strong, non-strippable drive mechanism is reliable and durable in harsh water conditions
- Tool-free, part- and full-circle arc adjustment mechanism speeds up installation and reduces inventory (50° to 360°)
- Available opposing nozzle model for even watering in full-circle applications (I-50-ON model)

I-50 MODELS	
Model	Description
I-50-06-SS	6" pop-up, adjustable arc (50° to 360°), with stainless steel riser
I-50-06-SS-ON	6" pop-up, full-circle, with opposing nozzles, with stainless steel riser



### ST-1700V ST ROTOR

► *Estimated launch date: Quarter 3, 2019*

**The ST-1700V is the perfect choice for cooling, cleaning, and preparing synthetic turf in the sports field market.** Engineered with the powerful and proven ST-1600 gear drive at its heart, this rotor integrates the control valve, solenoid, and manual ON-Off-Auto selector within a heavy-duty, impact-resistant case. Thanks to Total-Top-Service design, every component can be accessed from the surface without cutting into the synthetic turf.

- Total-Top-Service design provides convenient no-dig servicing
- Valve-in-Head configuration simplifies installation
- Heavy-duty internal gear drive provides years of reliable performance

ST-1700V MODELS	
Model	Description
ST-1700V	Rotor, valve-in-head, adjustable arc (40°-360°), 2" (50 mm) BSP inlet



## HDL-COP DRIPLINE

► *Estimated launch date: Quarter 2, 2020*

**Minimise the risk of root intrusion by adding copper to industry-leading Hunter Dripline.** The new HDL-COP is the perfect complement to the popular Hunter family of at-grade and subsurface products: HDL-PC, HDL-CV, HDL-R, Eco-Wrap®, and Eco-Mat®. HDL-COP comes with the same great features of HDL-CV, but has the added benefit of copper in the emitter to assist in preventing root intrusion.

- Copper oxide in the emitter provides root intrusion resistance and will not leach into the soil
- Slow-draining check valve prevents low-point drainage and anti-siphon feature prevents the suction of debris into the emitter
- Stretch-wrapped coils make it quick and easy to uncoil and store

HDL-COP MODELS	
Model	Description
HDL-09-12-250-COP	Hunter Dripline CV with copper, 3.4 l/hr, 30 cm, 75 m coil
HDL-09-12-1K-COP	Hunter Dripline CV with copper, 3.4 l/hr, 30 cm, 300 m coil
HDL-06-12-250-COP	Hunter Dripline CV with copper, 2.1 l/hr, 30 cm, 75 m coil
HDL-06-12-1K-COP	Hunter Dripline CV with copper, 2.1 l/hr, 30 cm, 300 m coil



## BTT 2-ZONE TAP TIMER

► *Estimated launch date: Quarter 4, 2019*

**Take advantage of smartphone-controlled, above-ground irrigation for easier access to the hose tap.** Keep nurseries, gardens, greenhouses, terraces, potted plants, flower beds, and small lawn areas automatically watered with BTT, a Bluetooth enabled, battery-operated tap timer controlled via an iOS® or Android™ smartphone app. BTT connects to a standard hose tap in minutes and batteries are included. Manage an unlimited number of controllers within a 10 m range and avoid stepping on delicate plant material to access the hose tap.

- Redesigned multilanguage smartphone app
- Increased start times and run times with visual watering history
- Battery-change reminder for site maintenance

The Bluetooth® word mark and logos are registered trademarks owned by Bluetooth SIG Inc. and any use of such marks by Hunter Industries is under license. iOS is a trademark or registered trademark of Cisco in the U.S. and other countries and is used under license. Android is a trademark of Google LLC.

BTT MODELS	
Model	Description
BTT-201	2-zone Bluetooth Tap Timer, 1" BSP and ¾" hose thread, quick couple adapter



## NODE-BT CONTROLLER

► *Estimated launch date: Quarter 4, 2019*

**Avoid the valve box with the Bluetooth battery-operated NODE-BT controller.** NODE-BT is enabled with powerful wireless technology that can be easily managed from a smartphone up to 15 m. Install the waterproof NODE-BT in highway landscapes, parks, green roofs, temporary irrigation sites, or other outdoor applications where AC power is unavailable. Users can also enable or suspend irrigation, view irrigation logs, and check battery status on the controller with the touch of a button, speeding up maintenance.

- Prevent overwatering with optional soil moisture sensor
- Redesigned battery compartment with added reliability
- Battery-change reminder for site maintenance

NODE-BT MODELS	
Model	Description
NODE-BT-100	Single-station Bluetooth battery controller and DC-latching solenoid
NODE-BT-100-LS	Single-station Bluetooth battery controller
NODE-BT-200	2-station Bluetooth battery controller
NODE-BT-400	4-station Bluetooth battery controller
NODE-BT-100-VALVE-B	Single-station Bluetooth battery controller with PGV-101G-B valve and DC-latching solenoid (BSP threads)
SC-PROBE	Soil moisture sensor probe

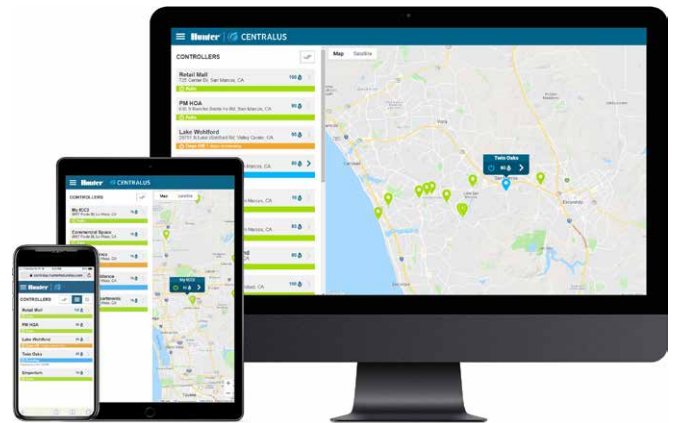

## CENTRALUS SOFTWARE

► *Launched: February 2019*

**Gain cloud-based control and monitoring for ICC2 and ACC2 controllers with the mobile-friendly Centralus irrigation management platform.** The Centralus irrigation management platform provides highly secure, comprehensive cloud-based control and monitoring features. Users can view a controller's status, change settings, view forecasts, save water, and receive instant notification of important system alarms — all without costly and time-consuming travel and site visits.

- Wide-area management platform with maps, alarms, and settings
- Connectivity via Wi-Fi, LAN (Ethernet), and cell
- Scheduling, remote control, status, and activity at a glance

COMMUNICATION MODELS	
Model	Description
WIFIKIT	ICC2 Wi-Fi connection module
LANKIT	ICC2 LAN connection module
CELL-KIT-E*	ICC2 cellular connection module, international
A2C-WIFI	ACC2 Wi-Fi module for Centralus
A2C-LAN*	ACC2 Ethernet (LAN) module for Centralus
A2C-CELL-E*	ACC2 cellular connection module, international

\*Items available in 2020



WAND Wi-Fi Module

**X2 CONTROLLER**

► *Estimated launch date: Quarter 4, 2019*

The economical X2 controller continues the legacy set by the popular X-Core® controller. X2 brings irrigation management into the next generation by providing the option to add advanced water-saving features using Hunter’s industry-leading wireless Hydrawise technology. X2 ensures healthy, green landscapes to make site management more convenient and profitable in routine installations.

- Set schedules and weather adjustments from anywhere with the simple, add-on WAND Wi-Fi module that connects to the Hydrawise platform
- Backlit display provides optimal visibility in any light
- ROAM and ROAM XL remote compatible for quicker system diagnostics

X2 MODELS	
Model	Description
X2-401-E	4-station controller, 230V internal transformer and plug with plastic cabinet
X2-601-E	6-station controller, 230V internal transformer and plug with plastic cabinet
X2-801-E	8-station controller, 230V internal transformer and plug with plastic cabinet
X2-1401-E	14-station controller, 230V internal transformer and plug with plastic cabinet
X2-401-A	4-station controller, 230V internal transformer and plug with plastic cabinet
X2-601-A	6-station controller, 230V internal transformer and plug with plastic cabinet
X2-801-A	8-station controller, 230V internal transformer and plug with plastic cabinet
X2-1401-A	14-station controller, 230V internal transformer and plug with plastic cabinet
WAND	Wi-Fi module for Hydrawise management software



## EZ DECODER SYSTEM

► Launched: January 2019

Bring two-wire technology to more projects than ever before with the revolutionary low-cost, hassle-free EZ Decoder System for HCC and ICC2 controllers.

- Two-wire simplicity and flexibility up to 54 stations (plus P/MV)
- No special wires, no special connectors, easy installation
- Programmable decoders with diagnostic LED

EZDS MODELS	
Model	Description
EZ-DM	Decoder output module for HCC and ICC2 controllers
EZ-1	Single-station decoder with status LED
EZ-DT*	Wireless diagnostic tool for EZ decoders

\*Available July 2020



## WIRELESS SENSOR GUARDS

► Estimated launch date: Quarter 3, 2019

These tools provide vandal protection for wireless Solar Sync® sensor and wireless Rain-Clik® rain sensors.

Protect wireless sensors from damage while ensuring sensors are doing their jobs adjusting irrigation schedules or shutting down irrigation when weather conditions dictate. Wireless sensor guards install to exposed flat surfaces or poles. Wireless receiver guards install to a stainless steel pedestal.

- Wireless sensors sold separately:
  - P/N WSS-SEN (Wireless Solar Sync Kit)
  - P/N WR-CLIK (Wireless Rain-Clik Kit)
  - P/N WRF-CLIK (Wireless Rain/Freeze Kit)

WIRELESS SENSOR GUARDS MODELS	
Model	Description
WS-GUARD	Vandal-resistant wireless sensor guard for flat surfaces or pole mounting
WR-GUARD	Vandal-resistant wireless receiver guard for flat surfaces or pedestal mounting

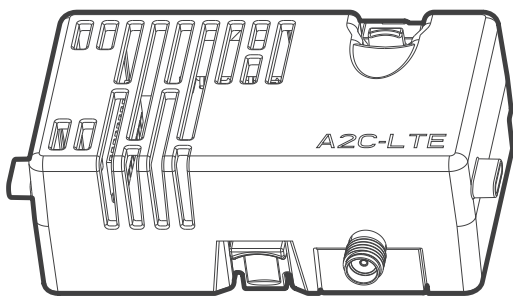

**A2C-LTE**

► *Estimated launch date: Quarter 2, 2020*

Add Centralus web-based management via cellular service to industry-leading ACC2 commercial controllers with this simple and low-cost internal module.

- Simple plug-in installation to controller panel
- Antenna included (provision for external antenna mounting available)
- Modern, cost-effective cellular data service

A2C-LTE MODELS	
Model	Description
A2C-LTE	ACC2 cellular connection module, North America
A2C-CELL-E	ACC2 cellular connection module, international

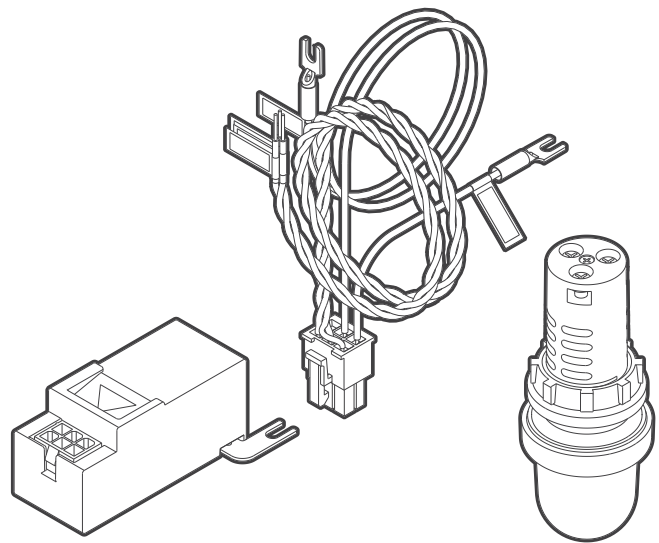

**A2C-LEDKT**

► *Estimated launch date: Quarter 4, 2019*

This external status light for ACC2 controllers allows maintenance personnel to know controller status, even with the door closed and locked.

- Easy, low-voltage installation through bottom conduit holes in controller cabinet
- Triple mode light shows Normal/Alarm/Power Outage at a glance
- Operates via controller's Conditional Response "SOS" feature

A2C-LEDKT MODELS	
Model	Description
A2C-LEDKT	ACC2 alarm output light kit



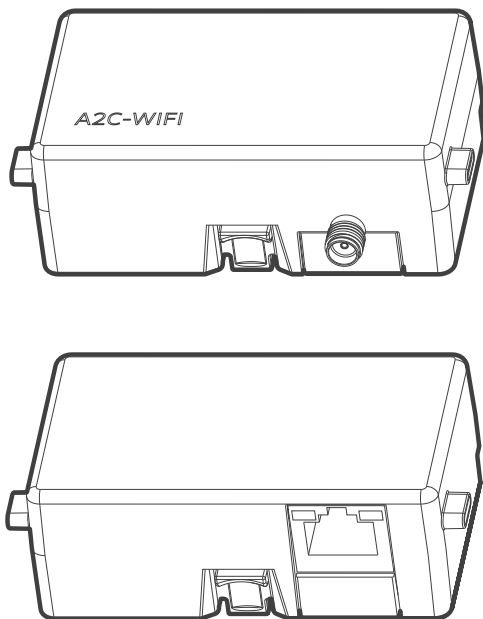

### ACC2 NETWORKING MODULES

► *Estimated launch date: Quarter 4, 2019*

Add Centralus web-based management via Wi-Fi or LAN (Ethernet) to industry-leading ACC2 commercial controllers with these flexible, low-cost internal modules.

- Simple plug-in installation to controller panel
- A2C-WIFI now allows wireless 2.4 GHz connectivity for Centralus central control (antenna included)
- A2C-LAN allows Ethernet hardwired connectivity for Centralus central control (RJ-45 receptacle)
- Uses network internet access for Centralus management and control

ACC2 NETWORKING MODELS	
Model	Description
A2C-WIFI	ACC2 Wi-Fi module with antenna
A2C-LAN	ACC2 Ethernet (LAN) module



### ACC-P2P-LTE/ACC-COM-LTE

► *Estimated launch date: Quarter 4, 2019*

Enable new cellular communications for original ACC controllers with up-to-date LTE or international data connections.

- Easily installs in the controller facepack frame (antennas included, provision for external antenna mounting available)
- Allows LTE communications (North America) or other services for international needs
- Built-in status and setup display

ACC-P2P-LTE/ACC-COM-LTE MODELS	
Model	Description
ACC-P2P-LTE	ACC LTE cell module, single controller, North America
ACC-COM-LTE	ACC LTE cell module, multi-controller, North America
ACC-COM-LTE-E	ACC LTE cell module, multi-controller, international



Helping our customers succeed is what drives us. While our passion for innovation and engineering is built into everything we do, it is our commitment to exceptional support that we hope will keep you in the Hunter family of customers for years to come.

A handwritten signature in white ink, appearing to read 'G. R. Hunter', is written over a dark blue background.

Gregory R. Hunter, CEO of Hunter Industries

A handwritten signature in white ink, appearing to read 'Gene Smith', is written over a dark blue background.

Gene Smith, President, Landscape Irrigation and Outdoor Lighting

**Website** [hunterindustries.com](http://hunterindustries.com) | **Customer Support** +1 760-752-6037 | **Technical Service** +1 760-591-7383

This brochure was printed on Forest Stewardship Council® (FSC®) certified paper with soy inks. The FSC is an international organisation established to promote the responsible management of the world's forests.



Printed using  
100% Wind  
Energy, (RECs)



© 2019 Hunter Industries Inc. Please recycle.

RC-001-BR EM 09/19

*Hunter, the Hunter logo, and all other trademarks are property of Hunter Industries, registered in the U.S. and other countries.*