

# What's New

## 2020 PRODUCT REVEAL

# Hunter®

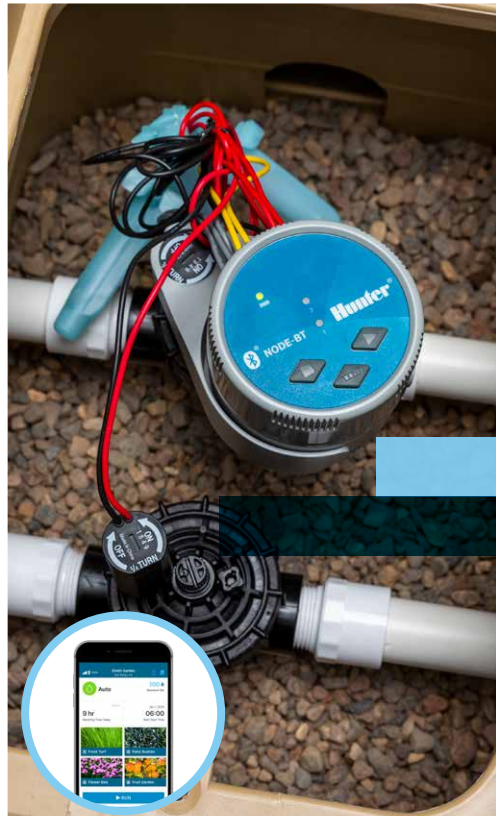

# HUNTER FAMILY

## *of Companies*

**Hunter**<sup>®</sup>

Founded in 1981, Hunter Industries is a family-owned, global manufacturer of best-in-class solutions for residential, commercial, municipal, agricultural, and golf course irrigation systems, as well as the outdoor lighting industry. CEO Greg Hunter and his executive staff provide leadership for our entire company. Our core mission will always remain the same: to deliver valued products and services backed by unwavering customer support, grow the company conscientiously, and remain true to the culture that makes our employees proud to work at Hunter. [Learn more at hunterindustries.com](http://hunterindustries.com).

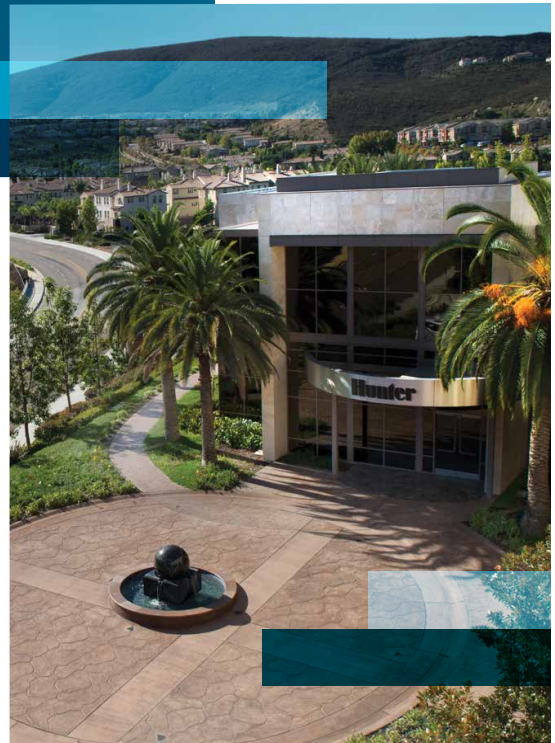

**Hunter**<sup>®</sup>  
GOLF IRRIGATION



Hunter has been on the leading edge of golf course irrigation for more than three decades. We take pride in providing golf experts and professionals with the products, tools, and support they need to conceptualize, create, and manage world-class golf courses. [Learn more at hunterindustries.com/golf](http://hunterindustries.com/golf).



**Senninger Irrigation is a principal designer and manufacturer of premier irrigation solutions** for agricultural, horticultural, industrial, and wastewater applications. With over 50 years of experience in more than 50 countries worldwide, Senninger is one of the most trusted names in the agricultural irrigation industry. [Learn more at senninger.com.](http://senninger.com)

## FXLuminaire

**FX Luminaire is an industry-leading manufacturer of landscape and architectural lighting solutions.** We focus on the advancement of LED technology and digital lighting control with smart home integration and zoning, dimming, and color generation capabilities. [Learn more at fxl.com.](http://fxl.com)

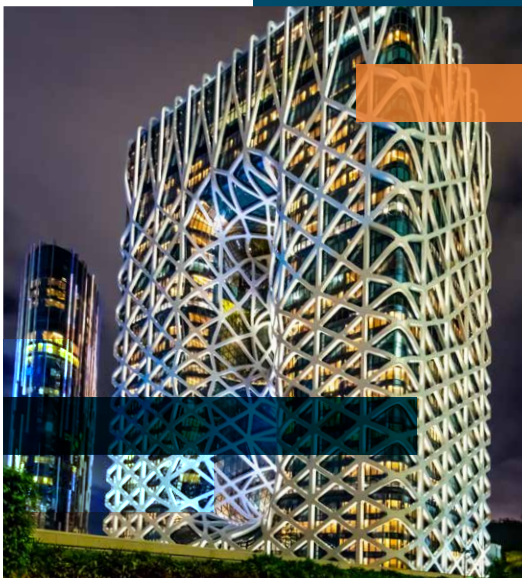
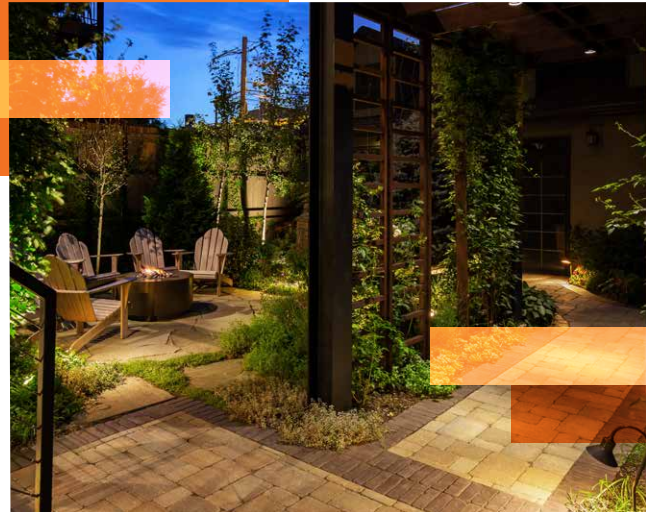

**Lumascape transforms architecture into performance art with precision-engineered lighting solutions.** Our global experts combine sophisticated design, advanced technologies, quality materials, and rigorous testing to manufacture comprehensive lighting systems that exceed expectations in a range of commercial and public-sector applications. [Learn more at lumascape.com.](http://lumascape.com)

# A COMMITMENT TO INNOVATION

We are dedicated to providing bold irrigation management solutions that push the boundaries of innovation. See the newest additions to our product lineup on the following pages and a recap of other recently released products below.

## I-80 ROTOR

Ideal for large turf applications, the I-80 rotor offers unparalleled levels of performance, power, versatility, and safety. It is the most technologically advanced commercial rotor solution on the market.



## HCC

The HCC controller brings the powerful Wi-Fi-based irrigation management capabilities of the industry-leading Hydrowise® platform to midsize commercial and public-sector projects.



## HDL

High-efficiency HDL is available in three pressure-compensating varieties to serve a range of drip system needs. Choose HDL-PC for standard installations, HDL-CV for sloping applications that require a check valve, and HDL-R when using reclaimed water.



## MP815

Ideal for spray retrofits and design flexibility, the MP815 is the newest member of the MP Rotator® nozzle family. It extends a 0.8 in/hr matched precipitation rate to a radius of 15' while providing wind resistance and high distribution uniformity.



## Contents

| I-50

| HDL-COP

| BTT 2-ZONE

| NODE-BT

| X2™

| CENTRALUS™

| EZ DECODER SYSTEM

| WIRELESS SENSOR GUARDS

| A2C-LTE

| A2C-LEDKT

| ACC2 NETWORKING MODULES

| ACC-P2P-LTE/ACC-COM-LTE

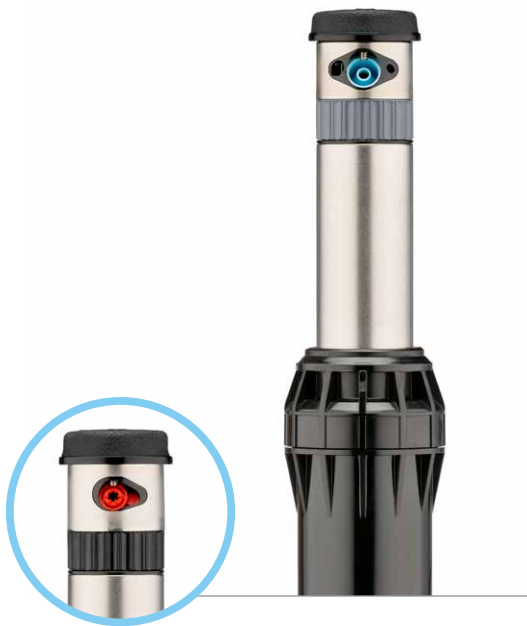

## I-50 ROTOR

► *Estimated launch date: Quarter 4, 2019*

The I-50 rotor delivers the highest drive output torque in its class to thrive in difficult water-quality conditions on large-turf projects. The internal drive mechanism and arc adjustment style are derived from our time-proven and reliable golf rotors, so you can count on top performance. The I-50 has a durable stainless steel riser and color-coded nozzles to provide years of top performance.

- Extra-strong, non-strippable drive mechanism is reliable and durable in harsh water conditions
- Tool-free, part- and full-circle arc adjustment mechanism speeds up installation and reduces inventory (50° to 360°)
- Available opposing nozzle model for even watering in full-circle applications (I-50-ON model)

I-50 MODELS	
Model	Description
I-50-06-SS	6" pop-up, adjustable arc (50° to 360°), with stainless steel riser
I-50-06-SS-ON	6" pop-up, full-circle, with opposing nozzles, with stainless steel riser



## HDL-COP DRIPLINE

► *Estimated launch date: Quarter 2, 2020*

Minimize the risk of root intrusion by adding copper to industry-leading Hunter Dripline. The new HDL-COP is the perfect complement to the popular Hunter family of at-grade and subsurface products: HDL-PC, HDL-CV, HDL-R, Eco-Wrap®, and Eco-Mat®. HDL-COP comes with the same great features of HDL-CV, but has the added benefit of copper in the emitter to assist in preventing root intrusion.

- Copper oxide in the emitter provides root intrusion resistance and will not leach into the soil
- Slow-draining check valve prevents low-point drainage and anti-siphon feature prevents the suction of debris into the emitter
- Stretch-wrapped coils make it quick and easy to uncoil and store

HDL-COP MODELS	
Model	Description
HDL-09-12-250-COP	Hunter Dripline CV with copper, 0.9 gph 12", 250' coil
HDL-09-12-1K-COP	Hunter Dripline CV with copper, 0.9 gph 12", 1000' coil
HDL-06-12-250-COP	Hunter Dripline CV with copper, 0.6 gph 12", 250' coil
HDL-06-12-1K-COP	Hunter Dripline CV with copper, 0.6 gph 12", 1000' coil



### BTT 2-ZONE MODEL

► *Estimated launch date: Quarter 4, 2019*

**Take advantage of smartphone-controlled, above-ground irrigation for easier access to the hose tap.** Keep gardens, greenhouses, terraces, potted plants, flower beds, small lawn areas, and nurseries automatically and adequately watered with BTT, a Bluetooth® enabled, battery-operated tap timer controlled via an iOS® or Android™ smartphone app. BTT installs to a standard hose tap in minutes and batteries are included. Manage an unlimited number of controllers within a 32' range and avoid stepping on delicate plant material to access the hose tap.

- Redesigned multilanguage smartphone app
- Increased start times and run times with visual watering history
- Battery-change reminder for site maintenance

The Bluetooth® word mark and logos are registered trademarks owned by Bluetooth SIG Inc. and any use of such marks by Hunter Industries is under license. iOS is a trademark or registered trademark of Cisco in the U.S. and other countries and is used under license. Android is a trademark of Google LLC.

#### BTT MODELS

Model	Description
BTT-200	2-zone Bluetooth Tap Timer, 3/4" hose thread



### NODE-BT CONTROLLER

► *Estimated launch date: Quarter 4, 2019*

**Avoid the valve box with the Bluetooth battery-operated NODE-BT controller.** NODE-BT is enabled with powerful wireless technology that can be easily managed from a smartphone up to 50'. Install the waterproof NODE-BT in highway landscapes, nurseries, parks, green roofs, temporary irrigation sites, or other outdoor applications where AC power is unavailable. Users can also enable or suspend irrigation, view irrigation logs, and check battery status on the controller with the touch of a button, speeding up maintenance.

- Prevent overwatering with optional soil moisture sensor
- Redesigned battery compartment with added reliability
- Battery-change reminder for site maintenance

#### NODE-BT MODELS

Model	Description
NODE-BT-100	Single-station Bluetooth battery controller and DC-latching solenoid
NODE-BT-100-LS	Single-station Bluetooth battery controller
NODE-BT-200	2-station Bluetooth battery controller
NODE-BT-400	4-station Bluetooth battery controller
NODE-BT-100-VALVE	Single-station Bluetooth battery controller with PGV-101G valve and DC-latching solenoid (NPT threads)
SC-PROBE	Soil moisture sensor probe



WAND Wi-Fi Module

## X2 CONTROLLER

► *Estimated launch date: Quarter 1, 2020*

The economical X2 controller continues the legacy set by the popular X-Core® controller. X2 brings irrigation management into the next generation by providing the option to add advanced water-saving features using Hunter's industry-leading wireless Hydrowise technology. X2 ensures healthy, green landscapes to make site management more convenient and profitable in routine installations.

- Set schedules and weather adjustments from anywhere with the simple, add-on WAND Wi-Fi module that connects to the Hydrowise platform
- Backlit display provides optimal visibility in any light
- ROAM and ROAM XL remote compatible for quicker system diagnostics

### X2 MODELS

Model	Description
X2-400	4-station controller, 120V internal transformer and plug with plastic cabinet
X2-600	6-station controller, 120V internal transformer and plug with plastic cabinet
X2-800	8-station controller, 120V internal transformer and plug with plastic cabinet
X2-1400	14-station controller, 120V internal transformer and plug with plastic cabinet
WAND	Wi-Fi module for Hydrowise management software

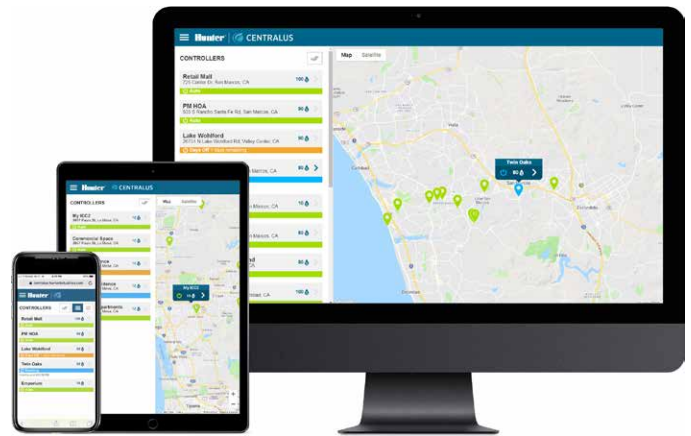

## CENTRALUS SOFTWARE

► *Launched: February 2019*

Gain cloud-based control and monitoring for ICC2 and ACC2 controllers with the mobile-friendly Centralus irrigation management platform. Centralus provides highly secure, comprehensive cloud-based control and monitoring features. Users can view a controller's status, change settings, view forecasts, save water, and receive instant notification of important system alarms — all without costly and time-consuming travel and site visits.

- Wide-area management platform with maps, alarms, and settings
- Connectivity via Wi-Fi, LAN (Ethernet), and cell
- Scheduling, remote control, status, and activity at a glance

### COMMUNICATION MODELS

Model	Description
WIFIKIT	ICC2 Wi-Fi connection module
LANKIT	ICC2 LAN connection module
CELL-KIT*	ICC2 cellular connection module, North America
A2C-WIFI	ACC2 Wi-Fi module for Centralus
A2C-LAN*	ACC2 Ethernet (LAN) module for Centralus
A2C-LTE*	ACC2 cellular connection module, North America

\*Items available in 2020



WS-GUARD



WR-GUARD

## EZ DECODER SYSTEM

► Launched: January 2019

Bring two-wire technology to more projects than ever before with the revolutionary low-cost, hassle-free EZ Decoder System for HCC and ICC2 controllers.

- Two-wire simplicity and flexibility up to 54 stations (plus P/MV)
- No special wires, no special connectors, easy installation
- Programmable decoders with diagnostic LED

## WIRELESS SENSOR GUARDS

► Estimated launch date: Quarter 3, 2019

These tools provide vandal protection for wireless Solar Sync® sensor and wireless Rain-Clik® rain sensors.

Protect wireless sensors from damage while ensuring sensors are doing their jobs adjusting irrigation schedules or shutting down irrigation when weather conditions dictate. Wireless sensor guards install to exposed flat surfaces or poles. Wireless receiver guards install to a stainless steel pedestal.

- Wireless sensors sold separately:
  - P/N WSS-SEN (Wireless Solar Sync Kit)
  - P/N WR-CLIK (Wireless Rain-Clik Kit)
  - P/N WRF-CLIK (Wireless Rain/Freeze Kit)

EZDS MODELS	
Model	Description
EZ-DM	Decoder output module for HCC and ICC2 controllers
EZ-1	Single-station decoder with status LED
EZ-DT*	Wireless diagnostic tool for EZ decoders

\*Available July 2020

WIRELESS SENSOR GUARDS MODELS	
Model	Description
WS-GUARD	Vandal-resistant wireless sensor guard for flat surfaces or pole mounting
WR-GUARD	Vandal-resistant wireless receiver guard for flat surfaces or pedestal mounting



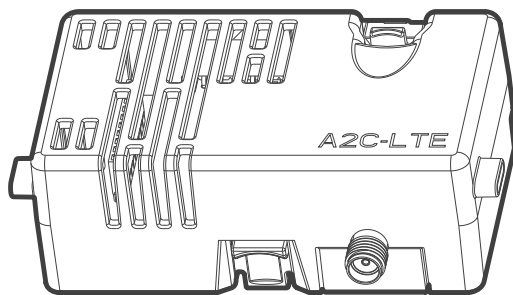

## A2C-LTE

► *Estimated launch date: Quarter 2, 2020*

Add Centralus web-based management via cellular service to industry-leading ACC2 commercial controllers with this simple and low-cost internal module.

- Simple plug-in installation to controller panel
- Antenna included (provision for external antenna mounting available)
- Modern, cost-effective cellular data service

### A2C-LTE MODELS

Model	Description
A2C-LTE	ACC2 cellular connection module, North America
A2C-CELL-E	ACC2 cellular connection module, international

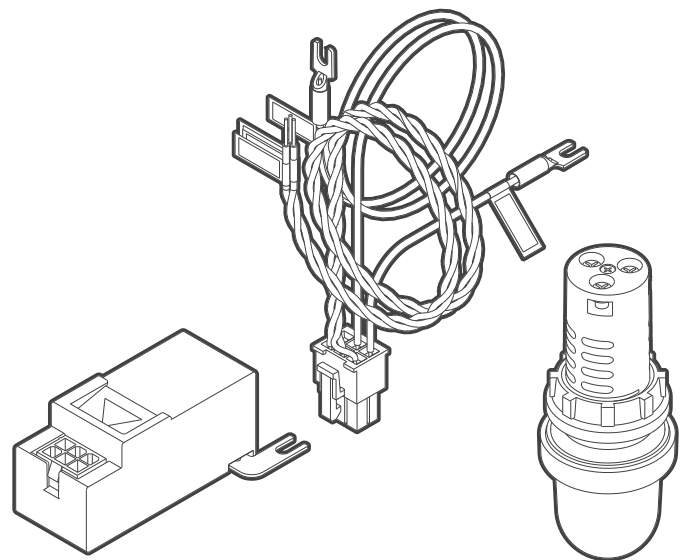

## A2C-LEDKT

► *Estimated launch date: Quarter 4, 2019*

This external status light for ACC2 controllers allows maintenance personnel to know controller status, even with the door closed and locked.

- Easy, low-voltage installation through bottom conduit holes in controller cabinet
- Triple mode light shows Normal/Alarm/Power Outage at a glance
- Operates via controller's Conditional Response "SOS" feature

### A2C-LEDKT MODELS

Model	Description
A2C-LEDKT	ACC2 alarm output light kit

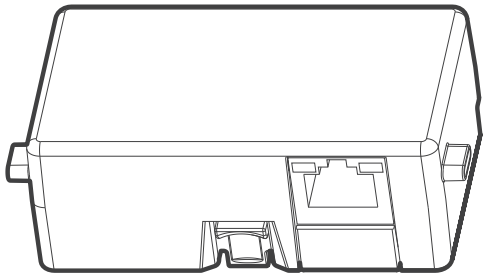

## ACC2 NETWORKING MODULES

► *Estimated launch date: Quarter 4, 2019*

Add Centralus web-based management via Wi-Fi or LAN (Ethernet) to industry-leading ACC2 commercial controllers with these flexible, low-cost internal modules.

- Simple plug-in installation to controller panel
- A2C-WIFI now allows wireless 2.4 GHz connectivity for Centralus central control (antenna included)
- A2C-LAN allows Ethernet hardwired connectivity for Centralus central control (RJ-45 receptacle)
- Uses network internet access for Centralus management and control

ACC2 NETWORKING MODELS	
Model	Description
A2C-WIFI	ACC2 Wi-Fi module with antenna
A2C-LAN	ACC2 Ethernet (LAN) module



## ACC-P2P-LTE/ACC-COM-LTE

► *Estimated launch date: Quarter 4, 2019*

Enable new cellular communications for original ACC controllers with up-to-date LTE or international data connections.

- Easily installs in the controller facepack frame (antennas included, provision for external antenna mounting available)
- Allows LTE communications (North America) or other services for international needs
- Built-in status and setup display

ACC-P2P-LTE/ACC-COM-LTE MODELS	
Model	Description
ACC-P2P-LTE	ACC LTE cell module, single controller, North America
ACC-COM-LTE	ACC LTE cell module, multi-controller, North America
ACC-COM-LTE-E	ACC LTE cell module, multi-controller, international



# Hunter® UNIVERSITY

## **GROW AND LEARN** with Hunter and FX Luminaire

*Discover Your Path to Success* The following training programs are located on the Hunter online training website under the Certificate Programs drop-down menu.

### Hunter UNIVERSITY | **PRODUCT** TECHNICIAN

This program walks you through the basics of irrigation products, from controllers and valves to sprays and rotors. You will understand what products to use for specific situations, and you will learn the value of each product. *Also available in Spanish.*

### Hunter UNIVERSITY | **IRRIGATION** DESIGNER

Learn the fundamental steps of creating an irrigation design, including layout, hydraulics, and product selection.

### Hunter UNIVERSITY | **ACC and TWO-WIRE** SPECIALIST

ACC controllers provide a range of advanced features. Learn how to install, program, and troubleshoot conventional and two-wire ACC systems.

### Hunter UNIVERSITY | **HYDRAWISE®** SPECIALIST

Wi-Fi technology is changing homeowner expectations about irrigation controllers. Find out all you need to know about Wi-Fi installation, weather stations, smart home integration, contractor tools, and more.

### Hunter UNIVERSITY | **LIGHTING** DESIGNER

This program features expert lighting designers who reveal how they design properties using different techniques. This is a great way to learn about the art and science of lighting design and the products that provide desired effects.

### *Schedule a Training Session*

We offer an array of online and in-person workshops, so you can stay on top of the latest products and techniques.

If you are interested in attending, use the links below to find a scheduled workshop or let us know the topics and dates you're interested in. We'll work with you to schedule a training.

### **Contact Sales to Set Up an Appointment**

[hunter.direct/sales](http://hunter.direct/sales)

### **Upcoming Scheduled Training**

To view dates for upcoming workshops, visit [training.hunterindustries.com](http://training.hunterindustries.com).



Helping our customers succeed is what drives us. While our passion for innovation and engineering is built into everything we do, it is our commitment to exceptional support that we hope will keep you in the Hunter family of customers for years to come.

A handwritten signature in white ink, appearing to read 'G.R. Hunter', is positioned above the name.

Gregory R. Hunter, CEO of Hunter Industries

A handwritten signature in white ink, appearing to read 'Gene Smith', is positioned above the name.

Gene Smith, President, Landscape Irrigation and Outdoor Lighting

**Website** [hunterindustries.com](http://hunterindustries.com) | **Customer Support** +1 800-383-4747 | **Technical Service** +1 800-733-2823

This brochure was printed on Forest Stewardship Council® (FSC®) certified paper with soy inks. The FSC is an international organization established to promote the responsible management of the world's forests.



Printed using  
100% Wind  
Energy, (RECs)



© 2019 Hunter Industries Incorporated. Please recycle A small recycling symbol consisting of three chasing arrows forming a triangle.

RC-001-BR US 10/19

Hunter, the Hunter logo, and all other trademarks are property of Hunter Industries, registered in the U.S. and other countries.