

# What's New 2021

**Hunter®**

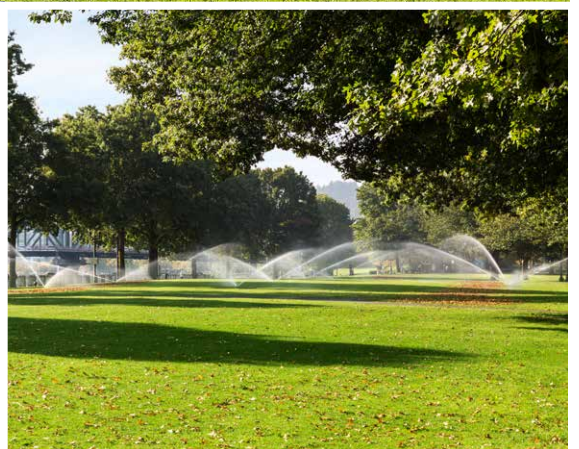

# To Our Valued Customers

## A PROMISE OF PARTNERSHIP

We are excited to recap our latest innovative landscape irrigation solutions and give you a sneak peek at all the new products we have coming to you very soon. One thing that is not new, however, is our commitment to you as a partner. **Customer satisfaction remains one of our most important core values. We are not successful unless you are successful.** Throughout 2020, we faced many challenges to this partnership, including the global pandemic and an unprecedented surge in demand that severely challenged our supply chain and logistics pipelines. We are proud of how quickly our internal and external teams pivoted to provide customers around the world with essential tools and training using remote technologies to replace in-person support. We are equally proud of our success in keeping manufacturing and logistics employees safe while weathering the worst of the crisis and returning to full production. Hunter has emerged stronger and better able to support your future needs.

To help support you in strengthening your business, we have made significant investments in tools and training. You will see an overview of the many free tools, apps, calculators, guides, videos, and training courses developed with you in mind. Usage of these tools surged in 2020, which tells us that we are providing what the market needs. Despite challenges posed by the pandemic, we made significant investments in these technologies to provide you with the best tools in the industry

**Lastly, thank you for your role in our partnership and trust in Hunter. We hope to return to more in-person support in 2021.**

Sincerely,



Gene Smith

President, Landscape Irrigation and Outdoor Lighting

# Table of Contents

- | 2020 PRODUCT HIGHLIGHTS 4
- | PROFESSIONAL TOOLS 6
- | CENTRALUS™ SOFTWARE UPDATES 8
- | HYDRAWISE® SOFTWARE UPDATES 9
- | WIRELESS HC FLOW METER 9
- | PRO-C® DECODER MODULE 10
- | EZ-DT DIAGNOSTIC TOOL 10
- | PRO-C EXPANSION MODULE 11
- | ROAM XL ANTENNA KIT 11
- | PGP-06 ROTOR 12
- | SRM-04 ROTOR 13
- | STG-900-KIT FOR ST SYSTEMS 14
- | ST-1600-KIT FOR ST SYSTEMS 15
- | I-25 NOZZLES 16
- | HSBE FITTINGS 16
- | MP STAKE ACCESSORY 17
- | MPE MULTIPOINT EMITTERS 18
- | HDL-COP DRIPLINE 18
- | MICRO MERCHANDISING 19



# 2020 Product Highlights

From powerful rotors that push the limits of engineering to the latest water-saving irrigation control solutions, we are proud to be at the forefront of innovation in every product that we manufacture. Check out some recent additions to our product family in 2020.



## I-50 ROTOR

With a radius range of 44 to 76', the I-50 large turf rotor is built to conquer demanding environments. The robust, planetary gear drive offers the highest torque output on the market to push past poor water conditions that can cause clogging. A powerful drive mechanism derived from Hunter's time-proven golf rotors ensures top performance in any application.



## PR-075 PRESSURE REGULATOR

Easily installed on PGP® and I-20 rotors, the PR-075 pressure regulator reduces high incoming pressures of 50 to 100 PSI. The PR-075 allows nozzles to operate at peak efficiency, saving up to 25% more water while preventing overspray onto hardscapes and adjacent areas.



## PGP-00-PRB & I-20-00-PRB ROTORS

The PGP-00-PRB and I-20-00 pressure-regulated shrub rotors reduce high incoming pressures of 50 to 100 PSI. Pressure regulation allows nozzles to operate at peak efficiency, saving up to 25% more water.



## HY FILTERS

Ideal for any large commercial job, Hunter 1½" and 2" oversized HY filters are built with glass-filled polypropylene to ensure maximum longevity, maintain low friction loss, and provide a high-pressure threshold. They come standard with either a 150-mesh screen or 125-micron disc.



## NODE-BT CONTROLLER

NODE-BT is enabled with powerful wireless technology that can be easily managed from a smartphone up to 50' away. Install the waterproof NODE-BT in highway landscapes, parks, green roofs, temporary irrigation sites, or other outdoor applications where AC power is unavailable.



## X2™ CONTROLLER WITH WAND

X2 brings irrigation management into the next generation by providing the option to add advanced water-saving features using Hunter's industry-leading wireless Hydrowise technology. Upgrade to the Hydrowise platform with the simple, add-on WAND Wi-Fi module.

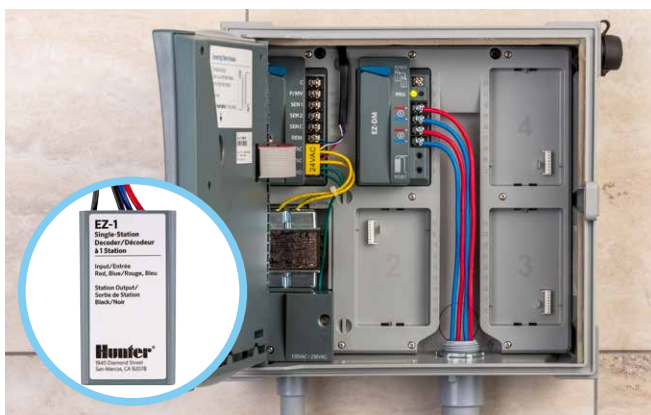

## EZ DECODER SYSTEM

Bring two-wire technology to more projects than ever before with the revolutionary, low-cost, hassle-free EZ Decoder System. Compatible with HCC, ICC2, (and now!) Pro-C controllers, EZDS enables two-wire control at a fraction of the traditional cost.



## HDL-PC DRIPLINE

High-efficiency Hunter Dripline (HDL) is an ultra-durable upgrade to PLD. With built-in pressure compensation for uniform flow and consistent coverage, HDL-PC effectively irrigates shrubs, gardens, turf, and trees in at-grade and subsurface installations. Color-coded striping allows users to quickly identify the flow in the field.

# Powerful Tools TO GROW YOUR BUSINESS

We offer a full range of online resources to help you work smarter, support your customers, and get more product knowledge — **for free!**



SiteRec App



Run Time Calculator

## Tools for Irrigation Professionals

### SITEREC APP

Close sales faster! Built-in videos and product comparisons help you show the value of a better products and confidently present irrigation system recommendations to your customers. Add your company logo and business details for a professional presentation.

[hunter.direct/siterec](https://hunter.direct/siterec)

### DRIPLINE CALCULATOR

Eliminate guesswork and mistakes with this handy tool. See product recommendations, get project quantities, and calculate run times in a simple format. Download the Hunter Dripline Calculator from the App Store® or Google Play™ today.

[hunter.direct/dripcal](https://hunter.direct/dripcal)

### RUN TIME CALCULATOR

Use this helpful calculator to generate the most efficient irrigation schedule for every landscape and prevent wasteful runoff.

[hunter.direct/runtime](https://hunter.direct/runtime)

### WATER SAVINGS CALCULATOR

Show your customers how much water — and money — they can save by upgrading to a more efficient irrigation system.

[hunter.direct/savingscal](https://hunter.direct/savingscal)

App Store is a service mark of Apple Inc., registered in the U.S. and other countries. Google Play is a trademark of Google LLC.





My List

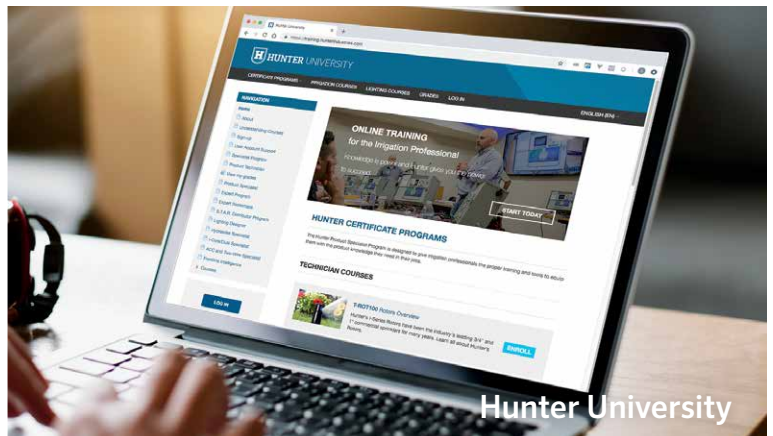

Hunter University

## Tools for Irrigation and Lighting Professionals

### MY LIST

Build customized product lists for every irrigation and lighting project. Email your lists to distributors for faster ordering and add cut sheets, list pricing, and notes to each project.

[hunter.direct/mylist](https://hunter.direct/mylist) | [fxl.com/mylist](https://fxl.com/mylist)

### PRODUCT SUPPORT INFORMATION

- Technical guides
- CAD details
- Photo library
- Product guides
- Brochures



Advance your career with comprehensive online training certificate programs for irrigation and lighting professionals. From general product knowledge to advanced control systems and design techniques, there is a program waiting for you!

[training.hunterindustries.com](https://training.hunterindustries.com)

### CUSTOM MARKETING MATERIALS

- Door hangers
- Yard signs
- Truck magnets
- Postcards
- Email templates

Access these tools and more at: [hunter.direct/tools](https://hunter.direct/tools) | [fxl.com/tools](https://fxl.com/tools)

# Centralus Updates

Enable advanced cloud-based control and water-saving features for ICC2 and ACC2 controllers with the mobile-friendly Centralus platform.

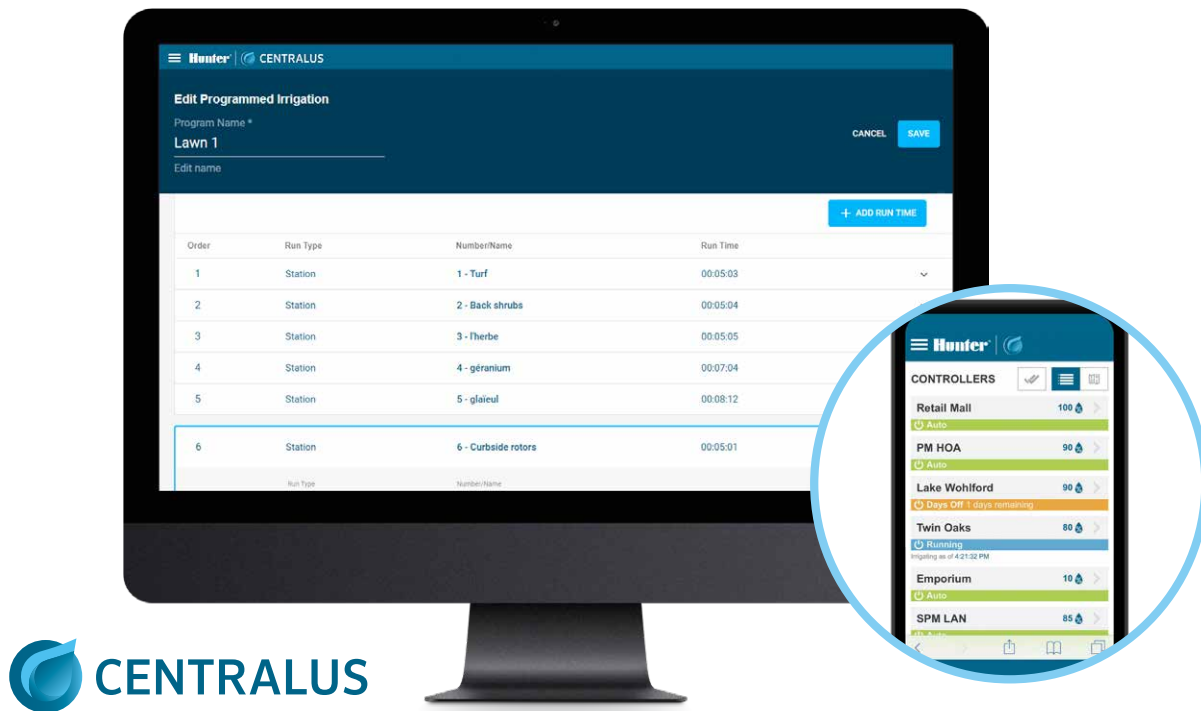

## New and Enhanced Software Features

- **Scheduling enhancements**
  - **Full Run Time** editing capabilities (by Station/Block/Interval, in hours:minutes:seconds)
  - **Conflict Detection** identifies and reports changes in field hardware configuration
- **Cellular connection** (monthly data plan required), in addition to Wi-Fi and LAN
- **Enhanced remote capabilities**, including water days, start times, and run time adjustments
- **Highly secure** cloud access
- **Map-based navigation** and status
- **Instant remote control** from mobile device
- **Flow monitoring** and reporting
- **Alarm reports** and detailed irrigation history reports with mobile text alerts
- **Crew management** functions

### COMMUNICATION MODELS

Model	Description
WIFIKIT	ICC2 Wi-Fi connection module
LANKIT	ICC2 LAN connection module
A2C-WIFI	ACC2 Wi-Fi module for Centralus
A2C-LAN	ACC2 Ethernet (LAN) module for Centralus
A2C-LTE*	ACC2 cellular connection module, North America

\*Requires monthly service plan



# Hydrawise Updates

To help contractors grow their business, Hydrawise continuously adds new customer service and water management features.

## New and Enhanced Software Features

- **Suspension by dates** to cancel irrigation for upcoming events
- **Watchlist tool** to easily view and manage key customers
- **Controller sort feature** organizes controllers alphabetically, by last used, and closest to your location
- **Additional sensor activity** alerts
- **Water History Report** and **Water Forecast Report** so contractors can help their customers better understand how water is being used
- **Grow-In Programs** tool allows flexible start and end dates to accommodate newly established plants

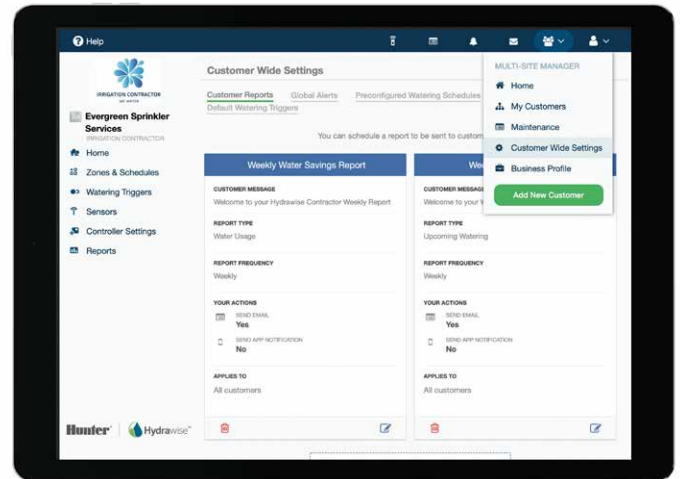

### WIRELESS HC FLOW METER SENSOR

► *Estimated launch date: Q4 2020*

Add powerful, wireless flow-monitoring capabilities to Hydrawise systems with this simple and affordable kit.

- **Compatible with Hydrawise enabled HC, HPC, Pro-HC, and HCC controllers only**
- Sends station-level flow rates and flow totals from the sensor to the controller wirelessly, without the need to dig trenches or run wire
- Provides 500' line-of-sight communication from transmitter to receiver

#### WIRELESS HC FLOW METER MODELS

Model	Description
W-HC-FLOW	Wireless HC Flow Meter Kit (domestic 900 MHz) includes transmitter and receiver
W-HC-FLOW-TR	Wireless HC Flow Meter transmitter only (domestic 900 MHz)
W-HC-FLOW-R	Wireless HC Flow Meter receiver only (domestic 900 MHz)
HC-075-FLOW	HC Flow Meter with ¾" NPT thread, U.S. gallons
HC-100-FLOW	HC Flow Meter with 1" NPT thread, U.S. gallons
HC-150-FLOW	HC Flow Meter with 1½" NPT thread, U.S. gallons
HC-200-FLOW	HC Flow Meter with 2" NPT thread, U.S. gallons

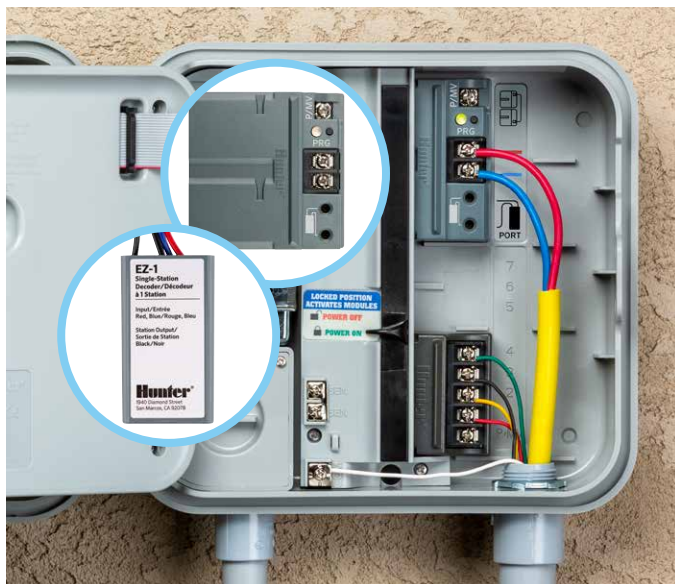

## PRO-C CONTROLLER DECODER MODULE

► Launched: June 2020

Bring revolutionary Hunter EZ Decoder technology to residential and light commercial projects with the PC-DM decoder module for Pro-C controllers. This simple and affordable plug-in module enables two-wire control without the need for special wire, connectors, in-line grounding, or surge arrestors

- Increase station counts:
  - Two-wire only: 28 stations
  - Hybrid conventional and two-wire: 32 stations
- For use with Hunter EZ-1 decoders only; wire paths possible over 3,000'
- Electrical output on two-wire path:  
24 VAC, 50/60 Hz

PRO-C MODULE MODELS	
Model	Description
PC-DM	EZ Decoder output module for Pro-C controller
PC-DM-KIT	Upgrade kit for EZ Decoder output module, includes compatible facepack



## EZ-DT WIRELESS DIAGNOSTIC TOOL

► Estimated launch date: Q1 2021

Simplify maintenance of EZ Decoder systems with this handheld, wireless diagnostic tool.

- Reads status, station number, and more with wireless connection
- SD card with flash update capability
- Simple system diagnostics and troubleshooting without the need to remove decoders from the two-wire path
- Diagnose performance issues quickly and easily
- EZ Decoder station programming via wired connection only
- Operates on 4 x AAA batteries

EZ-DT MODELS	
Model	Description
EZ-DT	Wireless diagnostic tool for EZ Decoder system



### PRO-C CONTROLLER EXPANSION MODULE

► Launched: June 2020

**Add more stations to the Pro-C controller than ever before.** With the PCM-1600 output module, there is no need to replace the controller to add more zones.

- 16-station output module (PCM-1600) enables conventional control for up to 23 stations
- Built-in surge protection for improved reliability and durability in lightning-prone areas
- Compact and affordable solution for residential and light commercial projects

PRO-C EXPANSION MODULE MODELS	
Model	Description
PCM-1600	16-station plug-in module for Pro-C controller
PCM-1600-KIT	Upgrade kit for 16-station plug-in module, includes compatible facepack



### ROAM XL ANTENNA EXTENSION KIT

► Launched: June 2020

**Enable professional, license-free remote control for projects of any size with this long-range remote and antenna extension kit.**

- Quickly and easily extend the receiver antenna location for any existing or new installation ROAM XL system
- Improve line-of-sight communication between transmitter and receiver (2-mile range)
- Avoid obstructions and RF interference with this flexible mounting option

ROAMXL ANTENNA EXTENSION KIT MODELS	
Model	Description
ROAMXL-KIT	Transmitter, receiver, SmartPort® wiring harness, 4 AAA batteries, and plastic carrying case included
ROAMXL-TR	Handheld transmitter and 4 AAA batteries included
ROAMXL-R	Receiver unit (SmartPort wiring harness included)
ROAMXL-EXT	ROAM XL antenna extension kit with 25' cable





## PGP-06 ROTOR

► *Estimated Launch Date: Q4 2020*

The PGP-06 rotor completes the high-performance PGP Ultra rotor lineup. PGP Ultra models are now available for use on risers, short turf, tall turf, and tall groundcover.

### Key Benefits

- 6" pop-up clears taller turf to ensure the nozzle can operate effectively and unimpeded
- Patented automatic arc return feature returns the turret back to the original arc pattern if vandalized; adjustable arc from 50° to 360°
- Non-strippable drive mechanism is protected from damage if turned in the opposite direction of travel
- Part- and full-circle in one model for flexibility across landscapes and reduced inventory
- Headed and slotted setscrew allows simple radius adjustments in the field with a Hunter wrench or flat-head screwdriver

### Operating Specifications

- Nozzle choices: 34
- Radius: 17 to 46'
- Flow: 0.36 to 14.8 GPM
- Recommended pressure range: 25 to 70 PSI
- Operating pressure range: 20 to 100 PSI
- Precipitation rate: 0.4 in/hr approximately
- Nozzle trajectory: standard = 25°, low angle = 13°
- Nozzle racks: 1.5 to 8.0 blue, 2.0 to 4.5 low angle gray, 0.50 to 3.0 black, 6.0 to 13.0 green, MPR-25, MPR-30, MPR-35
- Warranty period: 5 years

### PGP-ULTRA - SPECIFICATION BUILDER: ORDER 1 + 2 + 3 + 4

1 Model	2 Standard Features	3 Feature Options	4 Nozzle Options
<b>PGP-00</b> = Shrub <b>PGP-04</b> = 4" pop-up <b>PGP-06</b> = 6" pop-up <b>PGP-12</b> = 12" pop-up	Adjustable arc, plastic riser, 8 standard nozzles, and 4 low-angle nozzles	<b>CV</b> = Drain check valve <b>CV-R</b> = Drain check valve, and reclaimed water ID	<b>Blue</b> = 1.5-8.0 <b>Grey low-angle</b> <b>Black short-radius</b> <b>Green high-flow</b> <b>MPR-25-Q, T, H, F</b> <b>MPR-30-Q, T, H, F</b> <b>MPR-35-Q, T, H, F</b> <b>1.5 to 4.0</b> = Only nozzles 1.5-4.0 can be factory-installed

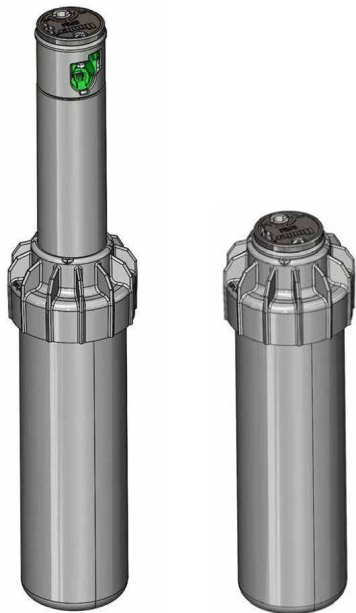

## SRM-04 ROTOR

► *Estimated launch date: Q1 2021*

The new SRM-04 is an updated version of the field-proven SRM rotor. Designed with a complete makeover, the SRM-04 has solidified its position in our lineup as an excellent entry-level, cost-competitive rotor.

### Key Benefits

- With innovative 5:1 functionality, it's easier to fine-tune the edges of the arc pattern
- New headed and slotted screw is more convenient to access and use
- Choose from eight nozzles, including two popular new additions, the 2.5 and 4.0
- Simple to retrofit into existing SRM bodies

### Operating Specifications

- Nozzle choices: 8
- Radius: 15 to 34'
- Flow: 0.42 to 4.3 GPM
- Recommended pressure range: 30 to 50 PSI
- Operating pressure range: 20 to 100 PSI
- Precipitation rate: 0.6 in/hr approximately
- Nozzle trajectory: approximately 14°
- Warranty period: 2 years

SRM-04 MODEL	
Model	Description
SRM-04	4" pop-up, adjustable arc, 8 standard nozzles

## Complete Synthetic Turf Irrigation Kits for Simple Design and Ordering



### STG-900-KIT IRRIGATION KIT FOR SMALL TO MIDSIZE ST APPLICATIONS

► Reintroduction: Q1 2021

Designed for smaller field layouts, the STG-900 rotor provides a cost-competitive solution for radius ranges up to 120'. For added flexibility, the rotor can be installed in a vault system located within the synthetic field.

#### Key Benefits

- Order the complete kit or create a customized configuration
- For cleaning, cooling, and flushing synthetic fields for play
- Water-lubricated gear drive for highly reliable operation without clogging
- QuickCheck™ arc mechanism for easy verification of arc setting
- Optional rubber cover for added safety on the field

#### Operating Specifications

- Radius: 103 to 120'
- Flow: 74.5 to 92.0 GPM
- Operating pressure range: 100 to 120 PSI

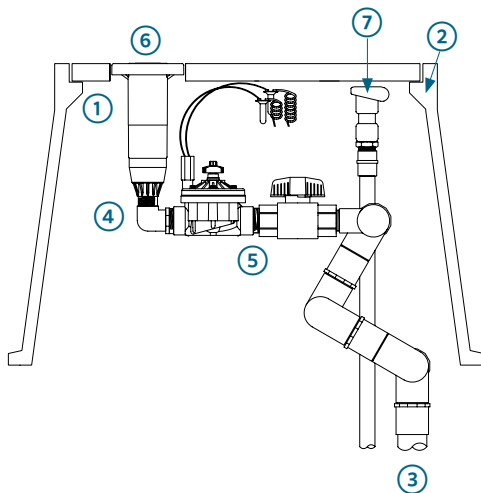

#### STG-900-KIT SYSTEM COMPONENTS

1	STG-900-83	Synthetic turf rotor
2	ST-173026-B	Vault
3	ST-2008-VA	Multi-axis vertical alignment swing joint
4	239800	1 1/2" female Acme x male Acme fitting
5	ST-VBVF-K	Valve kit
6	473900SP	Rubber cover
7	HQ-5RC	Quick coupler 1" inlet with 1 1/4" outlet for key





## ST-1600-KIT IRRIGATION KIT FOR LONG-RANGE ST APPLICATIONS

► Reintroduction: Q1 2021

**Engineered with a spacious vault system, the ST-1600 rotor is the premium solution for synthetic turf irrigation.**

With a powerful throw radius up to 165', the ST-1600 is the most reliable gear-driven synthetic turf rotor on the market. It offers seamless installation and includes a construction-grade fiberglass shell for easy servicing of all components.

### Key Benefits

- **Order the complete kit or create a customized configuration**
- For cleaning, cooling, and flushing synthetic fields for play
- Isolated, grease-lubricated gear drive for consistent top performance
- Ratcheting nozzle turret and flexible arc adjustment for simple setup
- Corrosion- and impact-resistant body for maximum durability in tough environments

### Operating Specifications

- Radius: 107 to 165'
- Flow: 96.2 to 326.8 GPM
- Operating pressure range: 60 to 120 PSI

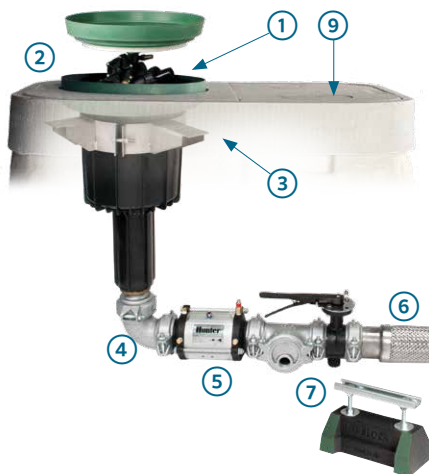

### ST-1600-KIT SYSTEM COMPONENTS

1	ST-1600-HSB	Synthetic turf rotor
2	ST-243636-B	Vault
3	ST-BKT-1600	Bracket for rotor
4	ST-BVF30-K	Manifold, including 3" fittings, isolation valve, drain valve
5	ST-V30-KV	3" low-pressure-loss metal valve, including on-off-auto selector and solenoid
6	ST-H30-K	Flexible stainless steel alignment hose.
7	ST-SPT-K*	Adjustable manifold support
8	ST-IBS-1600	Rubber cover kit with infill barrier system
9	HQ-5SRC	Quick coupler 1" inlet with 1 1/4" outlet for key

\* Two required for installation



## I-25 NOZZLES

► Launched: Q2 2020

The popular 1" I-25 rotor now accommodates a full range of easier-to-install nozzles! With the same high-efficiency performance as the previous nozzles, the redesigned nozzles have large, easy-grip surfaces for simple insertion into the nozzle housing. The nozzles are retrofittable to I-25 rotors that are up to 25 years old!

- 11 color-coded nozzle choices, available factory-installed or as parts
- Easily installs in all models of I-25 rotors
- Designed for large turf applications

### Operating Specifications

- Radius: 37 to 71'
- Flow: 3.8 to 31.5 GPM
- Precipitation rates: 0.4 in/hr appx
- Nozzle trajectory: standard = 25°

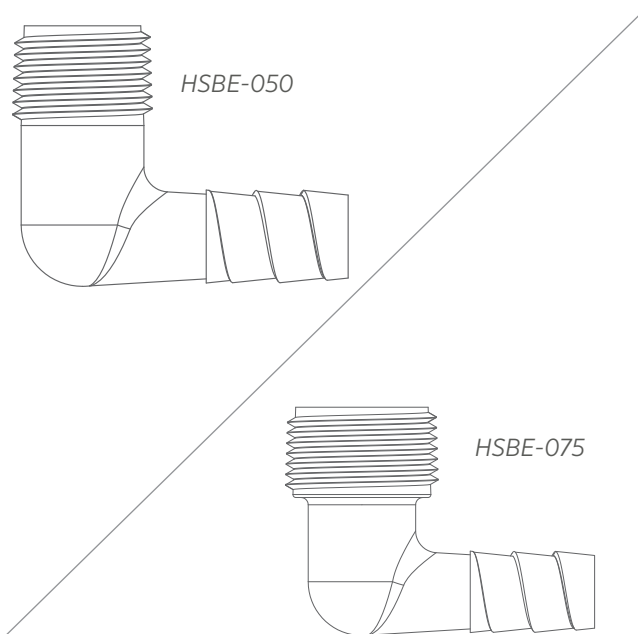

## HSBE FITTINGS

► Estimated launch date: Q1 2021

Redesigned Hunter Spiral Barb Elbows create robust, customized swing joints for new installations and existing system maintenance. With an updated and innovative spiral-to-sealing barb design, HSBE fittings are easy to install in any setting.

- Robust design for long-lasting reliability
- Larger barb for better sealing
- Acetal material for a sharp spiral barb and sealing barb
- Compatible with Hunter FlexSG and other brands for a customized swing join.

### HSBE MODELS

Model	Description
HSBE-050	1/2" male x spiral barb elbow
HSBE-075	3/4" male x spiral barb elbow



## MP STAKE ACCESSORY

► *Estimated Launch Date: Q4 2020*

Designed for use with high-efficiency MP Rotator® nozzles, the MP Stake accessory is a convenient solution for temporary irrigation applications including native plant restoration, plant establishment, and nurseries.

### Key Benefits

- Pre-assembled staking kit for fast and easy installation in any environment
- Includes a durable 26" stake, 0.345" tubing, 1/2" male fitting for connection, and nozzle adapter
- For maximum water efficiency, add an optional 40 PSI pressure regulator and Hunter Check Valve

### Operating Specifications

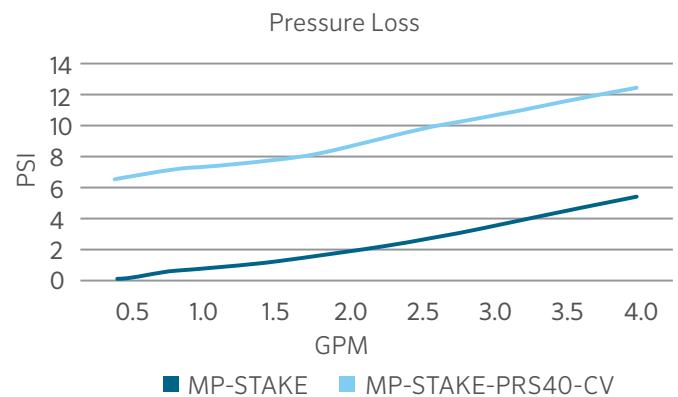

MP-STAKE MODELS	
Model	Description
MP-STAKE	26" staking kit, 0.345" tubing to 1/2" male fitting, PROS-00 shrub (total height: 28")
MP-STAKE-PRS40-CV	26" staking kit, 0.345" tubing to 1/2" male fitting, Hunter Check Valve, PROS-00-PRS40 pressure-regulated shrub adapter (total height: 34")





## MPE MULTIPOST EMITTERS

► Launched: July 2020

MPE emitters with new directional swivels provide consistent flow for mixed plantings, groups of plants, or other sparse plantings.

- Swivel elbows allow the flow to be precisely targeted in a specific direction
- Unused outlets can be capped with PVC cap plugs
- All ports have built-in pressure compensation for maximum efficiency
- Earth-tone color-coding to show the flows of 0.5, 1.0, 2.0, or free-flowing manifold

MPE MODELS	
Model	Description
MPE-05	Blue = 0.5 GPH
MPE-10	Black = 1.0 GPH
MPE-20	Red = 2.0 GPH
MPM-050	Gray = Unrestricted

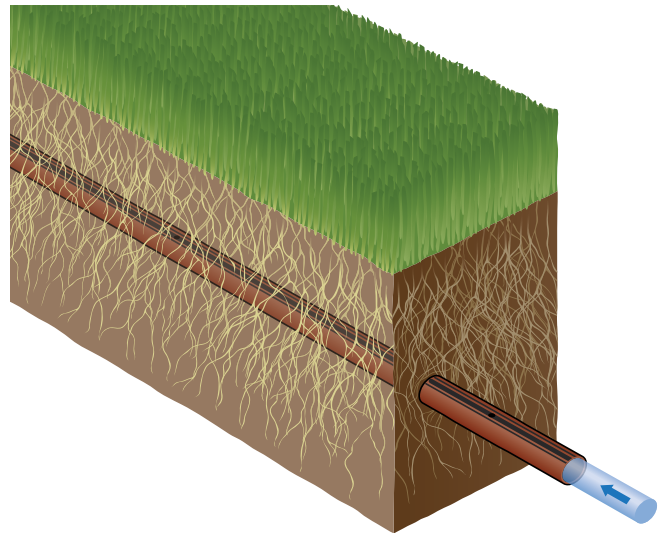

## HDL-COP DRIPLINE

► Estimated launch date: Q1 2021

Minimize the risk of root intrusion by adding copper to industry-leading Hunter Dripline. New HDL-COP is the perfect complement to the field-proven Hunter family of at-grade and subsurface products: HDL-PC, HDL-CV, HDL-R, Eco-Wrap®, and Eco-Mat®. HDL-COP comes with the same robust design elements of HDL-CV, with the added benefit of copper in the emitter to assist in preventing root intrusion.

- Copper oxide in the emitter provides root intrusion resistance and will not leach into the soil
- Slow-draining check valve stops low-point drainage
- Anti-siphon technology prevents the suction of debris into the emitter that can cause clogging
- With stretch-wrapped coils, the dripline is quick to uncoil and easy to store

HDL-COP MODELS	
Model	Description
HDL-09-12-250-COP	Hunter Dripline CV with copper, 0.9 GPH, 12", 250' coil
HDL-09-12-1K-COP	Hunter Dripline CV with copper, 0.9 GPH, 12", 1,000' coil
HDL-06-12-250-COP	Hunter Dripline CV with copper, 0.6 GPH, 12", 250' coil
HDL-06-12-1K-COP	Hunter Dripline CV with copper, 0.6 GPH, 12", 1,000' coil

# Micro Tough Merchandising

New micro irrigation packaging and in-store displays are now available to help attract attention to Hunter's complete line of solutions, drive customer engagement and sales, and reinforce Hunter as a premium partner backed by high quality and innovation.



**Color-coded labels and trays** ensure seamless product grouping and make similar products easy to find.



**Restocking is fast** and stays organized with display trays conveniently included in the product box.



**Shelf strips and a poster** provide a clean, modern look and clearly present system-level solutions.



**Reordering is easier** with bar codes on each tray and a quick-reference guide for micro irrigation products.

## Complete Micro Irrigation Solutions

### SOFT PIPE SYSTEMS

Using soft pipe to distribute irrigation water is common in both commercial and residential applications. Hunter offers a full suite of products that are compatible with soft pipe systems.

### HARD PIPE SYSTEMS

From multi-port emitters to micro sprays, Hunter offers a wide variety of products and accessories designed to complement the durability of hard pipe systems.

### DRIPLINE SYSTEMS

Ultra-durable Hunter Dripline (HDL) is easy to install and works efficiently and effectively to keep plants thriving. Hunter provides all necessary components to create a complete dripline system.



Helping our customers succeed is what drives us. While our passion for innovation and engineering is built into everything we do, it is our commitment to exceptional support that we hope will keep you in the Hunter family of customers for years to come.

A handwritten signature in white ink, appearing to read 'G.R. Hunter', is written over a light blue background.

Gregory R. Hunter, CEO of Hunter Industries

A handwritten signature in white ink, appearing to read 'Gene Smith', is written over a light blue background.

Gene Smith, President, Landscape Irrigation and Outdoor Lighting

**Website** [hunterindustries.com](http://hunterindustries.com) | **Customer Support** +1 800-383-4747 | **Technical Service** +1 800-733-2823

This brochure was printed on Forest Stewardship Council® (FSC®) certified paper with soy inks. The FSC is an international organization established to promote the responsible management of the world's forests.

© 2020 Hunter Industries™

RC-001-BR US Vol 39 9/20

Hunter, the Hunter logo, and all other trademarks are property of Hunter Industries, registered in the U.S. and other countries. Please recycle.



Printed using  
100% Wind  
Energy, (RECs)

