

ST-1600-KIT and ST-1600-KIT-B

INSTALLATION GUIDE

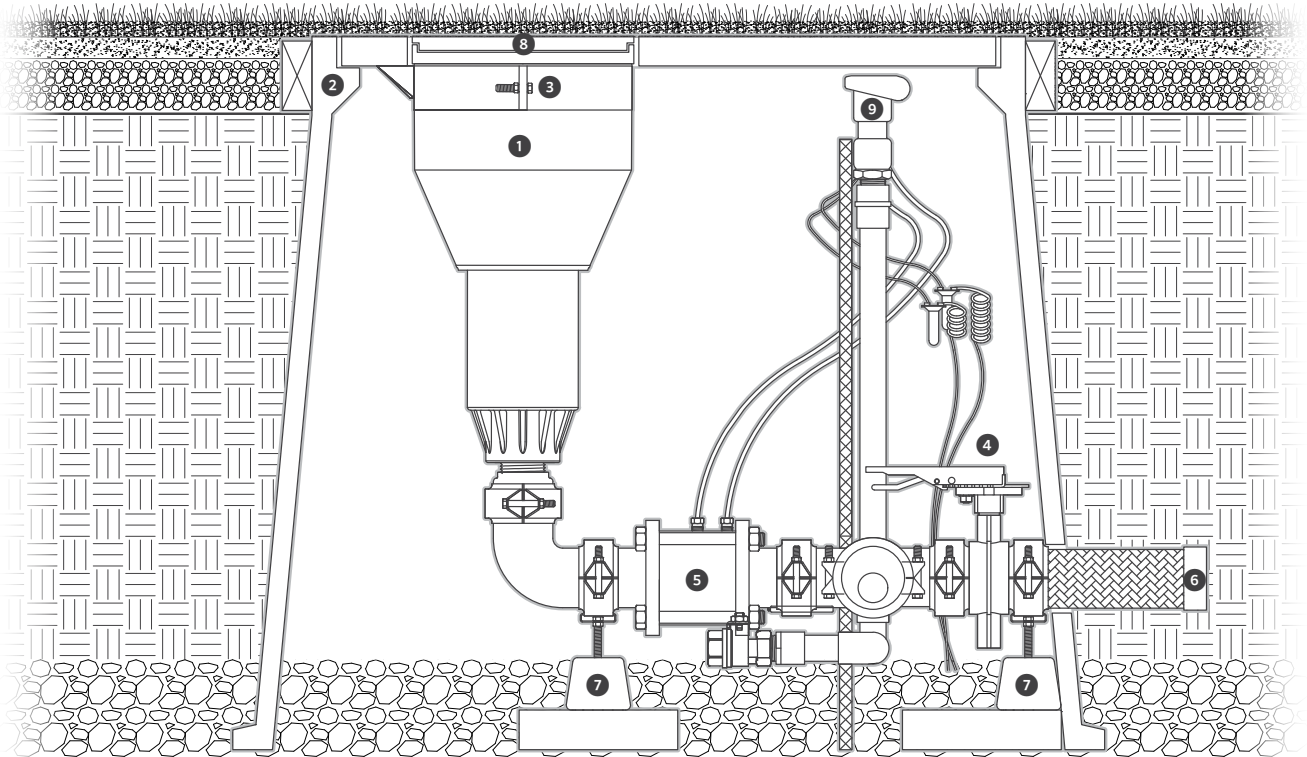

FIGURE	COMPONENT	QTY	DESCRIPTION
1	ST-1600-HS-B	1	High-speed pop-up, adjustable arc (40° to 360°), 2" (50 mm) BSP inlet
2	ST-243636-B	1	Composite vault, pre-cast hole for rotor and two quick-access ports for quick coupler and remote on-off-auto selector
3	ST-BKT-1600	1	Rotor vault hanger and grade adjustment bracket for ST-1600-HS-B rotor
4	ST-BVF30-K	1	Manifold butterfly valve and Victaulic® coupling fitting kit
5	ST-V30-KV	1	3" (80 mm) metal control valve, 3" (80 mm) grooved Victaulic inlet/outlet fittings, solenoid, and on-off-auto selector manifold
6	ST-H30-K	1	Ultra-flexible 3" x 26" (8 cm x 66 cm) stainless steel corrugated manifold inlet hose with stainless steel braided outer support layer with 3" (80 mm) female NPT inlet
7	ST-SPT-K	2	Adjustable manifold support stand; two required per vault
8	ST-IBS-1600	1	Infill barrier system rubber cover kit for ST-1600-HS-B rotor
9	HQ-5RC	1	Quick coupler, 1" (25 mm) NPT inlet, 1¼" (32 mm) outlet for key

ST-1600-KIT and ST-1600-KIT-B Irrigation Systems
For Cooling, Cleaning, and Preparing Synthetic Turf for Play

Hunter®

Install the ST-243636-B Vault in the Desired Location

Configure the vault according to the installation specifications provided by the irrigation consultant. It must rest upon a compacted base material per the field specifications. If the vault is to be set directly upon the gravel within the drainage system, the gravel should be compacted and the vault set upon six or more bricks for stabilization.

The elevation to grade of the vault must be precise. It is determined by the field and irrigation specification. In many installations, the elevation for the vault is specified such that the upper rim of the vault is level with the upper rim of the tack/glue board that surrounds the field. The vault's elevation may also be affected by the type of material, if any, that will be attached to the vault's upper surface. This can include the

field's synthetic "carpet" or the adjacent running track material. Some customers prefer no cover attachments.

When installing the ST-1600-KIT, be aware of the direct and required relationship between the location of the vault, the location of the incoming plumbing, and the location and depth of the drainage system. For the irrigation sprinkler (rotor) to be properly positioned within the hole in the vault's cover set, the inlet piping must be placed at the specified location and depth. In order for the quick coupler valve to be accessible and functional once installed, the quick coupler's supply pipe must be installed in the correct location and the valve must be at the correct height within the vault.

Installation Detail: Turf Over Vault

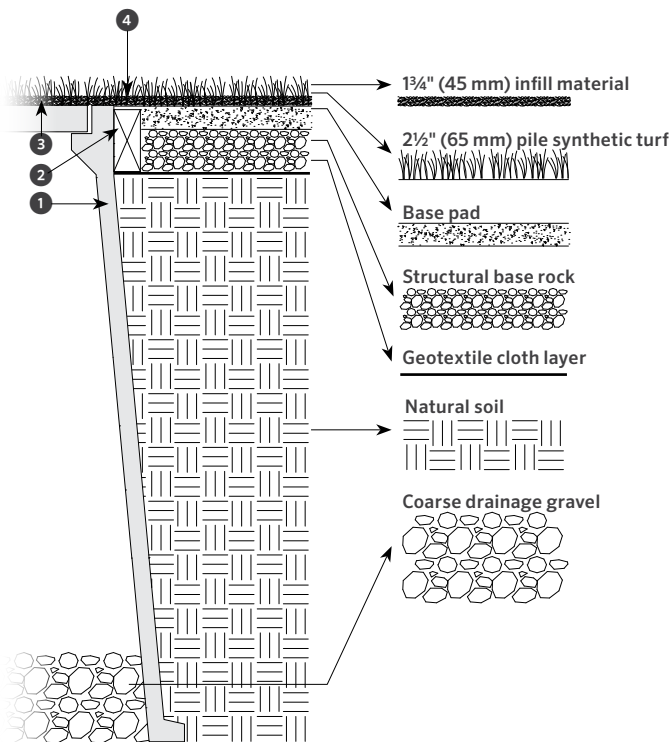

ITEM	DESCRIPTION
1	Vault sidewall and rim
2	2" x 4" (5 cm x 10 cm) tack and glue frame board at field elevation
3	Vault cover
4	Attached synthetic turf to cover, rim, and frame

Installation Detail: Track Over Vault

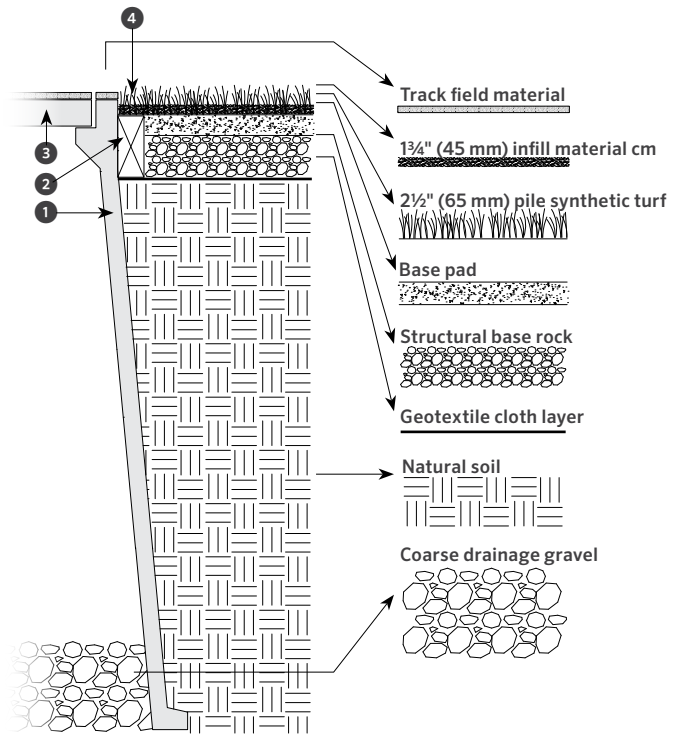

ITEM	DESCRIPTION
1	Vault sidewall and rim
2	2" x 4" (5 cm x 10 cm) tack and glue frame board at field elevation
3	Vault cover
4	Attached synthetic turf to frame

Configure the Location of Incoming Plumbing Lines

For the vault to drain properly, it must be connected to the drainage system, and the drainage system must be lower in elevation than the vault's 36" (91 cm) base. Otherwise, the vault can partially fill with water. Isolating the vault from the drainage could cause the vault to fill with water during heavy precipitation events.

Vault dimensions:

- Upper rim: 27" x 39" (69 cm x 99 cm)
- Cover set: 24" x 36" (6 cm x 91 cm)
- Cover thickness: 3" (80 mm)
- Depth: 36" (91 cm)
- Base: 42" x 48" (107 cm x 122 cm)

Installation Detail: No Turf Over Vault

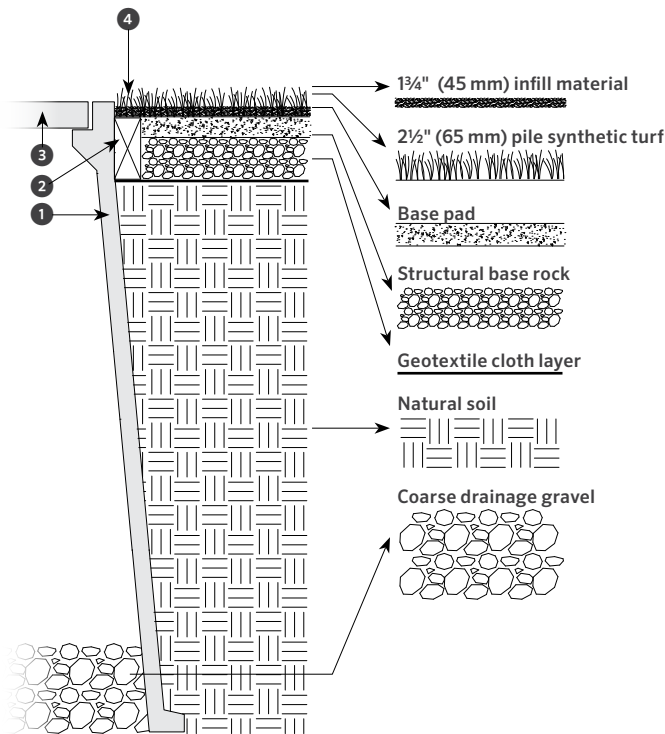

ITEM	DESCRIPTION
1	Vault sidewall and rim
2	2" x 4" (5 cm x 10 cm) tack and glue frame board at field elevation
3	Vault cover
4	Attached synthetic turf to frame

Use the top-view drawing on the following page as a reference when configuring incoming plumbing. The bottom of the top-view drawing represents the on-field side of the vault, while the top of the drawing represents the off-field side. Next, note that the valve manifold inlet is centered along the right side wall of the vault's upper rim. While this is the standard angle for the manifold, the manifold can be pivoted within the vault to adjust for minor angular variances in the rigid submainline piping that will be attached to the manifold.

The quick coupler inlet piping must be plumbed to align with the quick coupler's quick-access port in the vault's cover. Use the top-view illustration on the next page as a reference. The rim of the vault is the exposed upper surface that surrounds the vault's cover set once they are installed. The quick coupler inlet piping must extend vertically to a position directly below the quick-access port (#12) in the vault's cover set. If the quick coupler is too low, it will be impossible to attach the key to the quick coupler.

The depth and location of the rigid piping connected to the inlet of the manifold is critical. Use the side-view drawing of the installation detail on the following page as a reference. Note that the manifold's inlet is 24" to 30" (61 cm to 76 cm) from the top of the vault. Unless otherwise specified, the mainline should also be at this approximate depth.

The quick coupler's inlet piping (#14) must align with the quick coupler access hole in the vault's cover set (#20). For the quick coupler key to operate properly with its handle attached, the quick coupler valve must be installed as near to the underside of the main cover as possible. Use the side-view illustration on the next page as a reference. Install the quick coupler so that the final elevation is approximately 1/2" (13 mm) below the underside of the vault's main cover (#20).

! The pipe size to the manifold must be at least 3" (80 mm) from the mainline through to the manifold assembly.

Product Details

Installation Detail: Top and Side Views

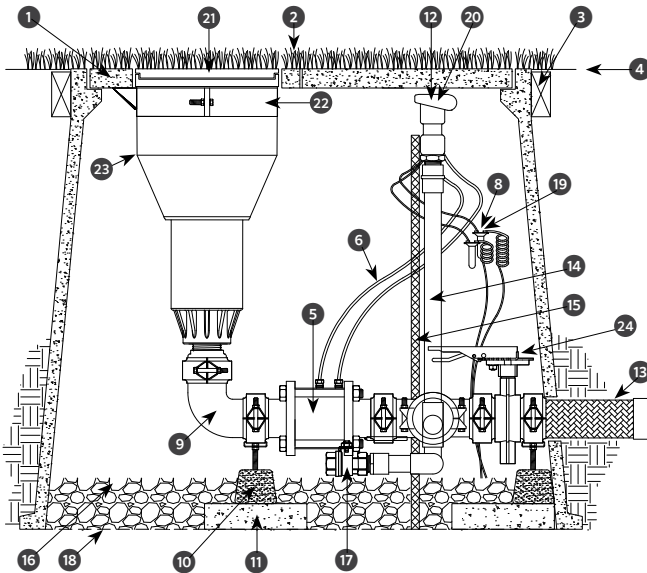
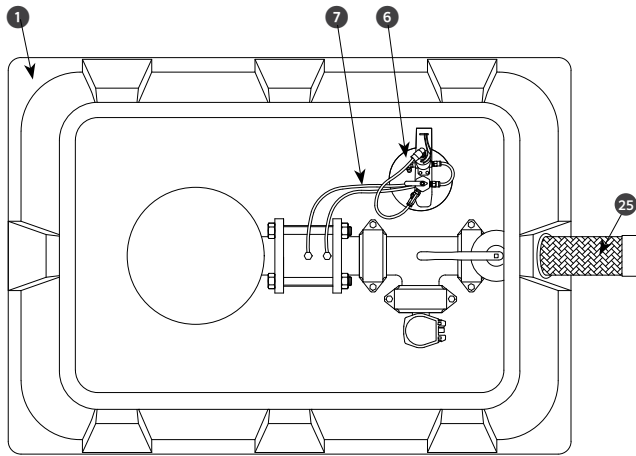

ITEM	DESCRIPTION
1	Hunter ST-243636-B composite vault and four-piece polymer-concrete cover set with cast-in openings to support rotor lateral thrust plus cast-in opening with circular covers for quick coupler and on-off-auto access
2	Synthetic turf or running track material attached to vault rim and cover set (optional)
3	2" x 4" (5 cm x 10 cm) tack/glue board or as per specification of all sides
4	Finished grade set to field perimeter track/glue board or as per specification
5	Hunter ST-V30-KV ultra low loss 3" (80 mm) valve kit with grooved fitting connections
6	Remote on-off-auto selector and solenoid manifold assembly mounted on vault sidewall
7	Color-coded control tubing from ST-V30-KV valve to selector switch mounted on vault side wall
8	Lead wires from solenoid to waterproof splice connectors
9	Hunter STBVF30K isolation valve and fitting kit with grooved connections and 500 PSI (35 bar; 3,500 kPa) rated couplings sufficient to connect rotor and control valve to manifold inlet
10	Hunter STSPTK adjustable manifold support block adjusted to support manifold weight (2)
11	16" x 16" x 2" (40 cm x 40 cm x 5 cm) support pad or concrete stepping stone as per specification (2)
12	Hunter HQ5RC quick coupling valve set directly below circular quick-access port
13	Hunter STH30K 3" (80 mm) stainless steel flexible inlet pipe
14	1" (25 mm) minimum Schedule 80 quick coupler supply piping and fittings or as per specification
15	5/8" x 48" (15 mm x 122 cm) rebar stake with stainless steel strapping
16	Compacted base field materials per specification
17	Brass manual ball valve included/provided with #9 ST-VBF30-K
18	Provide drainage via access to field drainage system
19	Waterproof connections per specifications between control wire and solenoid lead wires
20	Top of quick coupler set less than 1/2" (13 mm) below underside of main vault cover to allow key activation from above
21	Hunter ST-IBS-1600 rubber cover and infill barrier kit with trim reference rings to allow heights from standard 1/4" (32 mm infill application) to flat (non-infill or track material) applications
22	Hunter ST-BKT-1600 rotor hanger and elevation adjustment bracket
23	Hunter ST-1600-HS-B rotor
24	Isolation butterfly valve with grooved connections included; provided with #9 ST-VBF30-K
25	Wrap flexible inlet piping with heavy-duty plastic pipe wrap tape prior to backfill and compaction

Ensure Flexible Hose Access Through the Vault

The vault sidewalls are made with a construction-grade fiberglass material. The manifold and submainline piping are coupled using the flexible stainless steel hose. The flexible hose is designed to adjust for minor elevation and alignment differences between the manifold and submainline piping. The flexible inlet hose replaces the 3" (80 mm) female inlet adapter in the assembly. The mainline service tee location must consider that the ST-H30-K will extend outside the vault by approximately 24" (61 cm). Once the incoming submainline piping and flexible hose location are known relative to the manifold, use a 6" (16 cm) or appropriate-sized hole saw to create an access port in the vault's sidewall. For ease of reference, the ST-H30-K flexible hose has a blue lay line indicator line on the exterior of the hose. This lay line indicator should never appear to be twisted. The lay line should always visually appear as a smooth, untwisted line between the submainline and the manifold. If necessary, adjust the vault position to ensure a smooth, kink-free flexible hose connection from the submainline piping to the manifold. If necessary, loosen the grooved coupling between the flexible hose and the butterfly valve then remove any twist in the flexible hose. Retighten when complete.

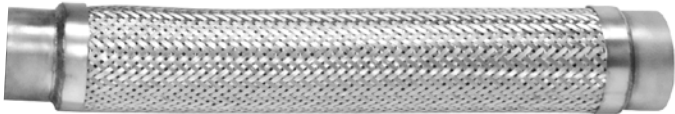

Configure the Rotor, Rotor Hanger Bracket, and Manifold Assembly

The rotor, rotor hanger bracket, and manifold assembly must be assembled prior to lowering these components into the vault. Before lowering this assembly, the concrete support pads and adjustable manifold support stands must be properly positioned.

The rotor hanger bracket is designed to support the weight of the rotor within the vault and provide elevation adjustments for the rotor. The weight of the manifold must be supported by the two adjustable support stands positioned and raised under the manifold assembly.

There are two halves to the adjustable rotor support bracket. The two halves are connected with the supplied bolts and nylock-type nuts. Set the two halves side-by-side with the protruding hanger arms (top side of the brackets) facing upward. Insert the bolts through the bracket holes and attach the nuts. Slide the assembly under the rotor and up under the rotor's flange. Tighten the bolt and nut assemblies to loosely grip the rotor. Set the assemblies aside while completing the manifold assembly.

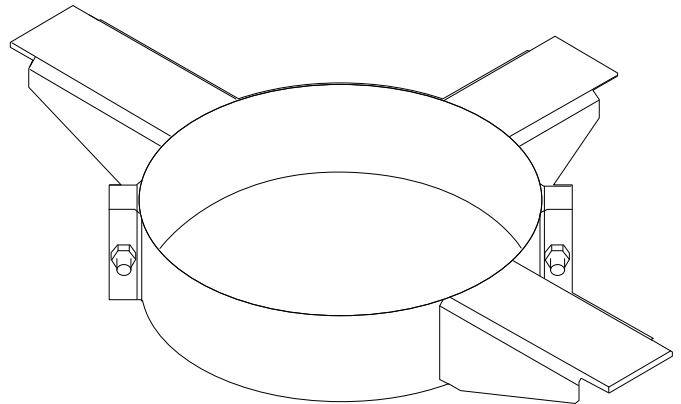

Organize and Assemble the Manifold Components

The manifold assembly components are made with 3" (80 mm) ductile iron, grooved, Victaulic type fittings. Grooved fittings are simple to assemble and disassemble if servicing is required. Each fitting is connected with a grooved coupling.

QTY	DESCRIPTION
1	Galvanized grooved x male BSP rotor adapter fitting
1	Galvanized grooved 90° elbow fitting
1	Galvanized grooved tee fitting
1	Epoxy-coated grooved butterfly valve
6	Galvanized grooved coupling
1	Galvanized grooved x 1" (25 mm) female NPT drain plate
1	Galvanized male NPT plug
1	Brass 1" female NPT ball valve (drain valve)

When assembled in conjunction with an ST-V30-KV control valve, the ST-BVF30-K fitting kit creates the manifold for the STK-6V configuration. Without the control valve, the ST-BVF30-K fitting kit creates the manifold for the STK-5V configuration. The kit also provides a point of connection for the quick coupler (not included) and/or drain valve (included).



Assemble the Grooved, Victaulic Type Fittings

ITEM	DESCRIPTION
1	Lightly lubricate the gasket with approved pipe gasket lubricant. The gasket and fittings may also be lubricated for assembly with a mild solution of dish soap and water.
2	Slide the gasket over the end of the first fitting to be connected. The gasket must not protrude or extend beyond the edge of the fitting.
3	Place the second fitting to be connected in position against the first fitting. The fittings must be held together in this position for the next step.
4	Slide the gasket over and center it between the grooves of the two fittings to be connected.
5	Press each coupling half onto the gasket and squeeze together.
6	Install bolts and nuts. Tighten evenly, alternating sides until securely tightened. Coupling halves must come together and make complete contact.
7	Nuts should face upward for ease of future service. Apply grease to subdue rust (optional).



Install the Infill Barrier System (IBS) to the Rotor

The IBS kit is required for all in-vault installations. It is necessary because the IBS outer ring is needed to create a snug fit between rotor and the vault cover. Without this outer ring, the rotor will fit too loosely within the vault, which could potentially lead to retraction issues.

For infill-type synthetic sports fields, the IBS is designed to retain the majority (but not all) of the infill material on the rotor's logo cap area as well as the area surrounding the rotor. The top of the IBS vertical barrier walls should never be exposed. These barrier walls should always be below the level of the infill material. They need to remain subsurface to promote a safe transition between the rotor's pop-up and surrounding area. Attach the two-piece IBS kit to the rotor as outlined in the instruction sheet supplied with the ST-IBS-1600 kit. Do not use adhesives to attach the IBS to the rotor, as this could inhibit or prevent future rotor servicing.

For non-infill-type synthetic sports fields, the IBS vertical walls must be trimmed to create a flat exposed upper surface area. Examples include short-pile carpet over the vault and rotor as used for field hockey, running track material over the vault and rotor, or installations where no material is placed over the vault.

Attach the Rotor and Rotor Hanger Bracket to the Manifold Assembly

Apply Teflon® tape to the manifold's outlet threads. Thread the rotor to the manifold outlet threads to provide a fully watertight seal.

For an alternative method, attach the threaded adapter to the rotor and connect the adapter to the manifold.

Configure and Position the Adjustable Support Stands

Two adjustable support stands (ST-SPT-K) are required to support the weight of the manifold. The adjustable support stands each need to be placed upon a concrete support pad (e.g., a 16" x 16" x 2" (40 cm x 40 cm x 5 cm) stepping stone.) The concrete support pads must be placed upon compacted soil. The upper surface of the concrete support pad should be approximately 39" (100 cm) from the top rim of the vault. If needed, raise or lower the concrete support pads to ensure the adjustable support stands can be adjusted to adequately support the weight of the manifold. Place one support stand under one of the couplings attached to the butterfly valve; place the other support stand under the coupling between the elbow and control valve.

Loosen the nuts on the top of the black rubber support stand base. Raise the nuts as far as possible. Press downward on the support stand's metal rail until it stops. Using pliers, spread (bend) the upper opening of the metal rail outward in the area between the two threaded shafts. This action will create a "nest" for the manifold's coupling fitting to rest upon. Place the two support stands on the concrete pads. Adjust the stands after the manifold and rotor assembly are installed in the vault.



Install and Adjust the Rotor and Manifold Assembly

Lower the rotor and manifold assembly into the vault. The three arms on the ST-BKT-1600 rotor bracket must engage the rim of the vault. Position the adjustable support stands under the manifold assembly and align them directly under the selected manifold couplings. Raise or lower the rotor within the rotor hanger bracket as necessary to achieve the correct rotor elevation relative to the adjacent vault cover. Raise or lower the adjustable support stand's metal rail to fully support the manifold.

The rotor's elevation should be adjustable as follows:

- When infill-type synthetic turf will be attached to the upper surface of the vault cover set and the top of the rotor, the upper surface (floor) of the installed IBS center cup must be the same elevation as the upper surface of the vault's cover set. Using Hunter-approved adhesive (ST-ADH-K), attach the turf material to the IBS central cup.
- When pad-type running track material or short-pile, non-infill carpet will be attached to the upper surface of the vault cover set and the top of the rotor, the vertical walls of the IBS kit must be trimmed to create a flat upper surface. Once trimmed and installed on the rotor, adjust the upper flat surface elevation to be the same elevation as the vault's upper surface. The disc of padding or carpet material to be attached to the IBS must be approximately 14 $\frac{3}{8}$ " (36 cm) in diameter. It is easier to attach this material to the IBS with the IBS central cover removed from the rotor. Using Hunter-approved adhesive (ST-ADH-K), attach the pad or carpet material to the IBS central cover. Be sure to center the IBS central cover under the pad or carpet material. The attachment of the padding or carpet material to the IBS is often the responsibility of the installing turf contractor. Always pass this information along to the installer.
- When no material is to be attached to the upper surface of the vault or the vault is to be covered with pour-in-place synthetic running track material, the vertical walls of the IBS kit should be trimmed to create a flat upper surface. Once trimmed, attach the ST-FRP-1600 simulated concrete disc to the top of the flattened IBS using Hunter-approved adhesive (ST-ADH-K). It is easier to attach this disc to the IBS with the IBS central cover removed from the rotor. Once the adhesive has dried, install the trimmed IBS central cover and disc assembly to the rotor. To set the rotor elevation, adjust the upper flat surface of the ST-FRP-1600 simulated concrete disc to be the same elevation as the vault's upper surface. If the vault and rotor are to be covered with pour-in-place synthetic running track material, it is often the responsibility of the installing turf contractor to complete this process. Always pass this information along to the installer.

Adjust the manifold assembly with the support stands so it is approximately horizontally level. Make sure the weight of the manifold is adequately supported by the two adjustable support stands. The rotor's inlet is not designed to support the manifold's weight.

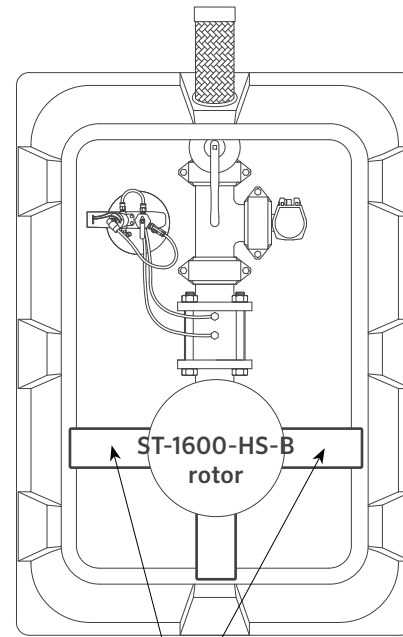

Tighten the rotor hanger bracket to lock the rotor into position.

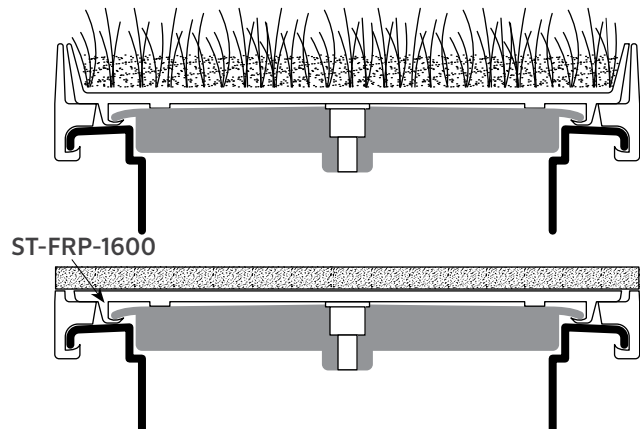
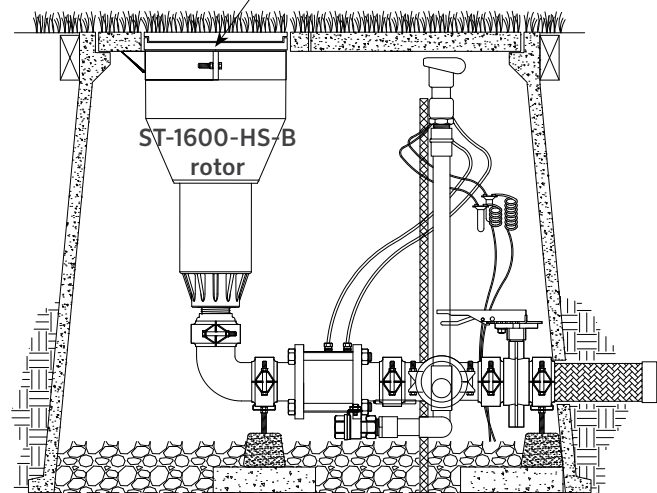

Make Final Vault Adjustments and Secure Flexible Hose Taping

After the vault, rotor, rotor hanger bracket, manifold, support stands, and flexible inlet hose are installed, make any final positioning adjustments. Make sure the flexible inlet hose is not twisted or kinked. If needed, move the vault and reset the manifold to ensure proper flexible inlet hose position and orientation. If required, loosen the grooved clamp between the flexible inlet hose and the butterfly valve to correct any twisting or kinking of the hose. Retighten the clamp when complete.

Prior to final backfilling and compacting of the soil around the vault, wrap the flexible inlet hose with plastic pipe-wrapping tape. The tape must have a minimum thickness of 10 mil (0.25 mm). Certain caustic soil conditions may require additional precautionary measures to protect the stainless steel flexible inlet hose. Consult the project specification documents for more information.

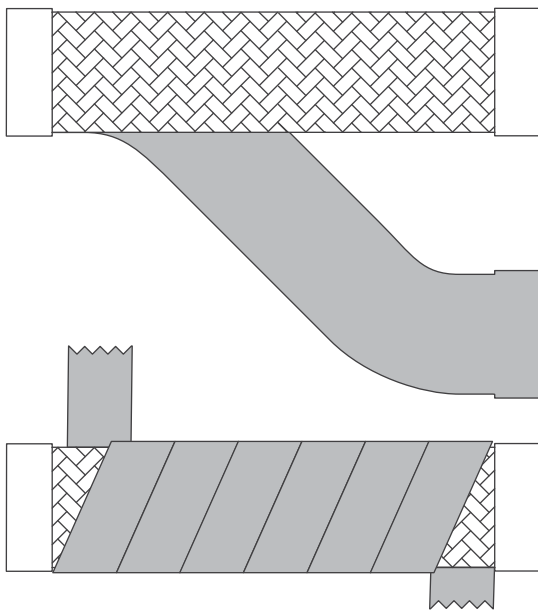

Always create smooth, kink-free, and untwisted flexible transitions.

Install the Quick Coupler Piping

Run the quick coupler supply line to the appropriate location outlined previously in this document. Connect 1" (25 mm) Schedule 80 PVC piping or metal piping per specification vertically to the quick coupler location. Next, route and install the drain valve piping and attach the brass drain valve. Make sure the drain valve is the lowest piping within the vault.

Install the Remote On-Off-Auto Selector and Solenoid Assembly

Install the remote on-off-auto selector assembly to the sidewall of the vault using the supplied hardware. Make sure the on-off-auto selector is positioned directly below the access port in the vault's cover set. Connect the solenoid using specified splice connectors.

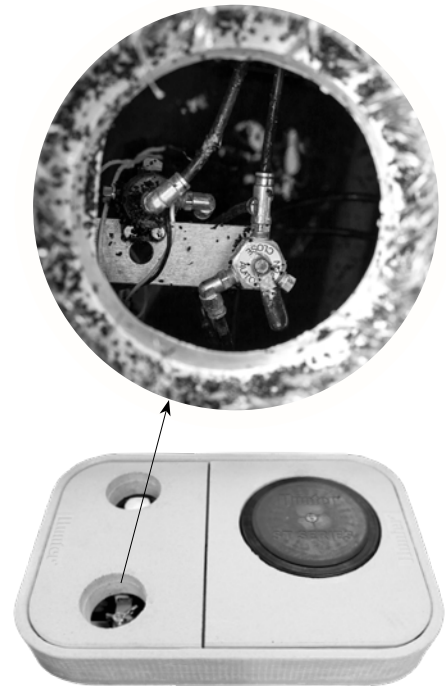

Connect the Control Tubing to the Control Valve

There are two fittings on the control valve. One fitting is on the inlet side of the valve and the other is in the center of the valve. Each fitting comes from the factory with a black protective dirt plug. To remove the plug, press downward on the collet ring at the top of the fitting while pulling the plug up and out of the fitting.

Connect the blue color-coded tubing to the control valve's center blue color-coded fitting. To do so, simply press the tube into the fitting until it stops. Pull outward to confirm the tube is locked into the fitting. To remove the tube from the fitting, press downward on the collet ring at the top of the fitting while pulling the tube up and out of the fitting. Next, connect the red color-coded tube to the red color-coded fitting on the valve.

Adjust the Arc

The rotating nozzle turret on the rotor has a ratcheting feature that allows the nozzle to be rotated to the field of play. Pull up the logo cap or activate the rotor to expose the nozzle turret and forcefully push the nozzle as needed. The nozzle turret will ratchet unless the arc adjustment clips interfere with the reversing trip arm on the back of the gear drive. If needed, slide the arc adjusting clips to move the turret. The arc adjustment clips are used to adjust the arc in a similar fashion to impact-type sprinklers. To adjust the arc, activate the rotor and adjust the arc adjustment clips to set the arc to the intended area to be irrigated. The trip arm on the back of the gear drive can be moved manually to speed the process.

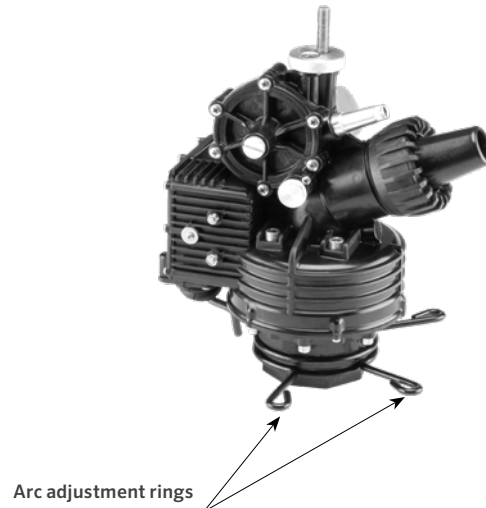

Configure the Tack/Glue Board for the Vault

In most instances, a tack/glue board is specified to be constructed around the perimeter of the ST-243636-B vault. Building the tack/glue board may or may not be the responsibility of the irrigation contractor. The purpose of the tack/glue board is to securely attach the synthetic “carpet” around the perimeter of the enclosure. Depending on the specification, the carpet will be attached with tack nails or glue (or both).

The most common tack/glue board construction material is Trex™ type 2" x 4" (5 cm x 10 cm) lumber. Depending on the field design and the location of the vault, the tack board will either be an independent perimeter board or attached to the field perimeter tack/glue board as illustrated below (ST-173026-B vault shown). The tack/glue board rests upon the compacted field base material. The design can be a close-fitting frame about the vault's exposed upper rim with adhesive between the frame and the vault, or a looser framework with concrete between the frame and vault as shown below.

The tack/glue board elevation for the vault is often equal to the tack/glue board elevation of the field perimeter. It may be equal to the elevation of the vault's perimeter rim or it may vary depending on the material (if any) that will be glued to the top of the enclosure's cover (e.g., field turf, track surface). Refer to the field and irrigation specifications to determine the appropriate elevation.

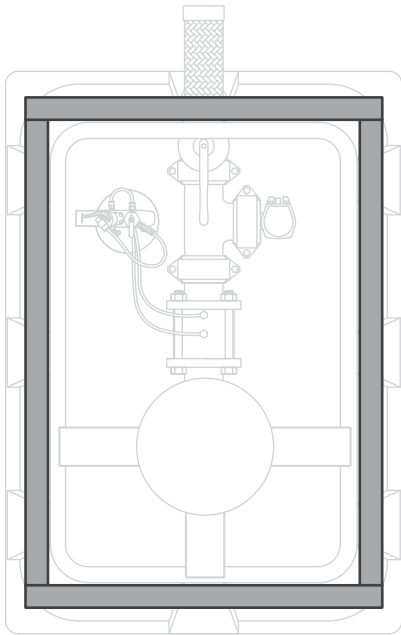



Helping our customers succeed is what drives us. While our passion for innovation and engineering is built into everything we do, it is our commitment to exceptional support that we hope will keep you in the Hunter family of customers for years to come.

A handwritten signature in black ink, appearing to read "G. R. Hunter".

Gregory R. Hunter, CEO of Hunter Industries

A handwritten signature in black ink, appearing to read "Gene Smith".

Gene Smith, President, Landscape Irrigation and Outdoor Lighting

HUNTER INDUSTRIES | *Built on Innovation*®
1940 Diamond Street, San Marcos, CA 92078 USA
hunterindustries.com

Victaulic is a trademark of Victaulic Company. Teflon is a registered trademark of the Chemours Company. Trex is a trademark of Trex Company Inc.
© 2021 Hunter Industries™. Hunter, the Hunter logo, and all other trademarks are property of Hunter Industries, registered in the U.S. and other countries.