

# ST-1600

OWNER'S MANUAL

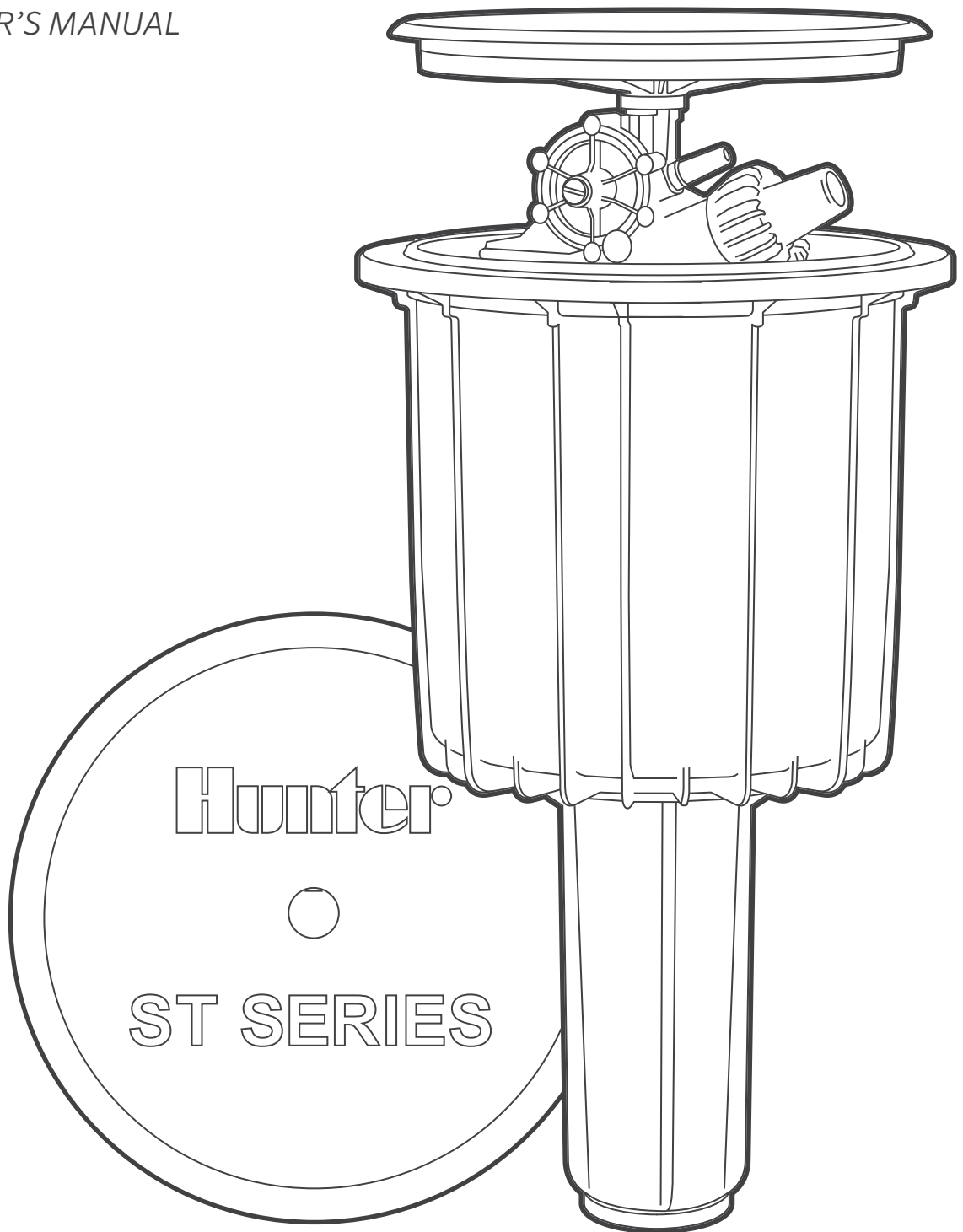

ST-1600  
Long-Range Synthetic Turf Rotor

**Hunter**<sup>®</sup>

## Overview

### ST-1600-HS-B: Pop-Up Gear Drive

The best-in-class Hunter ST-1600-HS-B gear-driven rotor offers a premium solution for synthetic turf irrigation. The rotor cools, cleans, and flushes synthetic sports fields to enhance field safety and playability. With a throwing radius up to 165' (50 m), the powerful and reliable ST-1600-HS-B rotor offers years of solid performance in a range of applications.

### ST-1600-HS-BR: Riser-Mounted Gear Drive

The riser-mounted ST-1600-HS-BR configuration is an ideal retrofit option for synthetic turf irrigation. It is also an effective dust-control solution for horse arenas, corrals, and pastures.

#### Installation

- With a maximum radius of 165' (50 m), the ST-1600 rotor is designed for placement outside the field for safety and serviceability.
- Pair the rotor with the ST-1600-KIT vault system to bring all irrigation components together inside one strong enclosure for simple access to the complete system.

#### Key Benefits

- Heavy-duty internal gear drive and stainless steel pop-up riser provide years of reliable operation
- Long-range performance flexibility up to 165' (50 m) with six nozzle choices
- Full-circle and adjustable arc in one model from 40° to 360°
- Adjustable speed of rotation using the adjustment knob to set the speed to your requirements

#### Factory Settings

- Preinstalled #20 nozzle; other nozzles are included in the packaging
- Speed control pre-set for maximum speed of rotation
- 40° arc setting

## Troubleshooting

Find other helpful information about your product, including installation tips and more.



 [hunter.direct/st1600help](https://hunter.direct/st1600help)

 +1-760-591-7383

#### Important

The water may contain foreign objects such as sand, rocks, and other impurities, which can damage the rotor. To avoid these problems, you may need to install a filter.

#### After Installation

Troubleshooting non-rotation after installation:

1. Check for plugged secondary nozzle.
2. Check for a blocked propeller in the turbine assembly.

#### Caution

- Do not perform any adjustments or controls during operation.
- Stand clear of the rotor's water jet and area of operation.
- Ensure the water jet is not directed toward persons, animals, power lines, roads, or other objects.

**Product Dimensions:**

- Overall height: 22½" (57 cm)
- Pop-up height: 5" (13 cm)
- Exposed diameter: 14" (36 cm)
- Inlet size: 2" (50 mm) BSP\*

**Operating Specifications:**

- Radius: 107' to 165' (32.5 to 50.3 m)
- Flow: 96.2 to 326.8 GPM (21.0 to 58.8 m³/hr; 350 to 980 l/min)
- Operating pressure range: 60 to 120 PSI (4.0 to 8.0 bar; 400 to 800 kPa)
- Speed of rotation: 80 seconds at 90 PSI (6.0 bar; 600 kPa) in a single 180° sweep

⚠ \*Use P/N 241400SP adapter for 2" (50 mm) PVC pipe if needed.

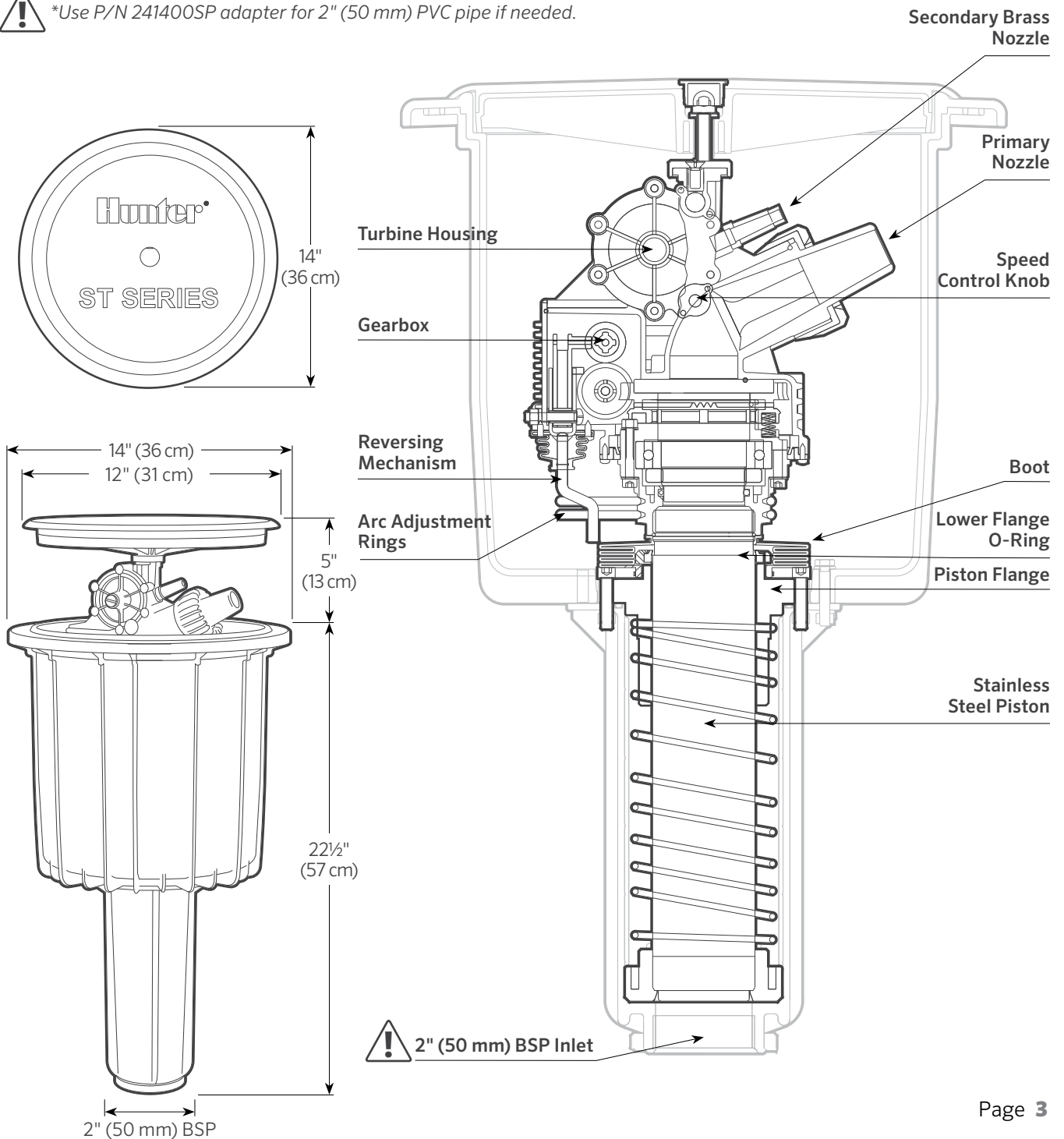

## ST-1600-HS-B: Replacement Parts

ITEM	DESCRIPTION	CATALOG NO.
1	Primary nozzle retainer	502402SP
	#16	784800SP
	#18	784801SP
2	Primary nozzle kit	
	#20	784802SP
	#22	784803SP
	#24	784804SP
	#26	784805SP
3	Secondary nozzle kit	
	Female-threaded nozzle with elbow	10005900SP
	Male-threaded nozzle	10006100SP
4	Speed control knob	510101SP
5	Gearbox cover	502455
6	Turbine assembly kit	10006200SP
7	Reversing kit	510164SP
8	Turret inlet kit	510167SP
9	Threaded rotor inlet	893600SP
10	Arc rings (2)	205617SP
11	Gear-drive assembly	881900SP
12	Rotor cover kit	204205SP
13	Upper body kit	502432SP
14	Riser assembly	502436SP
15	Rubber boot	502423
16	Lower body kit	502442SP
17	Gear-drive insertion/removal tool	517600SP

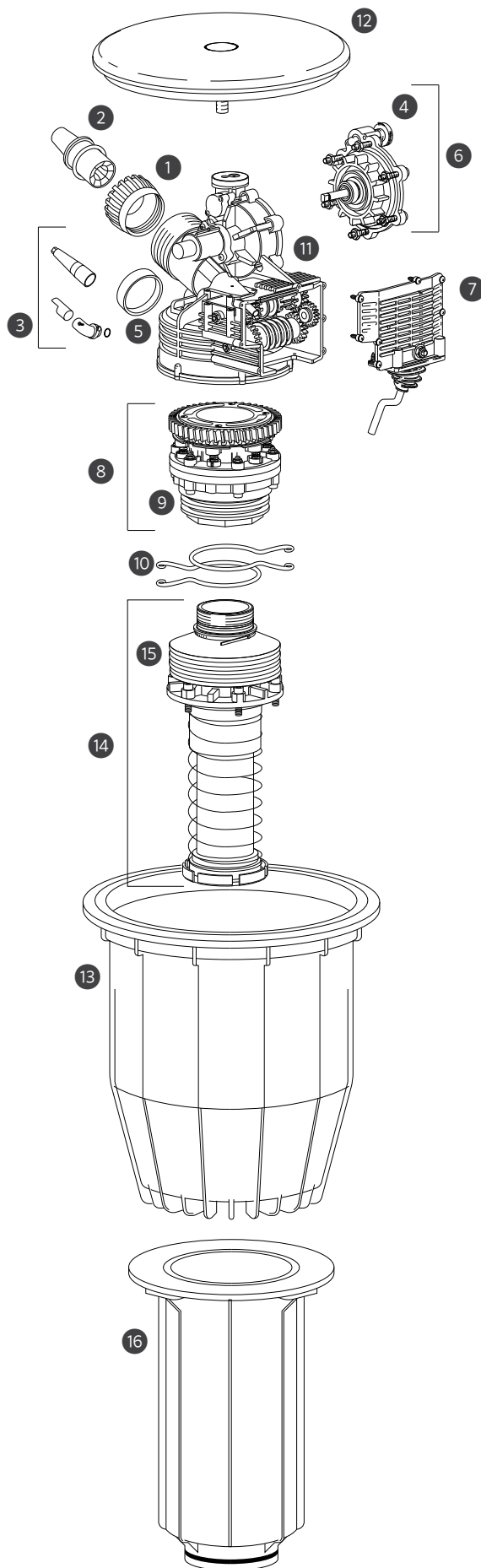

### A. Replacing the cover and rotor

1. Remove center plug with a flat-blade screwdriver and unscrew the nut underneath using a 1/2" (13 mm) socket.



2. Use the gear-drive insertion/removal tool to unscrew the rotor from the piston. The tool will grab onto the screws below the rotor.



3. Turn the wrench counterclockwise until the unit is free from the threads.
4. Lift the unit out of the body.

### B. Replacing the propeller and checking for debris

1. Remove the eight screws on the turbine housing (six large, two small).

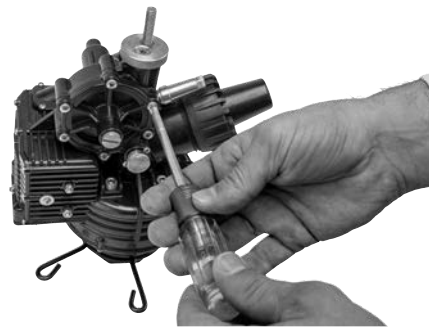

2. Pull to remove the propeller cover and expose the propeller.

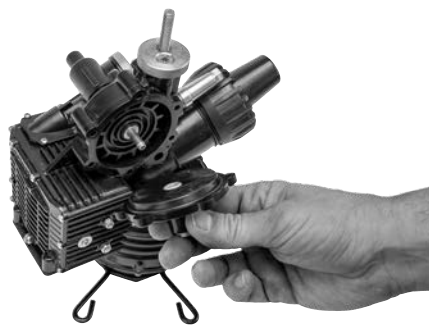

3. Remove the propeller from the housing to clear any debris that may be trapped inside.



### C. Speed control adjustment

1. Turn the brass knob clockwise to slow down rotation.

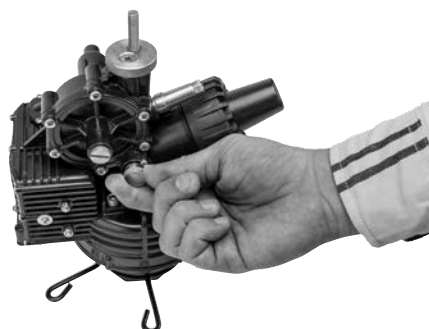

### D. Servicing secondary nozzle

1. Unthread the secondary nozzle.

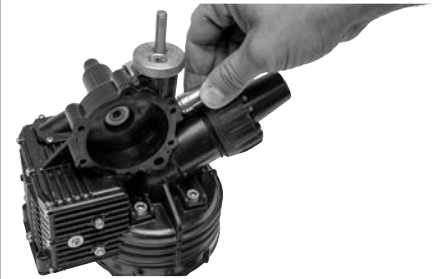

2. Clear any debris that may be trapped inside.

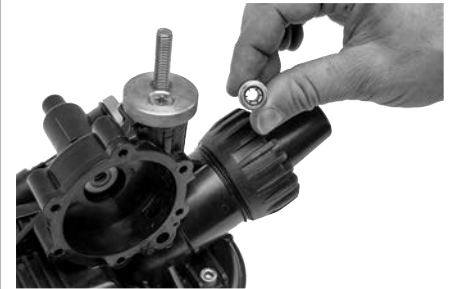

### E. Arc adjustment

1. For part-circle operation, reach inside the rotor to set the arc adjustment rings to the desired arc setting.



2. For 360° operation, remove both adjustment rings.



## ST-1600-KIT System Components

The ST-1600-HS-B rotor paired with the ST-1600-KIT vault system is the superior solution for all synthetic turf irrigation needs. The ST-1600-KIT brings ST irrigation components together inside one strong underground enclosure that offers simple access from the top for quick servicing and maintenance.

ITEM	DESCRIPTION
1	<b>ST-1600-HS-B</b> Synthetic turf rotor
2	<b>ST-IBS-1600</b> Rubber cover kit with infill barrier system
3	<b>ST-243636-B</b> Vault
4	<b>ST-BKT-1600</b> Bracket for rotor
5	<b>ST-BVF30-K</b> Manifold, including 3" (80 mm) Victaulic® fittings, isolation valve, drain valve
6	<b>ST-V30-KV</b> 3" (80 mm) grooved Victaulic type low-pressure-loss valve
7	<b>ST-SPT-K</b> Adjustable manifold supports (2 required)
8	<b>ST-H30-K</b> Flexible stainless steel hose, Victaulic connection to 3" (80 mm) female NPT
9	<b>HQ-5RC</b> Quick coupler 1" (25 mm) inlet with 1¼" (30 mm) outlet
10	On-off-auto selector (included with ST-V30-KV)
11	Compacted ground base

**Note:** All components above make up the ST-1600-KIT.

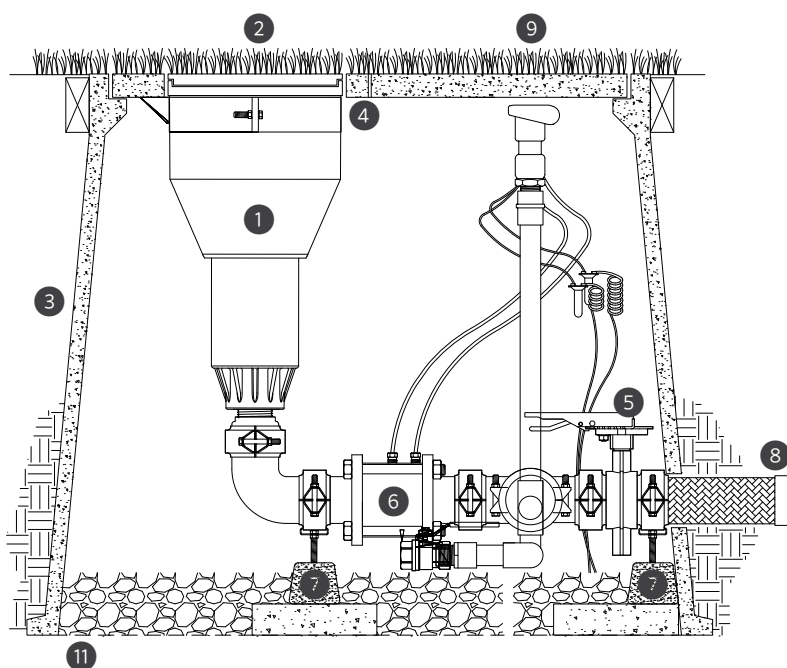
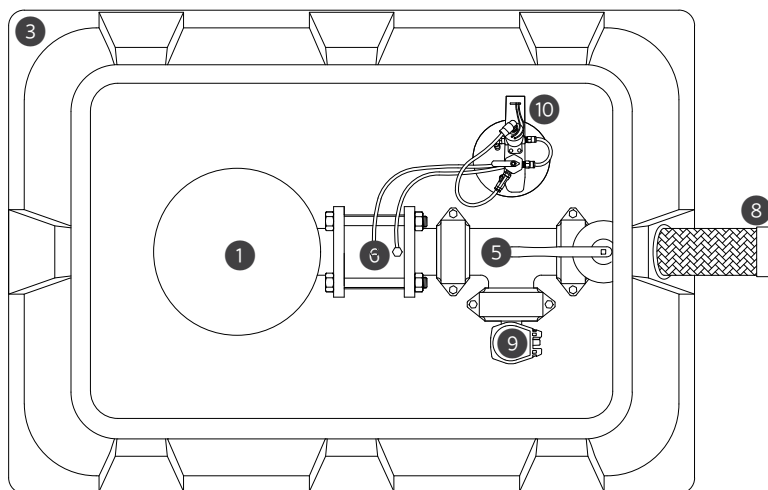

## Riser-Mounted System Components

The riser-mounted ST-1600-HS-BR cools and cleans synthetic fields from above. If riser-mounted irrigation is your choice, protect the riser with padding for safety. This option is also a great dust-control solution for horse arenas, corrals, and pastures.

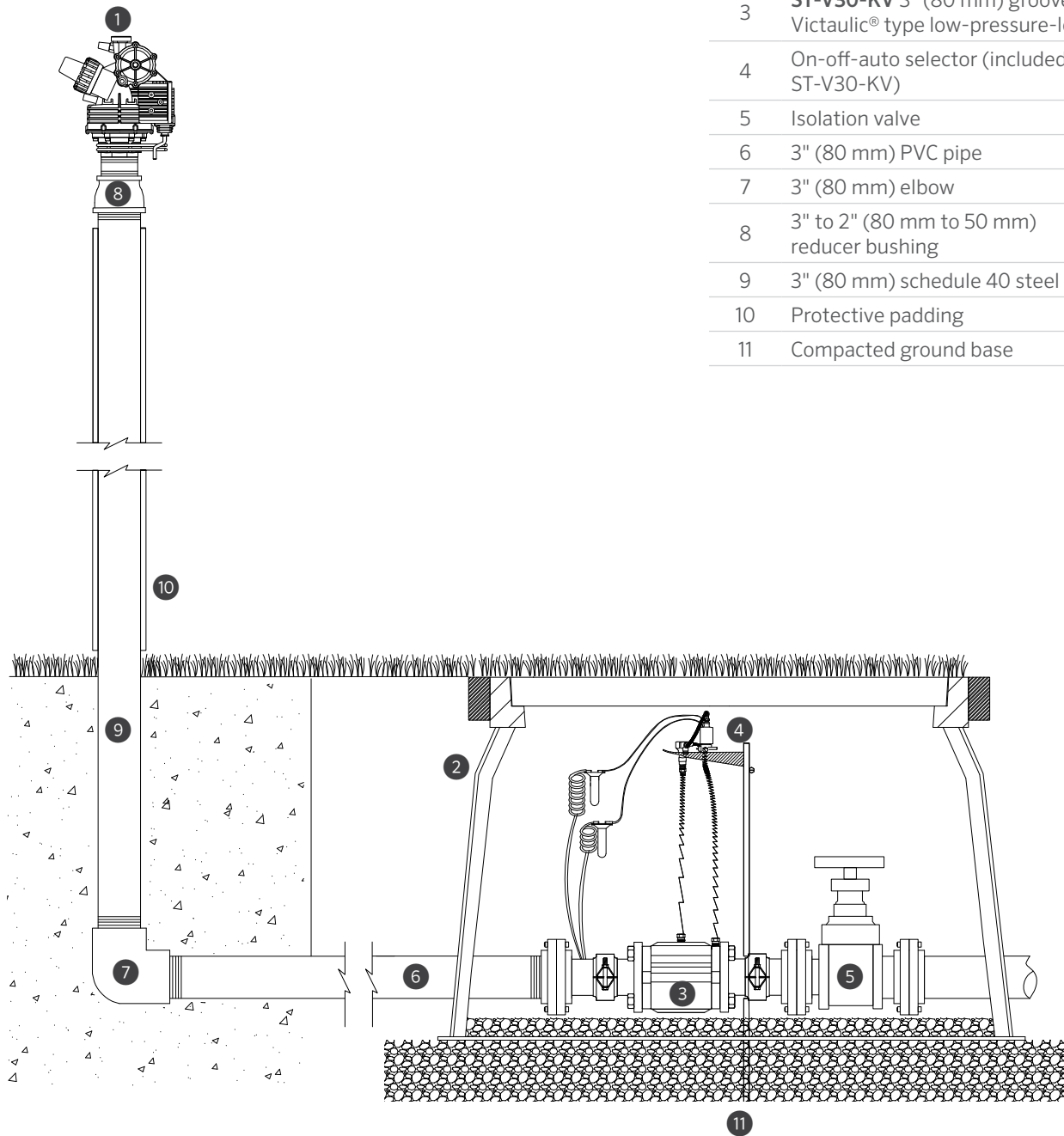

ITEM	DESCRIPTION
1	ST-1600-HS-BR Riser mount synthetic turf rotor
2	ST-173026-C Vault
3	ST-V30-KV 3" (80 mm) grooved Victaulic® type low-pressure-loss valve
4	On-off-auto selector (included with ST-V30-KV)
5	Isolation valve
6	3" (80 mm) PVC pipe
7	3" (80 mm) elbow
8	3" to 2" (80 mm to 50 mm) reducer bushing
9	3" (80 mm) schedule 40 steel pipe
10	Protective padding
11	Compacted ground base

## Field Layouts

American football field, with a #20 nozzle installed, operating at 100 PSI (7.0 bar; 700 kPa)

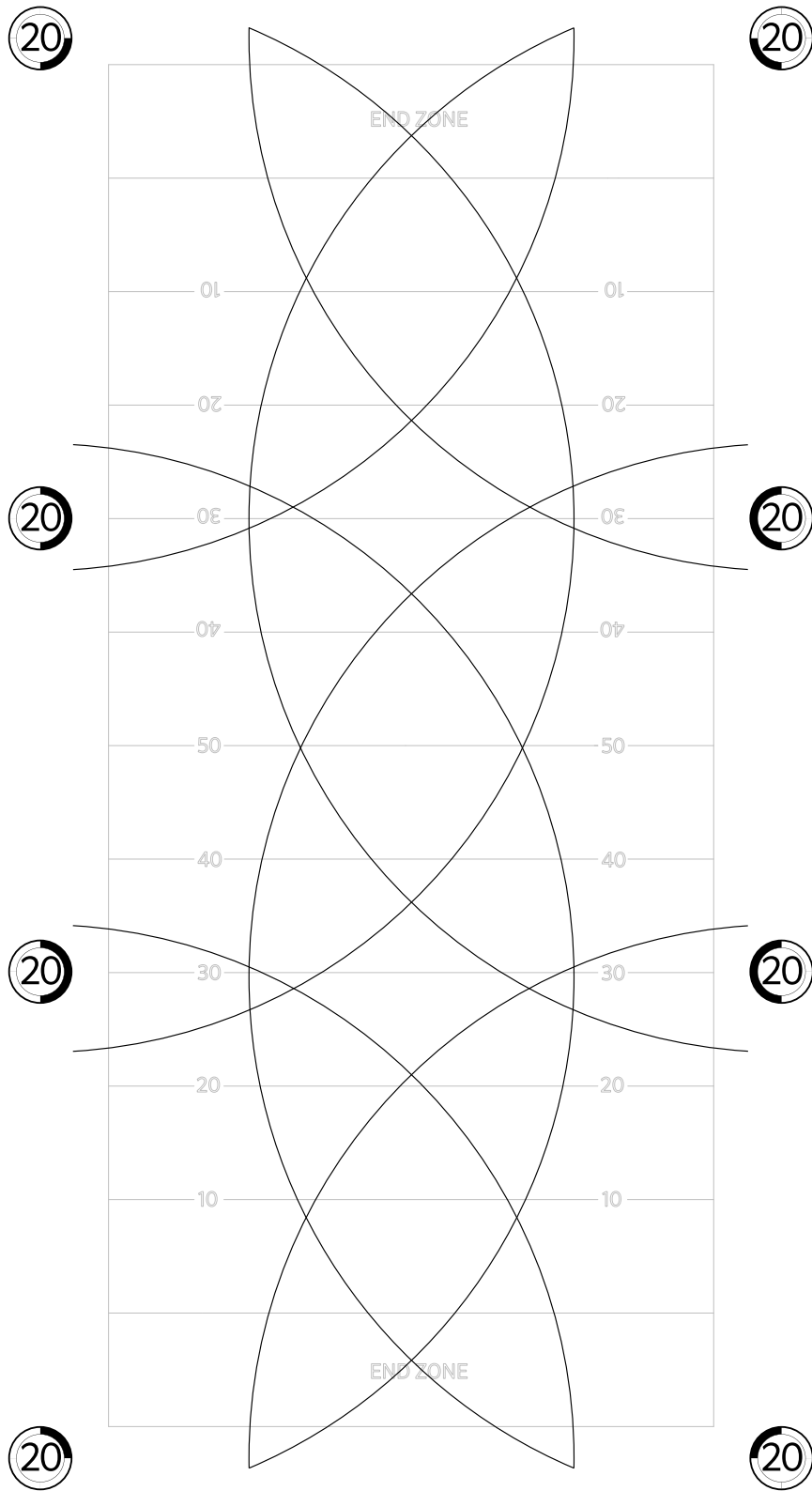



International soccer pitch, with a #24 nozzle installed, operating at 90 PSI (6.0 bar; 600 kPa)

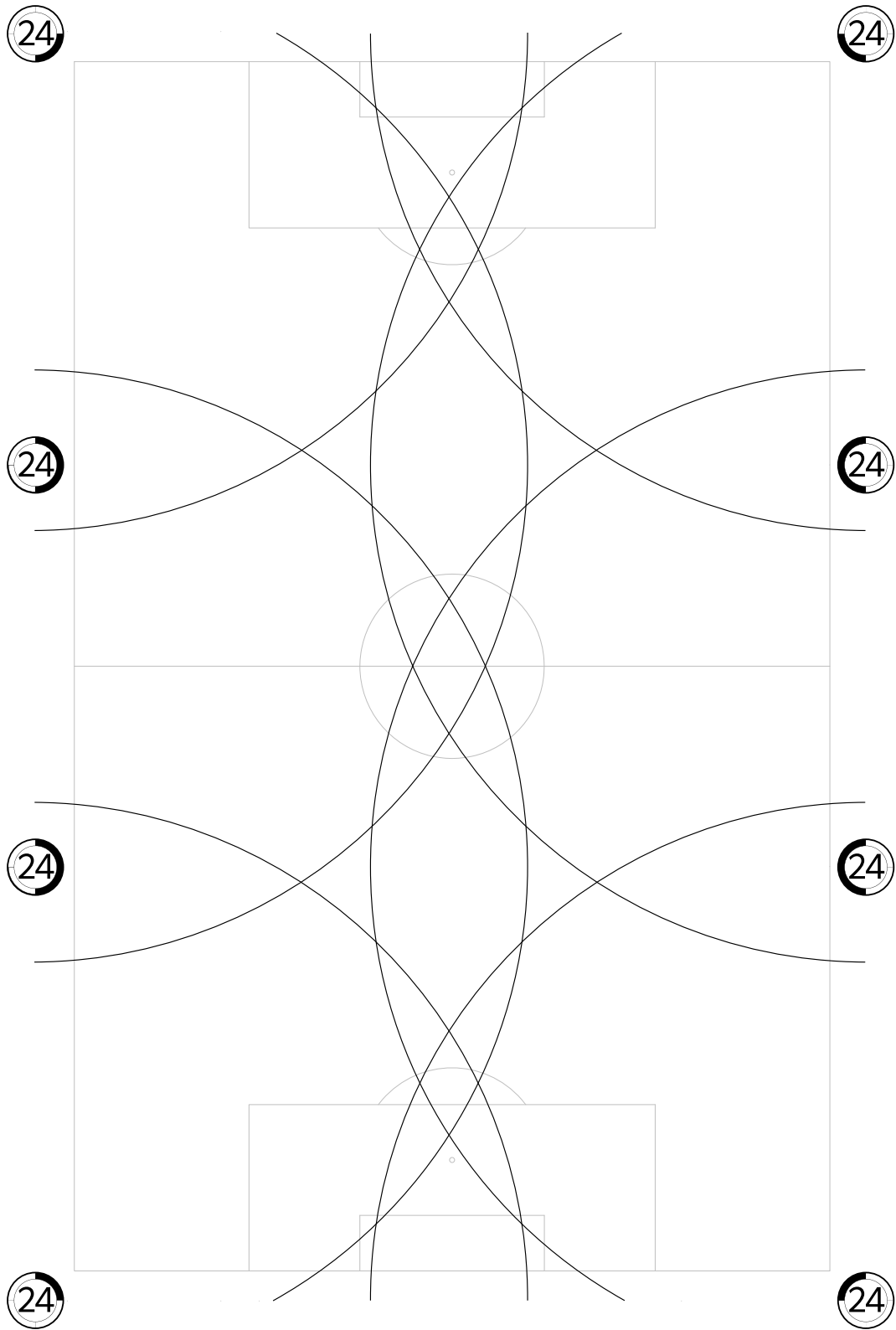

**ST-1600 PERFORMANCE DATA (IMPERIAL)**

Nozzle	Pressure	Radius ft.	Flow GPM	Precipitation in/hr*	
	PSI			■	▲
<b>16</b>	60	107	96.2	1.63	1.88
	70	115	107.3	1.57	1.81
	90	121	117.8	1.54	1.78
	100	128	127.3	1.50	1.73
	115	135	137.4	1.46	1.69
<b>18</b>	60	112	107.0	1.66	1.91
	70	121	119.4	1.56	1.80
	90	128	131.0	1.54	1.78
	100	133	141.3	1.54	1.78
	115	141	153.2	1.48	1.71
<b>20</b> (Factory installed)	60	115	144.0	2.10	2.43
	70	128	160.9	1.89	2.18
	90	141	176.5	1.71	1.97
	100	144	190.5	1.76	2.03
	115	148	204.2	1.80	2.08
<b>22</b>	60	118	171.5	2.37	2.73
	70	130	191.8	2.20	2.54
	90	144	210.0	1.94	2.24
	100	151	226.9	1.84	2.12
	115	157	243.1	1.89	2.18
<b>24</b>	60	121	202.1	2.64	3.05
	70	133	225.9	2.46	2.84
	90	148	247.6	2.19	2.52
	100	156	267.4	2.12	2.45
	115	160	286.4	2.16	2.49
<b>26</b>	60	126	233.2	2.83	3.27
	70	136	260.4	2.71	3.13
	90	151	284.5	2.40	2.77
	100	160	307.0	2.31	2.67
	115	165	326.8	2.32	2.68

\* All precipitation rates calculated for 180° operation. For the precipitation rate of a 360° sprinkler, divide by 2.

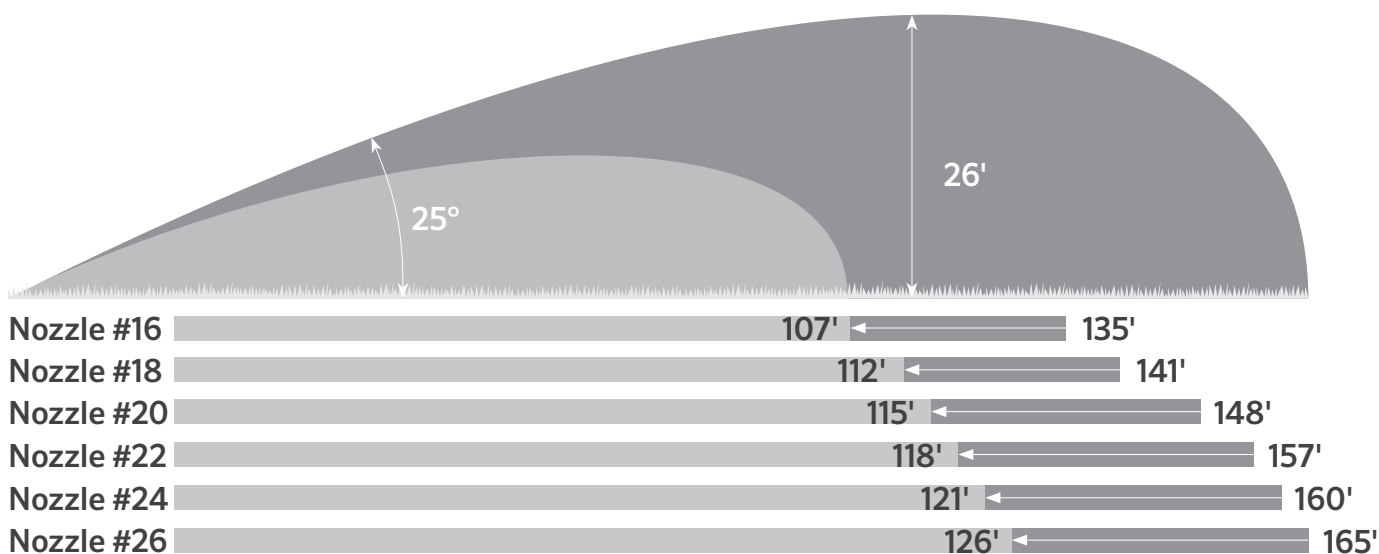

**ST-1600 PERFORMANCE DATA (METRIC)**

Nozzle	Pressure		Radius m	Flow		Precipitation mm/hr*	
	Bar	kPa		m <sup>3</sup> /hr	l/min	■	▲
<b>16</b>	4.0	400	32.5	21.8	364	41.4	47.8
	5.0	500	35.0	24.4	406	39.8	45.9
	6.0	600	37.0	26.8	446	39.1	45.1
	7.0	700	39.0	28.9	482	38.0	43.9
	8.0	800	41.0	31.2	520	37.1	42.9
<b>18</b>	4.0	400	34.0	24.3	405	42.0	48.6
	5.0	500	37.0	27.1	452	39.6	45.8
	6.0	600	39.0	29.8	496	39.1	45.2
	7.0	700	40.5	32.1	535	39.1	45.2
	8.0	800	43.0	34.8	580	37.6	43.5
<b>20</b> (Factory installed)	4.0	400	35.0	32.7	545	53.4	61.7
	5.0	500	39.0	36.5	609	48.1	55.5
	6.0	600	43.0	40.1	668	43.4	50.1
	7.0	700	44.0	43.3	721	44.7	51.6
	8.0	800	45.0	46.4	773	45.8	52.9
<b>22</b>	4.0	400	36.0	38.9	649	60.1	69.4
	5.0	500	39.5	43.6	726	55.8	64.5
	6.0	600	44.0	47.7	795	49.3	56.9
	7.0	700	47.0	51.5	859	46.7	53.9
	8.0	800	48.0	55.2	920	47.9	55.3
<b>24</b>	4.0	400	37.0	45.9	765	67.1	77.4
	5.0	500	40.5	51.3	855	62.6	72.2
	6.0	600	45.0	56.2	937	55.5	64.1
	7.0	700	47.5	60.7	1012	53.8	62.2
	8.0	800	48.7	65.0	1084	54.9	63.3
<b>26</b>	4.0	400	38.4	53.0	883	71.8	82.9
	5.0	500	41.4	59.2	986	68.8	79.5
	6.0	600	46.0	64.6	1077	61.0	70.4
	7.0	700	48.7	69.7	1162	58.6	67.7
	8.0	800	50.3	74.2	1237	58.7	67.8

\* All precipitation rates calculated for 180° operation. For the precipitation rate of a 360° sprinkler, divide by 2.

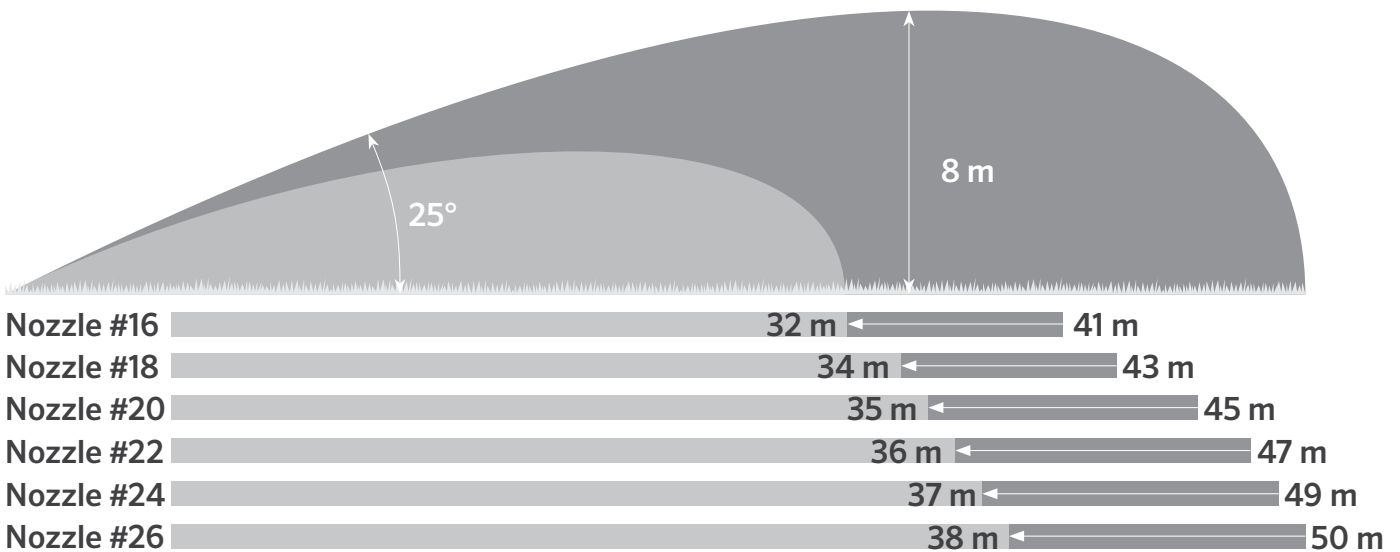



Helping our customers succeed is what drives us. While our passion for innovation and engineering is built into everything we do, it is our commitment to exceptional support that we hope will keep you in the Hunter family of customers for years to come.

A handwritten signature in black ink, appearing to read "G.R. Hunter", with a long horizontal flourish extending to the right.

Gregory R. Hunter, CEO of Hunter Industries

A handwritten signature in black ink, appearing to read "Gene Smith", with a long horizontal flourish extending to the right.

Gene Smith, President, Landscape Irrigation and Outdoor Lighting

---

**HUNTER INDUSTRIES INCORPORATED** | *Built on Innovation*®  
1940 Diamond Street, San Marcos, California 92078 USA  
hunterindustries.com

© 2021 Hunter Industries Inc. Hunter, the Hunter logo, and all other trademarks are property of Hunter Industries, registered in the U.S. and other countries.